

PAIN GENERATED BY OBSERVATION OF OTHERS IN PAIN

BY

JODY OSBORN

A thesis submitted to
The University of Birmingham
For the degree of
DOCTOR OF PHILOSOPHY

School of Psychology
University of Birmingham
May 2011

UNIVERSITY OF
BIRMINGHAM

University of Birmingham Research Archive

e-theses repository

This unpublished thesis/dissertation is copyright of the author and/or third parties. The intellectual property rights of the author or third parties in respect of this work are as defined by The Copyright Designs and Patents Act 1988 or as modified by any successor legislation.

Any use made of information contained in this thesis/dissertation must be in accordance with that legislation and must be properly acknowledged. Further distribution or reproduction in any format is prohibited without the permission of the copyright holder.

Acknowledgements

Special thanks to Mr Grenville Green for funding the project and giving me this opportunity.

Thank you so much to Dr. Stuart Derbyshire for giving me a chance as well as the support and guidance throughout my PhD.

A million thanks to some great friends who helped me so much during my PhD; Alex, Fran, Nina, Christine, Noreen, Emma, Ben and Helen.

Nicola, you have been the greatest. I don't know what I would have done without you!

Abstract

Recently, observation of pain has been linked to areas of the brain coding the sensory/discriminative aspects of pain (Avenanti et al., 2005; Avenanti et al., 2006). The experiential qualities associated with observing another in pain are poorly understood. In this thesis, we demonstrate that pain generated by observation of others in pain is reported by a significant minority of healthy individuals. The pain reported is mild, transient and occurs in the same location as the observed pain. Ten pain responders were matched with ten non-responders to take part in an fMRI study observing others in pain. Responders activated emotional and sensory brain regions associated with pain while the non-responders activated very little. Reports of pain were more likely to be accompanied by a pain memory. Pain responders are quicker to represent the perspective of others and have a more flexible sense of body ownership but are not more likely to report somatic symptoms during incongruent sensori-motor feedback. These findings provide convincing evidence that some people can readily experience pain during observation of others' pain. It is plausible that the mechanism underpinning pain reports evoked by observation of pain is not specific to pain processing per se.

CONTENTS

CHAPTER ONE: INTRODUCTION	1
1.1 Introduction	2
1.2 Models of Pain.....	3
1.2.1 Specificity Theory.....	3
1.3 Brain regions implicated in affect and sensory aspects pain	6
1.4 Functional Pain	7
1.4.1 Prevalence of functional pain.....	7
1.4.2 The problem of functional pain.....	8
1.4.3 Functional Pain and mental health.....	9
1.5 Bridging the gap between psychological and physical pain.....	10
1.6 Generating pain sensation without external noxious stimuli.....	11
1.6.1 Sensori—motor conflict.....	11
1.7. Acute Pain Symptoms with no obvious cause.....	15
1.7.1 Mass Psychogenic Illness	15
1.8 Shared somatic experiences.....	17
1.8.1 The development of somatic symptoms	17
1.8.2 Affect and symptom reporting	18
1.9 Response expectancy and pain without injury	19
1.10 Affect and observation of others in pain	20
1.10.1 Embodied simulation	20
1.11 Sensations and observing other in pain	21
1.12 Touch Synaesthesia	22
1.12.1 Synaesthesia and Pain.....	23
1.13 Case studies of pain in the absence of injury	25
1.13.1 Pain Flashbacks.....	25
1.13.2 Watching another in pain generates pain sensation	26
1.14 Thesis Summary	26
CHAPTER TWO: PAIN SENSATION GENERATED BY OBSERVATION OF OTHERS IN PAIN.....	28
2.1 Introduction	28
2.2 Method.....	30
2.2.1 Participants.....	30
2.2.3 Procedure	34
2.2.3.1 Visual Analogue Scales.....	34

2.2.3.3 The short version of the McGill Pain Questionnaire (Melzack, 1987).....	35
2.3 Results	35
2.3.1 Pain Reports	35
2.3.2 Somatisation.....	37
2.4 Discussion.....	38
2.5 Experiment Two	43
2.6 Introduction	43
2.6.1 Pain Judgements	43
2.6.2 Memory for painful events and observation of pain.....	45
2.7 Method.....	46
2.7.1 Design	46
2.7.2 Participants.....	46
2.7.3 Procedure	47
2.8 Results	47
2.8.1 Pain Judgments	48
2.8.2 Response Expectancy.....	50
2.8.3 Pain Memories	50
2.9 Discussion.....	51
2.9.1 Empathy and Pain Judgements	52
2.9.2 Memory and Pain.....	53
2.9.3 Response Expectancy.....	54
2.10 Experiment Three	55
2.11 Introduction	55
2.12 Method.....	57
2.12.1 Participants.....	57
2.12.2 Procedure and scale	57
2.12.2.1 Cardiff Anomalous Perceptions Scale (CAPS).....	57
2.13 Results	58
2.13.1 Overall CAPS score	58
2.13 Discussion.....	61
CHAPTER THREE: NEURAL CORRELATES OF PAIN SENSATIONS GENERATED BY OBSERVATION OF OTHERS PAIN	64
3.1 Introduction	64
3.2 Method.....	65
3.2.1 Participants.....	65
3.2.2 Visual stimuli.....	65
3.2.3 fMRI procedure.....	66
3.2.4 Data Analysis	67
3.3 Results	68
3.3.1 Behavioural Data	68
3.3.2 fMRI Experiment.....	69
3.4 Discussion.....	73

CHAPTER FOUR: OVERT MOTOR RESPONSES NOT MODULATED BY PAIN GENERATED VIA OBSERVATION OF ANOTHER IN PAIN	78
4.1 Introduction	78
4.2 Method.....	82
4.2.1 Experiment One	82
4.2.1.2 Design.....	82
4.2.1.1 Participants	82
4.2.1.2 Procedure.....	82
4.2.2 Experiment Two	84
4.2.2.1 Design.....	84
4.2.2.1 Participants	84
4.2.2.2 Procedure.....	85
4.3 Results	85
4.3.1 Experiment One	85
4.3.2 Experiment Two	85
4.4 Discussion.....	86
CHAPTER FIVE: THE ROLE OF VISUAL PERSPECTIVE TAKING IN PAIN WITHOUT INJURY	97
5.1 Introduction	97
5.1.1 Visual Perspective Taking	97
5.1.2 Embodiment and Spatial Perspective Taking	99
5.2 Method.....	101
5.2.2 Participants.....	101
5.2.3 Visual Perspective taking task	101
5.2.3.1 Design.....	101
5.2.3.2 Procedure.....	101
5.2.4 Spatial perspective taking task	103
5.2.4.1 Design.....	103
5.3.4.2 Procedure.....	103
5.3 Results	104
5.3.1 Visual Perspective Taking Task	104
5.3.2 Spatial Perspective Taking task	104
5.3.2.1 Lateralization Task (Baseline condition)	104
5.3.3.2 Spatial Transformation Task (Main task).....	104
5.4. Discussion.....	104
CHAPTER SIX: ASYNCHRONOUS STROKING DOES NOT DIMINISH SENSE OF OWNERSHIP DURING RUBBER HAND ILLUSION.	111
6.1 Introduction	111
6.1.1 Rubber Hand Illusion.....	112
6.1.2 Predefined body map	112
6.1.3. Intermodal matching between vision and touch	113
6.1.4 Individual Differences during the RHI	114

6.1.5 RHI and movement	114
6.2 Method.....	116
6.2.1. Experimental Design.....	116
6.2.2 Participants.....	116
6.2.3 Procedure	116
6.2.3.1 Botvinick and Cohen Questionnaire	119
6.2.3.2 McCabe Questionnaire.....	120
6.3 Results	120
6.3.1 Overall RHI illusion results	120
6.3.2 Asynchronous versus synchronous stroking.....	120
6.3.3 Location of Sensation during asynchronous stroking.....	120
6.3.4. Ownership during stroking conditions.....	121
6.3.5 Location during tapping.....	123
6.3.6 Ownership during tapping	123
6.3.7 Somatic changes during stroking conditions	124
6.3.8 Somatic changes during synchronous and asynchronous stroking.....	125
6.3.9 Somatic changes during synchronous and asynchronous tapping	125
6.4 Discussion.....	120
6.4.1 Asynchronous stroking does not diminish rubber hand illusion.....	128
6.4.2 Pain and sensori-motor conflict	132
6.4.3 Somatic reports during sensory-motor conflict	132
6.4.4 Somatic symptoms during stroking conditions.....	133
CHAPTER SEVEN: GENERAL DISCUSSION.....	135
7.1 Overview	135
7.2 Aims of the thesis	135
7.3 Neural correlates of pain generated by observation of pain in others	136
7.4 Visual Representations of pain	141
7.5 Pain in perspective.....	142
7.7 Domain specific pain observation	145
7.8 Strengths and Limitations.....	147
7.9 Conclusions and future directions	148

List of Figures

Figure 1.1: Melzack and Wall's gate control theory of pain.....	4
Figure 1.2: A model of factors involved in functional somatic syndromes reproduced from.....	8
Figure 1.3: The role of the efference copy on the motor control system.	11
Figure 1.4: shows the procedure used in McCabe et al (2005). On the left is a participant carrying out congruent movement and, on the right, the same participant carrying out incongruent feedback.	12
Figure 2.1: shows the images used to elicit pain for the behavioural study.....	28
Figure 2.2: Mean ratings for disgust, fear, sadness, unpleasantness and state empathy for subjects who responded with pain (pain responders) to at least one of the images or clips in comparison to mean ratings for subjects who did not report any pain (non pain responders).	33
Figure 2.4: Pain responders and emotional responders reported higher ratings compared with non responders on all measures except pain judgements. Asterisks indicate significant differences (* $p < 0.05$, ** $p < 0.001$) and error bars show standard errors.	34
Figure 2.5: shows that the number of pain memories reported by pain responders is higher than both control groups.....	49
Figure 2.6: reproduced from Bell et al., 2006 showing distribution of CAPS scores in a both a control and clinical sample.....	55
Figure 2.7: shows the mean score for anomalous experiences reported (max score 32), how distracting participants found the anomalous experiences (max score 180), how disturbing participants found the anomalous experiences (max score 180) and how frequently they occurred (max score 180). Standardized CAPS refers to results generated from a sample of 337 healthy controls used to validate the CAPS scale reported in Bell et al., (2006). Bottom graph shows the mean score for how distracted and disturbed pain responders felt during the 3 most common anomalous experiences	59
Figure 3.1: shows part of a functional run with the 4 image conditions illustrated from left to right: pain image, scrambled pain image, emotional image and neutral image.....	65
Figure 3.2: Top left (A) illustrates a typical pain image shown to all subjects during fMRI. This image generated pain and emotion in the responders but only emotion in the non-responders. A typical non-pain emotion picture is shown to the right and pain picture to the left. Subtracting the brain activation during the non-pain emotion images from brain activation during the pain images reveals regions of the pain neuromatrix (labeled) in the responders but not in the non-responders. These differences between the groups are shown below (B) thresholded at $p < 0.01$ (uncorrected) to show the profile of difference. Whole brain analysis demonstrated significantly ($p < 0.05$, corrected) greater activation in the responders versus the non-responders in the left prefrontal cortex (MNI coordinates: -4, 52, 32; Z(height)=5.2; k(extent)=698). The results of the ROI analysis are graphed at the bottom (C). Asterisks indicate significant	

differences ($p < 0.05$) and error bars show standard errors.....	69
Figure 4.1: shows the experimental procedure for experiment 1 and the three different types of stimuli. Right to left: 1) Hand presented without any stimuli 2) Touch stimuli (needle covered with a plastic top, touching the index finger 3) Painful stimuli (needle appearing as if it is piercing the index finger). Participants were instructed to press or release the space bar when viewing the image.....	81
Figure 4.2: shows the experimental procedure for experiment 1 and the three different types of stimuli. Right to left: 1) Hand presented without any stimuli 2) Touch stimuli (needle covered with a plastic top, touching the index finger 3) Painful stimuli (needle appearing as if it is piercing the index finger). Participants were instructed to press or release the space bar when viewing the image.....	83
Figure 4.3: reaction times for key presses and releases as a function of group.	86
Figure 4.4: shows reaction times for both groups in response to each image collapsed across response.....	87
Figure 4.5: shows reaction times after viewing each image type as a function of key press (Press/Release).	88
Figure 4.6: shows the mean reaction times for each image either presented for 500ms or 1000ms for presses and releases.	89
Figure 5.1: Top image shows avatar observing two dots, this viewpoint is consistent with the participant's viewpoint. Bottom image shows avatar observing 1 dot, the avatars perspective is inconsistent with participant's viewpoint.....	96
Figure 5.2: depicts the stimuli used in the main experiment adapted from Blanke et al., (2005). Participants are required to state which hand the glove is on. A and C are in spatially aligned with participants, therefore no spatial transformation is necessary. B and D require the participant to mentally rotate their body in order to correctly identify which the location of the glove. Underneath each figure are the correct responses.	97
Figure 5.3: illustrates that participants took longer to respond during inconsistent trials ($F(1, 24) = 5.3, p = 0.03$). Participants were faster to verify another's perspective during consistent trials relative to inconsistent trials ($F(1, 24) = 49.3, p < 0.001$).....	99
Figure 5.4: shows that pain responders responded more quickly during consistent trials versus inconsistent trials ($F(1, 9) = 31.1, p < 0.001$). Patterns of responses were similar when adopting self perspective versus other during consistent and inconsistent trials. There was no significant interaction between consistency and perspective ($F(1, 9) = 2.08, p = 0.18$).....	100
Figure 5.5: shows reaction times for non pain responders were faster during consistent trials versus inconsistent trials ($F(1, 15) = 11.7, p < 0.004$). Non responders were faster to verifying the avatars perspective during consistent trials compared with inconsistent trials, however there was little differences during consistent and inconsistent trials when verifying self perspective. The interaction between consistency and perspective was significant for non pain responders.....	101
Figure 6.1: shows the appearance of the wooden blocks ranging from 1-4 with 4 as most similar in appearance to a human hand, and 5, a prosthetic hand.....	105
Figure 6.2: The role of the efference copy on the motor control system.....	111

Figure 6.3: illustrates the experimental set up. P1 sat in chair with right hand occluded by the screen. P2's hand was positioned in place of P1's right hand. P1 was instructed to fixate on P2's hand during all conditions.	115
Figure 6.4: illustrates 3 items of the Botvinick and Cohen (1998) questionnaire used to assess the degree of ownership of another hand. Participants were asked to indicate the extent to which they agreed or disagreed with each statement. The items adapted for use with the motor or tapping version of the rubber hand experiment.	117
Figure 6.5: A) illustrates the group mean ratings for the extent to which participants feel touch sensations at the location of other participants hand during synchronous and asynchronous stroking. B) illustrates the group mean ratings for feelings of ownership over the other participants hand during synchronous and asynchronous stroking. Error bars represent standard errors.	115
Figure 6.6: A) illustrates the group mean ratings for the extent to which participants feel touch sensations at the location of other participants hand during synchronous and asynchronous tapping. B) illustrates the group mean ratings for feelings of ownership over the other participants hand during synchronous and asynchronous tapping. Error bars represent standard errors.	123

List of Tables

Table 2.1: total count and percentage of pain responders who reported pain and painful memories (left), total count and percentage of pain responders who reported a painful memory and also reported pain.	49
Table 2.2: shows the range of responses on all four measures on CAPS for pain responders and non pain responders. Brackets show the average range reported by a sample of 337 healthy controls reported in Bell et al. (2006).	58
Table 2.3: shows the correlation between the frequency of pain reports and total number of CAPS anomalous experiences.	60
Table 3.1: Disgust, pain intensity, unpleasantness and state empathy scores for pain responders and non-responders recorded during the behavioural experiment. All ratings were from 0 (nothing experienced) to 10 (maximum pain intensity, unpleasantness or state empathy). Non-responders were selected for their lack of pain experience during observation and no pain was reported by any of the non-responders to any of the images or clips.	67
Table 3.2: Group differences for the regions with increasing BOLD response when comparing pain images with emotion images.	67
Table 6.2: Frequency of each somatic sensations in all 4 conditions presented by group (SS: synchronous stroking, SA: asynchronous stroking, MS: synchronous movement/tapping, MA: asynchronous movement/tapping)	126

CHAPTER ONE: INTRODUCTION

1.1 Introduction

The most commonly accepted definition of pain is provided by the International Association for the Study of Pain (IASP) (described by Merskey, 1991). The IASP definition states that pain is “an unpleasant sensory and emotional experience associated with actual or potential tissue damage, or described in terms of such damage... Pain is always subjective.”

The above definition of pain outlines that pain is subjective and is associated with actual or potential tissue damage. Most theories take account of the physiological changes linked to tissue damage, accounting for “pain is always subjective”. Subjectivity of experience has always presented a problem for theories of pain. Subjectivity of experience refers to the way individuals perceive stimuli and events. For example, some people report a painful stimulus as intolerable and others as mildly unpleasant. Inter individual variability of pain has been associated with different patterns of brain activity. Coghill, McHaffie and Yen (2003) demonstrated that participants who reported more pain in response to noxious stimuli showed greater activity in the areas of the brain linked to the unpleasant aspects of pain. The subjectivity or psychological experience of pain is often used as a vague explanation for pain without accompanying pathology. Often in the absence of pathology, pain is referred to a psychogenic, psychosomatic, or just “all in the head”. Psychosomatic accounts of pain focus on the role of psychological factors that prolong and exacerbate acute pain caused by noxious input and fail to offer a mechanism

that accounts for pain entirely in the absence of injury. Perceiving painful stimuli is somewhat dependent on patterns of learning, mainly through interaction with others. Previous exposure to painful events likely shapes the way we respond to future painful events and pain in others. Representations of pain are activated during observation of others in pain (Singer et al., 2004; Jackson, Meltzoff and Decety, 2005). It is plausible that different representations of pain experienced by the self can inform and vary the way we experience pain in others. Observation of pain is a new and emerging literature that may offer insight into pain generated in the absence of injury, namely pain generated through observation of others in pain.

1.2 Models of Pain

1.2.1 Specificity Theory

Here we discuss past and present conceptual models of pain and how they explain pain generated in the absence of injury. The first model is commonly known as the specificity theory. This idea of pain as a physical expression of injury was first proposed by Rene Descartes (1664). He proposed that pain is a physical sensation, associated with bodily injury, to provide protection against further injury (Melzack, 2001). Descartes described pain as a warning system involving ‘threads’ that are set in motion by threatening stimuli such as a fire. These threads run through the body to a specialized pain centre in the brain. Descartes suggested pain as analogous to pulling a rope to ring a church bell. Consequently, he proposed a one-to-one relationship between injury and psychological experience (e.g. pinpricks may evoke a sharp intense sensation; bruises evoke a dull, gnawing experience and so on). Although a one-to-one relationship between stimulus and pain is hard to account for, in general specificity theory has some purchase, but there is a surprising degree of variability in the intensity of the experience from a given

noxious stimulus. The stimulus that creates the pain, e.g. a needle, is obviously identical in all cases but the pain experience associated with the stimulus is highly variable between individuals. For example Melzack, Wall & Tye, (1982) recorded reports of pain during emergency room admissions and found that 40 percent of patients reported no pain, despite extensive physical injuries. The absence of pain in the presence of extensive physical injury is difficult to reconcile with the specificity theory of pain. An extensive injury should evoke a proportionate amount of pain. In at least some cases, however, pain is not tightly linked to the objective external stimulus (e.g. a needle).

Specificity theory fails to take account of the subjective nature of pain. When pain experience no longer accurately reflects the stimulus or external noxious event then other

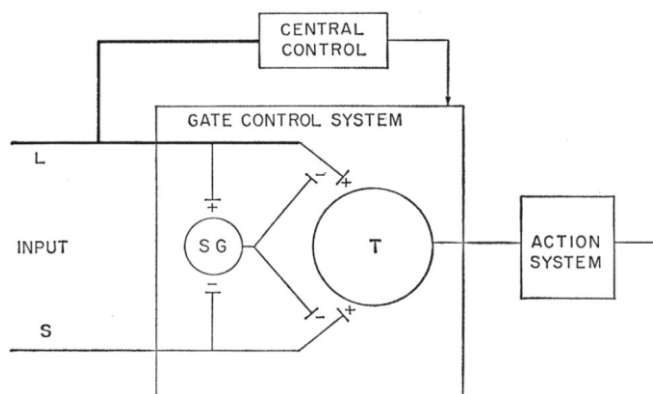

Figure 1.1: *L = large diameter fibers; S = small diameter fibers; SG = substantia gelatinosa; T = first central transmission cells; + = excitation; - = inhibition. Melzack and Wall's gate control theory of pain.*

factors might be considered to be important. This creates a number of problems, one of which is the lack of ability to account for the variability in pain experience normally called psychosomatic pain. Psychosomatic pain is said to generate from psychological or emotional factors such as stress.

Many theorists believe that if there is no objective evidence of pathology then pain does not exist. For example, Valerie Hardcastle (1997) purports that pain is best understood in terms of a biological system and that psychosomatic pain (pain of psychological origin) does not exist. She argues that it is the lack of understanding of the physiology of pain that prevents us from understanding pain experience.

According to specificity theory, injury causes pain by activating specialized pain fibres that relay information to a specialized pain centre in the brain. Prior to the gate control theory it was widely believed that the small diameter A δ and C fibres, which preferentially process noxious stimuli, transmitted noxious information directly to the brain without modification.

Melzack and Wall (1965), however, demonstrated that the large sensory fibres, which process non-noxious tactile stimuli, can inhibit noxious information. This is why rubbing an injured area can be soothing. The inhibition was proposed to take place via the substantia gelatinosa (SG) which receives input from the large and small sensory fibres. Large fibres activate the SG, which inhibits transmission cells (closing the gate), whereas small fibres inhibit the SG allowing the transmission cells to fire (opening the gate). The gate control theory (GCT) also included a descending influence from the brain that could close the gate. GCT was the first theory to include central processing in a model of pain processing. Consequently, Melzack and Wall provided a theory that could explain the variation in pain due to psychological factors. GCT emphasizes a variable relationship between noxious input and pain experience, while still allowing pain to follow peripheral noxious input. GCT focuses upon the role of external noxious input but also emphasizes the role of a central or psychological mechanism through which pain is experienced. As a result the GCT does not account for pain experience evoked entirely in the absence of any noxious peripheral input e.g. in cases of chronic lower back pain. It also fails to explicitly outline the role of psychological factors and how they contribute to variability in pain experience. In addition the role of central processing, as described by the theory, is not clearly explained. The extent and importance of central processing, and how pain is coded in the brain, are both vaguely explained.

1.3 Brain regions implicated in affect and sensory aspects pain

An attempt to resolve the vague notion of brain involvement in pain was the neuromatrix proposed by Melzack (1990). Recent advances in neuroimaging techniques such as positron emission tomography (PET) and functional magnetic resonance imaging (fMRI) have made it possible to study the brain during experiences of pain. It has been demonstrated that pain experience is coded in terms of sensory/discriminative and affective/motivational components. These two components have distinct corresponding brain regions. A popular term for the areas of the brain associated with pain experience is the pain neuromatrix. The sensory discriminative areas are subserved by the primary and secondary somatosensory cortices as well as the posterior insula. The affective motivation qualities of pain are coded primarily by the anterior cingulate cortex (ACC) and the anterior insula (AI). Distinct networks representing emotional and sensory aspects of pain highlight the involvement of sensory and emotional factors in pain perception. Patients with brain lesions that impair the connection between somato-sensory and emotional areas can detect noxious stimuli but display no signs of unpleasantness. Although the patients were able to detect the noxious stimulus, they exhibited little or no signs of discomfort or unpleasantness. The patients report that “the pain is still there, but it doesn’t bother me” (p 52, Grahek, 2001). It is believed that in the case of patients with pain asymbolia, the absence of connection between the somato-sensory areas and emotional areas reduces the pain experience. Pain without unpleasantness ceases to have both the sensory and emotional components of pain and no longer feels like it hurts or is painful.

It is also the case that experiencing the unpleasantness of pain without the accompanying physical sensations is also unlikely to constitute a complete experience of pain. People may explain a subjective experience couched in terms of pain and hurt which

are subserved by the same brain regions as physical pain (Eisenberg, Lieberman and Williams, 2003). In the absence of pain sensation there is merely unpleasant experience. Unpleasant experience without accompanying physical sensation is no longer a sensory experience. Pain without localized sensation is no longer a pain because the hallmark of pain is physical sensation.

It is unlikely that there is one to one experience of pain and neural output from brain activity created by a single stimulus. However, the pain matrix illustrates the very tight relationship between pain sensation and pain affect. Despite illustrating that pain experience is a mixture of sensation and emotion, the pain neuromatrix is only a description of brain areas associated with pain experience and does not offer a theory of pain processing or subjective pain experience. The problem of pain is highlighted by functional pain disorders.

1.4 Functional Pain

1.4.1 Prevalence of functional pain

Pain without an identifiable cause is typically referred to as ‘functional pain’ (Deyo, Battie, Beurksens, Bombardier, Croft et al., 1998) and encompasses other terms such as psychogenic, psychosomatic or medically unexplained symptoms. The term functional was introduced to escape some of the negative associations that imply pain of a psychological origin. Persistent intractable pain that develops in the absence of injury is predominantly classified as a psychological disorder, classified by DSM IV as function disorders (Bass, Peveler and House, 2001; Mayou et al., 1995). Despite the lack of objective physiological markers or injury, many patients report debilitating levels of pain experience (Arnold, Clifford, Mease, Burgess & Palmer et al., 2008). Prevalence for these

disorders ranges from 0.5% to 5% in developed countries (Angst, Brioschi, Main, Lehmann et al., 2006). Diagnosis is predominantly based on self report of pain persisting for 12 weeks or more without an identifiable biomedical cause (Schweinhart, Sauro & Bushnell, 2008).

1.4.2 The problem of functional pain

The severity of impairment in functional disorders can vary, with some patients becoming wheelchair bound (Bass and Murphy, 1991), and others having to leave employment (Henriksson and Burckhardt, 1996) or make other adjustments to their lifestyle e.g. restrict physical activity, (Soderberg and Lundman, 2001). Smith et al. (1986) reported that on average patients with somatic functional disorder spent seven days in bed every month. Diagnosis for functional pain disorders is problematic because pain is usually associated with an organic or physical marker and tightly linked to specific signs and symptoms. For example Rheumatoid arthritis (RA) is a disease characterized by pain, stiffness, inflammation of the joints and fatigue and is diagnosed based on objectively measured physiological characteristics, including an increase in rheumatoid factor (an antibody directed towards the organisms own cells) (Carson, Chen, Fox, Kipps, et al., 1987) and anti CPP (anti-cyclic citrullinated peptide antibody) (Kuhn, Khulik and Tumooka, 2006). Unlike the diagnosis of RA, functional pain, e.g. fibromyalgia and chronic lower back pain, are diagnosed without evidence of organic pathology. Diagnosis in both conditions is mainly based on self reported symptoms and/or tender point/mobility tests (Waddell, Feder, McIntosh, Lewis et al., 1996; Wolf, Smythe and Yunus, 1990). The problem associated with diagnosing a condition that has no physical marker is that the conditions are subjective and thus difficult or impossible to successfully treat. For

example, fatigue, muscle pain, reduced mobility and a lack of energy are all general symptoms common to other diseases or psychological problems.

1.4.3 Functional pain and mental health

Functional pain disorders are usually discussed as psychological problems because of the absence of organic pathology as well as concomitant mental disorders such as anxiety, depression, hypochondriasis and helplessness (Bayer, Baer And Early, 1991).

Psychological factors are believed to prolong acute pain so that the pain becomes a long

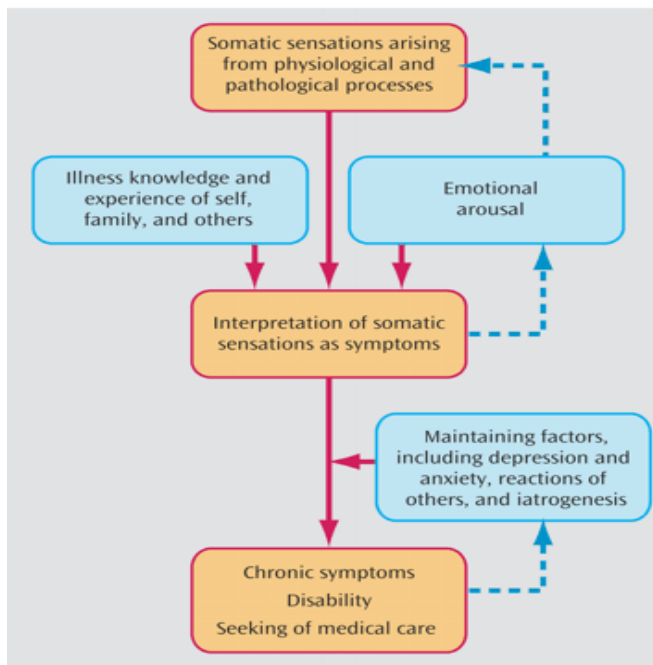

Figure 1.2 A model of factors involved in the generation of functional somatic syndromes, reproduced from Mayou, Bass and Sharpe (1995).

concomitant psychological problems are common in functional pain syndromes, it is difficult to ascertain the extent to which psychological factors play a part in the aetiology of chronic pain disorders. There have been few studies investigating the relationship between depression and fibromyalgia but none that have examined the causal relationship between the two (Fassbender et al., 1997). It is difficult to understand if patients with

term chronic problem, after the original injury has healed (Da Costa, Dobkin, Fitzcharles, Fortin, et al., 2000; Linton, Buer, Vlaeyen, & Hellising 2000).

Anxiety has been demonstrated to increase pain severity and pain behaviour in chronic pain patients (Kain et al., 2000) and also in

healthy controls (Rhudy and Meager, 2000). While

functional pain have psychological disorders such as depression because of their pain, or whether the psychological problems themselves are more central to the generation of pain.

1.5 Bridging the gap between psychological and physical pain

One theory which attempts to explain the more subjective nature of functional pain and the psychological influence upon pain sensation is the biopsychosocial model (BPS). The model was first applied to chronic pain by Waddell in 1987. The theory proposes that chronic pain is a product of a complex interaction of biological, cognitive, emotional and social factors. The interaction of the psychological and biological factors offers a plausible heuristic for understanding the subjective pain experience (Renn & Dorsey, 2005).

Although BPS offers a plausible heuristic for the chronic nature of pain, the theory does not elaborate on the interplay between psychology, biology and social influences. The biopsychosocial model attempts to bridge the gap between the mind and the body but does not explain how physical components such as pain, fatigue and tension are driven by psychological factors (Butler, Evans, Greaves and Simpson, 2004). Despite the acceptance that psychological factors play a part in pain perception, the onset of pain is still considered by medicine as largely as a product of physical injury or disease (Mayou, Kirmayer, Simon, Kroenke and Sharpe, 2005). In figure 1.2 the reliance on physiological mechanisms for generating pain, even within a biopsychosocial model, is illustrated. The model proposes that somatic sensations are interpreted as symptoms of illness and are perpetuated by psychological factors such as anxiety and depression. The putative assumption that symptoms are a product of a disease or physical problem is not, however, fully supported (Mayou et al., 2005). Ruo, Rumsfeld, Hlatky, Lui et al. (2003) demonstrated that symptom burden, physical limitation and overall health are not linked to actual disease severity in heart disease patients (i.e. ischemia) but were linked with depression. It is perhaps

unsurprising that patients who reported higher depressive symptoms were less likely to perform exercise and had poorer general health status. This research highlights the flexible relationship between physical symptoms and disease. The biopsychosocial model does not account for the generation of pain in the absence of injury. Recently new innovative methods have been adopted to investigate pain without injury.

1.6 Generating pain sensation without external noxious stimuli

1.6.1 Sensori—motor conflict

Pain experience in the absence of noxious stimuli has been demonstrated by McCabe, Haigh, Ring, Halligan, Wall and Blake (2003), the mechanism for which is described in terms of sensory-motor conflict. For example a sensory-motor conflict can arise when an intended action is matched to the intention, intending to kick a ball results in kicking the ball, and the sensory experience associated with the action is reduced. In contrast, when an intended action is not matched to the intention, intending to kick a ball results in kicking the ground, and the sensory experience associated with the action is increased. The sensorimotor system receives sensory feedback that the intended and perceived action are incompatible (Jeannerod, 1997). Our internal state is constantly being monitored and checked against real and self generated movement and action. It is thought that tickling provides a useful case study for this comparative system.

It is well established that we are not able to tickle ourselves; one of the reasons put forward to explain this phenomenon is sensory motor feedback. When we tickle ourselves, we intend to tickle ourselves, and the match between the intended outcome and perceived outcome dampen downs the tickle sensation as we are able to predict each movement. When we are tickled, the intended movement and the perceived movement are not

compatible because we cannot predict the intended movements of others. The mismatch between the intended and perceived action in this case results in uncomfortable tickle sensations (see figure 1.3).

McCabe, Haigh, Ring, Halligan, Wall and Blake (2003) hypothesized that a mismatch between visual information and motor commands could explain the functional syndrome chronic widespread pain syndrome (CWPS). McCabe et al. (2003) recruited patients who had CWPS for varying amounts of time from 3 weeks to 3 years, and who all reported pain in a single limb. Patients were seated and a mirror board was placed to hide the affected limb. Patients observed their healthy limb and the reflection of their healthy

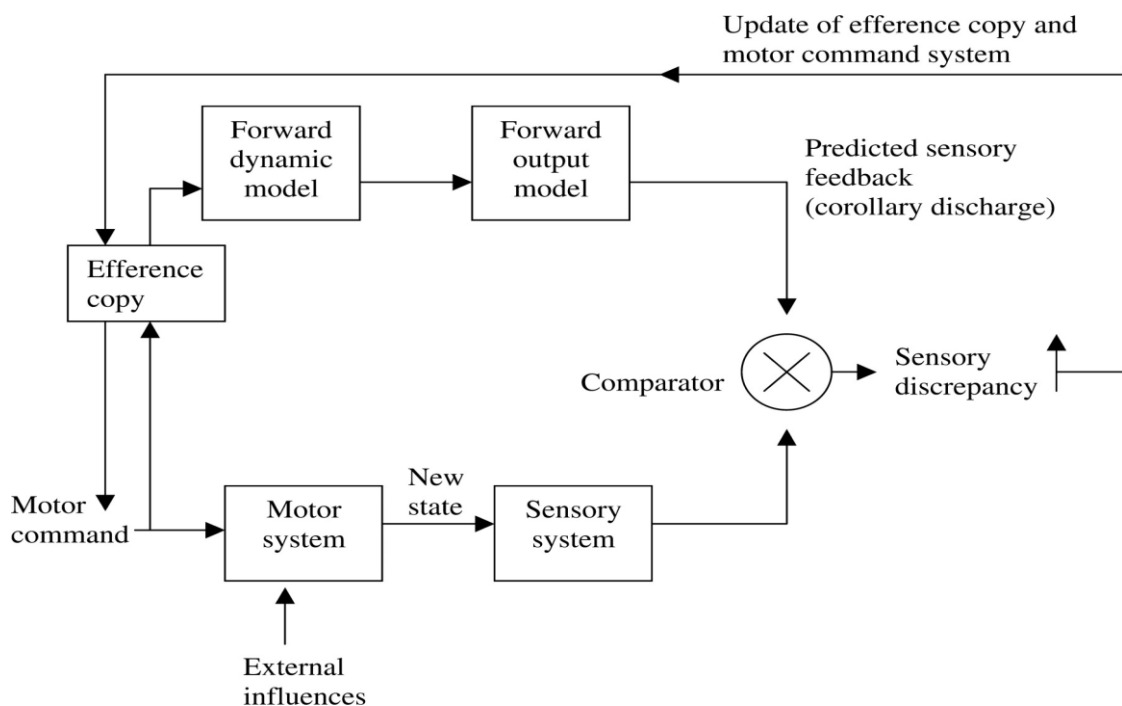

Figure 1.3: The role of the efference copy on the motor control system. A motor (efferent) command produces an efferent copy which contains predictions about the outcome of movement. The predicted sensory outcome is then compared (using visual feedback) with the actual sensory feedback. When the predicted outcome and the actual outcome are matched then there are no sensory disturbances. When predicted and actual outcomes are mismatched then there is an increased sensory disturbance resulting in transient somatic sensations such as pain, discomfort, temperature changes and weight changes.

limb in the mirror. They were then asked to produce flexion and extension type movements while focusing on the reflection of their healthy limb. Participants were

instructed to practice these movements for six weeks following the initial session. At six weeks, participants who were in the early stages of CWPS (less than eight weeks) reported a significant reduction in pain compared to the initial session. Patients who had experienced CWPS for longer than two years, however, failed to report a reduction in pain. The pain reduction suggests that a mismatch between the sensory-motor information could account for pain experienced in early CWPS. The absence of any improvements in patients who have experienced CWPS for over two years could reflect permanent changes to neural pathways occurring from prolonged pain experience (McCabe et al., 2003)

Using the same paradigm, McCabe, Haigh, Halligan and Blake (2005) suggested that painful sensation might occur as a result of mismatches between efferent sensory-motor commands and visual input in healthy subjects free from pain. Participants placed their arms either side of a mirror board with one arm hidden out of view (see figure 1.4a). They were then asked to move their arms up and down in synchrony (see figure 1.4a) or asynchrony (see fig 1.4b) whilst keeping their attention on the mirror feedback. When the



Figure 1.4: The procedure used in McCabe et al (2005). a) On the left is a participant carrying out congruent movement and, b) on the right, the same participant carrying out incongruent feedback.

movement was synchronous, the visual feedback was congruent (i.e. the participant's movement of the arm matched the visual input from the mirror feedback).

After completing the conditions,

participants reported that they felt a range of sensations in the occluded arm when moving asynchronously. These sensations included weight and temperature changes as well as mild pain and discomfort described as tingly, pins and needles, shooting or achy. This generation of pain in healthy volunteers demonstrates that pain and other anomalous sensory changes can be generated without peripheral input. McCabe et al. (2005) propose that central processes, presumably in the motor system, related to the mismatch between the predicted and observed movement, generate the reported sensations.

Around 15% of the sample experienced pain and around 60% of the sample reported at least one somatic change such as the hand getting heavier, colder, hotter, feeling of peculiarity, and either losing or gaining an extra hand. Not all of the participants reported sensory changes during the procedure, indicating that individual differences may be important.

Individual differences are likely to play a part in the generation of pain especially as a result of innocuous stimuli. A factor that has been shown to influence pain report is response expectancy. These participants presumably respond to the suggestion that they might be in pain in the same way that people will start to scratch if the presence of fleas is indicated.

Expectations that a drug will relieve pain is likely to lead to reporting of reduced pain sensation. High expectancy for suspected analgesic drug efficacy has been found to reduce reports of pain (DePascalis, Chiaradia, Carotenuto, 2002) as well as reducing pain perception in headache patients (Classen, Feingold, Netter, 1983). Expectancy of pain may play a role in the reporting of pain in the absence of external noxious stimulus although it is unlikely to provide a comprehensive explanation.

1.7. Acute Pain Symptoms with no obvious cause

Most of the focus of pain without injury is on long term pain, because pain that disappears with no medical intervention places no burden on the medical systems. Acute pain is usually generated by physical injury and is thought to last for around one month (Merskey and Bogduk, 1994). However, acute unexplained pain is also common (Barsky and Borus, 1999). Transient physical symptoms such as headache, fatigue, back pain and stomach upset, continue to occur in otherwise healthy populations (Ricci, Chee, Lorandeanu and Berger, 2007). In one study, around 60% of symptoms including pain reported at a doctor's surgery in Holland were unaccounted for by physiological problems (Van Hemert, Hengeveld, Bolk, Rooijans, et al., 1993), although prevalence for chronic pain disorders is much lower and ranges from 0.5% to 5% in developed countries (Angst, Brioschi, Main, Lehmann et al., 2006). Diagnosis is predominantly based on self report of pain persisting for 12 weeks or more without an identifiable biomedical cause (Schweinhart, Sauro & Bushnell, 2008).

Unexplained painful symptoms pose a problem for current pain theories which assume that pain is generated primarily from organic pathology. The triggers for unexplained acute pain are unknown, as few studies to date have generated sensations of pain without injury in an experimental environment.

1.7.1 Mass Psychogenic Illness

Evidence that somatic symptoms can occur without physical origins and in a social environment is documented by case studies of 'mass psychogenic illness' (MPI). MPI refers to the signs and symptoms attributed to an external cause rapidly exhibited by individuals in the same group (Jones, Craig, Hoy, Gunter, et al., 2000). In the year 2000, a high school teacher noticed a smell of gasoline in the classroom and started to report

headache, shortness of breath, nausea and dizziness in front of pupils (Jones, et al., 2000). She was taken to hospital along with several students from the same class. During the same day, a further 100 people visited the emergency room with symptoms they believed to be due to toxic exposure. In total, 68% percent of people surveyed after the incidence believed the symptoms to be a result of the toxic exposure. Extensive investigation by environmental government agencies revealed no evidence of toxic substances in the atmosphere.

Struewing and Gray (1990) reported a similar incident in a group of army soldiers who were hospitalized after believed exposure to toxic gases. One thousand recruits developed at least one symptom after the exposure, 375 received further medical attention and eight were hospitalized reporting symptoms such as shortness of breath, sore throat and chest pain. Extensive investigations revealed that, as in the case reported above by Jones et al. (2000), there was no evidence of toxic gas in the atmosphere. It is possible, although unlikely because of the number of cases without explanation, that pollutants did exist but were not correctly identified. Aldous et al. (1994) reported that a high number of school girls exhibited common mass psychogenic illness symptoms like nausea, vomiting and stomach pains, however cucumber pesticide contamination was attributed to the bout of illness.

Unexplained somatic symptoms are also not isolated to toxic environmental hazards. Halvorsen, Crooks, LaHart and Farrell (2008) highlight the case of itching contagion during an outbreak in an infant school. Initially several pupils in one classroom began to complain of itching and irritation to their skin. Over the next few days 93 visits were made to the health room with complaints of itching; similar to the examples above

there was no obvious initial cause for the itching. Days later reports of itching or skin redness returned to normal.

1.8 Shared somatic experiences

Shared somatic experiences have only been found to be induced experimentally in a few cases. Observing the behaviour and sensations of others can lead to the experiencing of those sensations; for example, Pennebaker (1982) demonstrated that people were likely to scratch if they observed another scratching. In a more recent study, Mazzoni, Foan, Hyland and Kirsch, (2010) asked participants to inhale an inert substance which they believed caused four main symptoms: headache, nausea, itchiness and drowsiness. Half of the participants observed a confederate inhaling the same toxic substance. Mazzoni et al. demonstrated that participants who observed the confederate inhaling the substance and reporting symptoms in front of them were more likely to report physical symptoms themselves. The exact mechanisms for this contagious spread of symptoms are unknown, however it is likely that individuals who were open to the experiences of others were more likely to experience symptoms. A possible limitation of this study is that observation of inhaling the substance and reporting of symptoms was conflated. It is possible that just the reporting of symptoms is enough to confirm the adverse effects of the believed toxic substance and not the role of observation of another per se.

1.8.1 The development of somatic symptoms

Observing somebody else experience illness is sufficient to modulate future experiences of symptoms associated with illness (e.g. pain) (Turk, Guise and Carter, 1983). Koutanji, Pearce and Oakley (1998) demonstrated a relationship between familial pain symptoms and the participants' own pain reports. For example, if participants reported the

incidence of headaches, joint or muscle pain in their family then they were more likely to experience those specific symptoms. It is unclear whether social learning or genetic factors underpin reports of pain linked to family models of pain. However, support for the social learning of pain has been demonstrated experimentally, for example, Levy, Jones, Whitehead, Feld et al. (2001) demonstrated greater predictive value of social learning factors over genetic factors using questionnaires with a sample of over 10,000 twins. Turkat, Guise, and Carter (1982) exposed a group of participants to a confederate with low and high pain tolerances. Participants exposed to high pain tolerances exhibited higher pain tolerances from baseline in comparison to the group who had observed the confederate with low pain tolerances. Research on exposure to painful events suggests that those who observe painful symptoms are more likely to report painful symptoms throughout their life. The development of these somatic symptoms can also be observed in toddlers (Wolff, Darlington, Hunfeld, Verlhurst, Juddoe, et al., 2010). The development of these pain symptoms appear to be shaped by their meaning and interaction with others (Bandura, 1977).

1.8.2 Affect and symptom reporting

Kirwilliam and Derbyshire (2008) have provided evidence that pain is reported in the absence of any noxious stimulation. They did this by priming participants with pictures of unpleasant stimuli (mutilation, pain, etc.) or neutral stimuli (everyday items and scenery) using the dot probe task. Afterwards, participants reported whether they felt pain or heat in response to a series of heat pulses. Participants primed with unpleasant images were more likely to report the heat pulses as painful and were more likely to report feeling a pulse, and feeling it as painful, even when no pulse was delivered. The findings demonstrate that, after we see unpleasant stimuli that are likely to evoke a short term

negative emotional state, we are more likely to experience pain even in the absence of a noxious stimulus. The findings could be due to greater attention or associated hypervigilance to pain stimuli evoked by the initial unpleasant images (Sullivan, Martel, Tripp, Savard and Crombez, 2006). This paradigm demonstrates that acute pain experience can be reported in the absence of noxious input.

1.9 Response expectancy and pain without injury

Vicarious somatic symptoms are largely described as a social phenomenon, and are often associated with suggestion or response expectancy summarized in this quote “those who accepted the idea (somatic symptoms) succumbed and those who were indifferent to it were immune” (Goh, 1987, p. 67). Expectation of a painful event has been found to elicit reports of pain; for example Schweiger and Parducci (1982) told participants that they were to receive an electric current to their head. In the absence of any electrical current, participants still reported headaches, presumably because they expected to feel pain. Gollub, Pollish, Kirsch, LaViolette, Vangel et al. (2008) demonstrated that induction of pain through expectation resulted in reports of pain and also corresponded to areas of the pain matrix believed to code affect (medial pain system) typically during the presence of a noxious stimulus. Gollub et al. (2008) suggest that, because of the activation of the medial pain system, processing of pain induced by the expectancy of pain is predominantly modulated by affective processing. Support for affective processing during expectancy of pain has also been found using physiological measures. Heart rate recorded during pain experience induced by pain expectation correlates with pain unpleasantness but not with pain intensity (Rainville, Carrier, Hofbauer, Bushnell et al., 1999).

1.10 Affect and observation of others in pain

Observing another in pain has also been associated with affective components of pain. Watching somebody else injure themselves is likely lead to an understanding of what that pain is like, often expressed by “ouch, that hurt” or, “I felt that”, etc. These types of reactions are commonplace but Singer et al. (2004) showed female participants cue cards that signalled their partner was about to be hurt. In this condition, activation was found in the anterior cingulate cortex (ACC) and the insula, areas commonly activated when participants directly experience a noxious stimulus. In a similar study, Jackson et al. (2005) showed participants images of other people in common painful situations (e.g. chopping their finger whilst preparing food or trapping their hand in a door). Jackson et al. also reported ACC and insula cortex activation. These findings imply a shared emotional response when observing another in pain that is mediated via activation of the ACC and insula.

1.10.1 Embodied simulation

An empathic response, for example, being brought to tears by observing an actor in an emotional scene of a film, is a shared representation between the observer and the observed. Evidence supporting the idea of shared representation in social interaction has emerged from perception-action research. Single cells are found to fire in the prefrontal cortex of the macaque in response to observing goal directed actions as well as performing goal directed actions (Rizzolatti et al., 1996). The finding that observation of action evokes an identical response to that of carrying out the action has given rise to the idea of a mirror system within social interaction (Stamenov and Gallese, 2004). Mirroring or modelling of social behaviours is the principle that underlies the embodied simulation (Gallese, 2001). Generally, embodied simulation suggests that perceiving the state of another evokes a

representation of that state in the observer (Decety and Lamm, 2007) and is based on the idea that perception and action have shared properties. For example, shared properties have been demonstrated not only with actions but also with emotions like disgust. Wicker, Keysars, Plailly, Royet, Gallese et al. (2003) asked participants to smell unpleasant odours that elicited disgust and watch others smelling the same disgusting odour. They demonstrated overlapping activation in the left anterior insula when both inhaling and watching somebody else inhale the disgusting odour. Observation of another experiencing disgust is coded with reference to how disgust is experienced in the first person perspective. Emotion is tightly linked to the sensory-motor systems; for example Aldolphs (2000) highlights the cases of patients with lesions in whom the sensory-motor cortices were unable to recognise a variety of emotional facial expressions related to disgust. The exact nature of the link between sensory-motor systems and observing somebody else in pain is unknown.

1.11 Sensations and observing another in pain

Despite the evidence for a shared emotional response put forward by a collection of fMRI studies (Jackson et al., 2005; Singer et al., 2004) there has been some research investigating the link between sensory and motor systems while observing others in pain. Avenanti et al. (2005) used TMS to evoke motor evoked potential during the observation of a needle being inserted into a hand. The findings demonstrated corticospinal inhibition of the muscles related to the injected hand and also a correlation between pain intensity and levels of inhibition. Thus Avenanti et al. (2005) demonstrated sensorimotor mapping when observing another person receiving a noxious stimulus. Bufalari et al. (2007) directly measured somatosensory-evoked potentials(SEP) when observers viewed a needle inserted into someone else's hand. They found an increase in the amplitude of the SEP when

participants observed the needle being inserted compared to observing the hand being touched by a cotton bud. There was also a positive significant correlation between the perceived pain intensity evoked by injection to the hand and SEP amplitude. These findings suggest that somatosensory activation is directly modulated by observation of another in pain.

There is increasing evidence that observation of pain modulates central processes associated with the emotional and sensory feel of physical pain in the observer. If observing pain in another can activate emotional and sensory regions of the brain, it is possible that at least some observers will have a phenomenological experience of pain.

Avenanti et al. (2008) investigated the specific effects of state and trait empathy upon modulation of motor evoked potentials. He found that state empathy interpreted as the perceived judgement of pain intensity in the model was inversely correlated with changes in motor evoked potentials. That is to say, participants who rated the stimuli as more intense demonstrated an increased motor inhibition. Given the differences in motor inhibition, it could be the case that participants may also have different behavioural responses to the pain of others.

1.12 Touch Synaesthesia

A number of studies have investigated the experience of touch as a consequence of watching another person being touched. Blakemore, Bristow, Bird, Frith, & Ward (2005) reported the case study of a female who always felt touch when observing somebody else being touched. She reported that the feeling was quite normal and was quite surprised to find out that this was an unusual experience. Blakemore et al. (2005) termed this vicarious

experience ‘mirror-touch synaesthesia’. S1 activation was observed during actual physical touch but also when the touch synaesthesia participant observed another being touched.

Bannisey and Ward (2007) further investigated touch synaesthesia by showing videos of other people being touched on the face while an actual touch was delivered to the participant’s face. Participants were asked to distinguish between actual touch to their face and touch felt as a result of watching somebody else being touched. Participants failed to distinguish between actual touch and touch evoked by observation. Touch synaesthetes also scored significantly higher than controls on the subscale of the empathy scale measuring cognitive abilities such as perspective taking (Lawrence, Shaw, Baker, Baron-Cohen and David, 2004).

1.12.1 Synaesthesia and Pain

A body of research has recently emerged describing a phenomenon similar to mirror-touch synaesthesia. Instead of the sensation of touch being generated by the observation of touch, the sensation of pain is generated by the observation of pain. Fitzgibbon, Guimara, Kianistianis, Enticott and Bradshaw (2010) discuss pain generated in the absence of injury in terms of ‘pain synaesthesia’. Synaesthesia is usually described as a confusion or crossing of senses (Ramachandran & Hubbard, 2001). Graheme-colour synaesthesia is the most common form of cross-modal synaesthesia (i.e. colour experience generated by the observation of letters or numerals). The term pain synaesthesia will not be adopted in this thesis because it is problematic. Observing another in pain causes an actual sensation of pain in oneself. Seeing pain and feeling pain or a sense of what it is like for that person to be in pain is not similar to other accounts, or more traditional accounts, of synaesthesia. On presentation of a painful stimulus it is advantageous to assess the potential harm of a stimulus. When we see something painful happen like somebody

tripping over or a footballer sustaining a sporting injury, we are likely to some extent to share their experiences. We understand what it is like to feel pain and we to some extent feel what it is like to experience that pain. People with sensitive teeth feel pain and find it difficult to look at somebody eating ice cream because it hurts them. There is an apparent motivational significance for sharing a pain experience. In contrast, perceiving Tuesday as “yellow” or tasting a bitter taste at the same time as hearing a C# note, which are common examples of synaesthesia, has no particular relevance or motivational significance with respect to the original stimulus. The eliciting stimulus and perceptual experience do not share any obvious experiential qualities.

On the other hand, a visual experience of pain and a physical experience of pain share many experiential qualities as demonstrated by the empathy for pain literature (e.g. Jackson et al. 2005; Morrison et al., 2004; Singer et al., 2004). Observation of something or someone evokes emotional and/or visceral/physical qualities. For example, observing somebody eating an insect may evoke feelings such as disgust or surprise in the observer. Listening to a song is not just an auditory experience; it can produce a range of emotions and create changes in mood. Painful visual stimuli, whether in real life or depicted in pictures, result in a number of experiences generally described under the umbrella of empathy. Goubert, Craig, Vervoort, Morley & Sullivan et al. (2005) divide the factors involved in the sense of knowing what it is like to for another to be in pain into two main areas: affective responses (oriented towards self, personal distress and oriented towards the other, sympathy, empathy) and behavioural responses (withdrawal and reassurance). Knowing what it is like for another to be in pain requires external factors such as the extent of the injury, facial expression, context and top down factors like past pain experience, sensitivity to pain, etc.

1.13 Case studies of pain in the absence of injury

Although there is much evidence to suggest that touch can be felt during the observation of touch, there are no studies reporting that pain can be felt during the observation of injury. A number of case studies, however, have reported pain in people expecting or observing an injury. Fisher, Hassan, & O'Connor (1995) reported that a builder felt excruciating pain after accidentally stepping down onto a 15 cm nail which went completely through his boot. The builder was sedated and given fentanyl upon arrival at hospital, but when his boot was removed it became apparent that the nail had not penetrated his foot at all. The nail had passed between his toes without any injury. Presumably the belief that the nail had penetrated the foot and the expected pain was enough to trigger a pain experience.

1.13.1 Pain Flashbacks

More recently Whalley, Farmer, & Brewin (2007) described the case of a post traumatic stress disorder (PTSD) patient who had been seriously injured during the London bombings of 7/7/2005. Each time that he received a cue about the bombing, particularly during therapy, the patient experienced varying degrees of pain. In the period since the injury he reported over 40 episodes of pain. One explanation for these pains is the reactivation of a pain memory (Katz and Melzack, 1990; Whalley et al., 2007) although, contrasting research using healthy volunteers has found little evidence of reactivation of a pain memory (Chen et al., 2008; Morley, 1993). It is likely that the associated severity of the injury and/or the traumatic, unusual circumstances surrounding the injury may play a part in the activation of pain in this case, and in phantom limb patients.

1.13.2 Watching another in pain generates pain sensation

Bradshaw and Mattingley (2001) reported the case of a man who felt pain in his hand when he observed his wife accidentally cutting her hand when preparing food. The man was a patient suffering from neuropathic pain and was also thought to have parietal lobe damage. Unfortunately, doctors were not able to ascertain the exact damage because the man died before scans were taken. Giummarra and Bradshaw (2008) described similar vicarious pain experiences in a cohort of phantom limb patients. Phantom limb patients were asked in retrospect “does anything trigger or cause your phantom limb sensations or phantom limb pain to emerge or change?” A small number of the phantom limb patients they have studied describe pain in their amputated limb when observing pain related stimuli such as facial grimacing, war and other traumatic events on television, or when hearing an unpleasant pain related story or event. It is difficult to ascertain if there is any link between the phantom limb pain itself and pain that is generated by visual /auditory information about others in pain. For example it is possible that imagination of pain triggers pain memories or experiences associated with or before amputation. Examples of pain without injury have not been reported outside of patients linked to trauma or have not been demonstrated experimentally.

1.14 Thesis Summary

The cause of functional pain is unknown, only few studies have investigated mechanisms which generate pain without organic injury (e.g. Derbyshire et al. 2004). Functional pain is generally defined by an absence of identifiable tissue damage or brain lesion/abnormality. Organic pain however, is generated by tissue damage or by damage to part of the brain. For example, in the case of post stroke pain, lesions to parts of the pain pathway such as the thalamus or insula are associated with painful sensations isolated to a

single limb. Functional pain is distinct from organic pain as there is little evidence to suggest that pain generated in people who experience functional pain (e.g. chronic lower back pain and Fibromyalgia) stems from an organic problem. One of the main barriers of studying functional pain is the lack of methods of generating pain without injury. While this thesis does not specifically address the cause of functional pain, it will focus on the generation of pain without injury in healthy individuals which may contribute to our understanding of functional pain. More specifically, this thesis will focus on the generation of pain in healthy individuals by investigating how mapping between self and other and how that could potentially lead to an experience of pain. Research has demonstrated that observation of pain leads to a partial overlap between self representations and other representations. This is reflected both by shared brain areas with areas coding emotional aspects of pain and behaviourally by expressions of empathy or personal distress (e.g. “ouch, that hurt” or looking away) (Jackson et al., 2005; Singer et al., 2004). To date, there has been no research with a healthy sample investigating the reports of physical pain without injury. The aim of this thesis is to investigate reports of physical pain during observation of others in pain. To do this, the second chapter will research the incidence of pain reports generated by the observation of pain and factors influencing the reports of pain. The third chapter will investigate the neural correlates of the pain generated by observation of others in pain. Chapter Four will investigate how reports of pain are linked to motor responses measuring reaction times. Chapter Five will investigate the perspective taking abilities of pain responders and Chapter Six will investigate the sense of body ownership in pain responders. Chapter Seven will discuss the implications of pain reports during the observation of pain.

CHAPTER TWO: PAIN SENSATION GENERATED BY OBSERVATION OF OTHERS IN PAIN

2.1 Introduction

Several anecdotal cases have described pain sensation without apparent noxious stimulation. A patient with parietal lobe damage reported that he felt pain in his finger when observing his wife accidentally hurt her finger (Bradshaw and Mattingley, 2001). In another case, a builder reported severe pain in his right foot after jumping down onto a 15 cm nail that seemingly passed through his foot. Careful removal of his boot revealed the nail passing directly between his toes with his foot entirely uninjured (Fisher, Hassan, O'Connor and Minerva, 1995). A male who suffered injuries because of bomb attacks on the London underground reported feeling over 40 flashbacks of pain sensation, especially when reliving the experience (Whalley, Farmer and Brewin, 2007). These case reports demonstrate that pain can occur because of sensory input that is not inherently noxious and, at least occasionally, pain might be directly shared with another person.

Amputees who experience a phantom limb report pain sensation in the phantom evoked by the sight or imagination of another person in pain, or other pain related stimuli (Guimmará and Bradshaw, 2008). Fitzgibbon, Guimmará, Georgiou-Karistianis, Enticott and Bradshaw (2010) review the case of pain reports from amputees generated by visual, verbal or imaginatory painful information about another. Amputees were asked if their phantom pain was induced or worsened by any other known factors. Eleven out of 280

participants reported pain generated by observing another person hurt themselves, observing pain related stimuli e.g. trauma, blood, etc., or thinking about others in pain (Guimmará and Bradshaw, 2008). In some cases phantom pain was worsened by observation of another in pain and in others it was entirely generated by the observation of another in pain. Phantom limb pain affected by observation of others in pain demonstrates that external inherently non-noxious visual stimuli can create pain. Fitzgibbon et al. (2010) label pain generated by observation of another in pain as ‘pain synaesthesia’ and emphasise that this phenomenon has only been demonstrated in a clinical phantom pain population. The majority of phantom pain amputees had experienced chronic pain for up to 13 years prior to amputation. Past pain experience is likely to influence ‘pain synaesthesia’ but mechanisms involved in this new phenomenon are largely unexplored. It is uncertain whether this type of painful experience occurred as a consequence of the amputation or whether ‘pain synaesthesia’ was present prior to amputation and has been exacerbated by the phantom limb pain. The demonstration of a group of phantom pain patients who retrospectively report pain generated by pain in others raises the question whether pain generated by observation of others in pain is prevalent in healthy individuals.

Generating pain without a noxious external input has been a barrier to understanding chronic pain. The long term presence of pain without injury characterises a large group of patients who are largely refractory to treatment (Barsky and Borus, 1999). The persistence, intractability and apparent lack of peripheral cause for their pain have led to an increasing interest in neuropsychological mechanisms (Borsook, Moulton, Schmidt, Beccera, 2007). A major barrier to understanding pain without injury, however, is the absence of techniques to generate pain without injury under controlled conditions. If there is an overlap between brain areas that code painful information when we observe others in pain, it is possible that in some cases observing

others in pain can lead to an experience of pain in the observer. Hence, this chapter will first explore whether healthy participants report pain when they observe another in pain.

2.2 Method

2.2.1 Participants

108 (22 male; mean age 26.4, range 18-55) healthy participants provided informed consent and received course credit for their participation. We did not explicitly ask participants if they suffered from chronic pain as we assumed that the participants were healthy. All participants were free from neurological or psychological disorder.

2.2.2 Visual Stimuli



Figure 2.1 *The images used to elicit pain for the behavioural study*

Seven images and three movie clips were selected from the internet using an image search

facility. The selected images are illustrated in figure 2.1. The three movie clips included a person's hand receiving an injection, a tennis player turning over their left ankle and a soccer player breaking their right leg.

2.2.3.2. Numerical Rating Scales

After viewing each image or clip participants were asked “How much pain do you feel?” The scale was anchored at zero for no pain and at ten for most pain imaginable. There were a further two subscales of pain experience which referred to the intensity and the unpleasantness of the pain experience. Participants who reported pain were asked to fill out both pain intensity and pain unpleasantness scales. When no physical sensation was elicited, participants were only asked to complete the NRS scale (0-10) for the emotional qualities of the pain. Participants were asked to rate the levels of disgust, fear, sadness, unpleasantness and empathy on a numerical rating scale anchored from 0 (not at all)-10 (a great deal) (see appendix three). The same anchors were used to rate emotions associated with pictorial stimuli in the IAPS (Cuthbert, Bradley and Lang, 1996). The specific emotion labels were chosen because fear, disgust and sadness are three of the main emotions used to describe emotions elicited by pictorial stimuli in the international affective picture system (IAPS). Pictorial stimuli included in IAPS depict a range of scenes that could be classified as painful stimuli (e.g. body mutilation, dental procedures etc). The inclusion of additional emotional categories was an attempt to separate out a purely emotional response from a somatic response.

2.2.3.3 State and Trait Empathy Questionnaires

State empathy refers to a transient mood characterised by warmth and compassion evoked by a particular situation e.g. reading a story in which somebody is hurt or emotionally traumatised. State empathy was measured on a NRS from zero (no compassion, warmth or sympathy) to ten (the most compassion imaginable) scale by three

separate items i.e. compassion, warmth and sympathy. These constructs have internal validity (0.74) for measuring empathy (Oswald, 1996) (appendix three).

The interpersonal reactivity index (IRI: Davis, 1980, see appendix one) is a commonly used multi-dimensional tool for assessing trait empathy with four subscales: empathic concern, personal distress, perspective taking and fantasy. The cronbach's alpha for those respective subscales are 0.64, 0.76, 0.70 and 0.69. Trait empathy refers to the predisposition of someone who responds to actions or events in an empathic way. Empathic concern and personal distress measure emotional aspects of empathy, and perspective taking and fantasy measure the cognitive components.

2.2.3.4 The short version of the McGill Pain Questionnaire (Melzack, 1987)

If participants reported experiencing pain then they were asked to fill out an additional inventory called the short version of the McGill Pain Questionnaire (Melzack, 1987). This questionnaire is important as it enables participants to elaborate qualitatively on their experience of pain. It is used in both clinical and laboratory settings and is considered a reliable (internal consistency 0.71) and valid tool for measuring pain experience (Melzack and Katz, 1994). The questionnaire has 15 pain descriptors (e.g. throbbing, shooting, gnawing, and sickening) linked to the sensory, affective and evaluative aspects of pain experience. The participant must choose the pain descriptor that best represents the feeling of pain evoked by the image. They are also able to locate the sensation of pain by circling the most appropriate area of human figures on the questionnaire (see appendix two).

2.2.3.5 The somatic checklist

Individuals who report the incidence of multiple physical complaints of unknown origin are thought to have an increased awareness of their own bodily sensations (e.g. pain, nausea, vision problems, etc.). Increased sensitivity or awareness of bodily feelings or sensations without obvious physical origin or sensations is known as somatisation (Mehling, Gopisetty, Daubenmeyer, Price et al., 2009). The expression of somatic symptoms is linked to increased emotional distress and to clinical disorders such as depression and anxiety (Charles, 2009) but often occurs without concomitant psychological disorders such as irritable bowel syndrome (Kroenke and Swindle, 2000). Physical symptoms without obvious pathology are common (Nimuan, Hoptof and Wesseley, 2001) with as many as 60% of patients attending medical clinics receiving no biomedical explanation for their symptoms (Nimuan et al., 2001; Van Hemert, Hengeveld, Bolk, Rooijans, et al., 1993). The most common acute unexplained symptoms are fatigue and pain (Kirkwood, Clure, Brodsky and Gould et al., 1982). A heightened awareness of bodily sensations, such as pain, is suggested to originate from top down control as opposed to afferent input. Bogaerts, Van Eylen, Li, Bresselleers, Van Diest, et al. (2010) induced dyspnea (increased need to draw in oxygen) to varying degrees in a group of patients with medically unexplained symptoms and a group of controls. They demonstrated that symptoms associated with dyspnea were more frequently reported in the MUS group, despite the absence of any physiological changes. Pain generated in the absence of any noxious stimuli is an unexplained experience presumably linked to top down control likely influenced by past experience (Fitzgibbon et al., 2010) and emotional processing (Singer et al., 2004; Botvinick et al., 2005). It is possible that pain responders are more likely to experience other unexplained physical experiences, such as blurred vision, stomach cramps, aches and pains and dizziness. These unexplained physical sensations may or may not be triggered by injury in others. In order to assess whether pain responders feel and

experience sensation without obvious physical origin, participants were asked to complete the somatic checklist. The somatic checklist is a list of 13 different physical sensations (e.g. blurred vision, feeling faint and dizzy, trouble catching your breath, etc.) devised by Pennebaker (1982) (cronbach's alpha 0.76) and used to assess increased somatic awareness in patients with chronic fatigue syndrome (Wood, Bentall, Gopfert, Dewey and Edwards, 1994). Subjects respond with the extent to which these experiences occur, from one (not at all) to five (a great deal) (see appendix three).

2.2.3 Procedure

All participants first completed the Interpersonal Reactivity Index (IRI). Participants then viewed a computer screen at a comfortable distance of approximately one metre. A standardised set of instructions was used to explain the procedure. Participants were informed that they were to view a series of images and short movie clips. Immediately after viewing each image they were to report if they felt any sensation of pain while viewing the image. It was emphasised that the pain should be felt in the body and that general feelings of disgust or unease should not be recorded as painful. The participants were then shown the numerical rating scale (NRS) used to rate the pain (anchored at zero for no pain and at ten for most pain imaginable) and the short-form McGill Pain Questionnaire (MPQ) (see appendix two).

The investigator sometimes asked additional questions to clarify that the nature of the experience was somatic rather than visceral or emotional. The nature of the vicarious pain sensation such as the location and the description of the pain, i.e. whether it was sharp, cramping, sickening, etc., were very important. Due to the unpleasant nature of the

images it was likely that participants may feel nauseous or sick as a result. In an attempt to be more stringent and avoid confusion between pain and sickness/visceral discomfort we decided to discount all types of stomach pain. Pain reported in the stomach area may be more representative of a visceral, disgust type pain best described as an emotional response.

Once the questionnaires were complete and the investigator was satisfied that she had sufficient information regarding the nature of the experience, the experiment continued with the next image or movie clip. In total, the experiment lasted 15-30 minutes depending on the range of responses.

2.3 Results

2.3.1 Pain Reports

Thirty one of the 108 subjects felt pain in response to at least one of the ten images. We included both images and video stimuli in the initially in the experiment because we were unsure of what type of image would elicit feelings of pain. However as participants reported pain when they viewed both images and videos we refer to both the image and video footage together as painful stimuli. All 31 felt their pain in the same location as the observed injury. For example, if the subject observed a finger injury, he or she marked a cross on the finger of the figure on the MPQ. The subjects selected a wide range of somatic descriptors from the MPQ. 'Tingling' was chosen as a descriptor most often (21 times) followed by 'aching' (18), 'sharp' (13), 'shooting' (11), 'throbbing' (8), 'sickening' (5), 'splitting' (5), 'heavy' (5), 'stabbing' (5) and 'tender' (1).

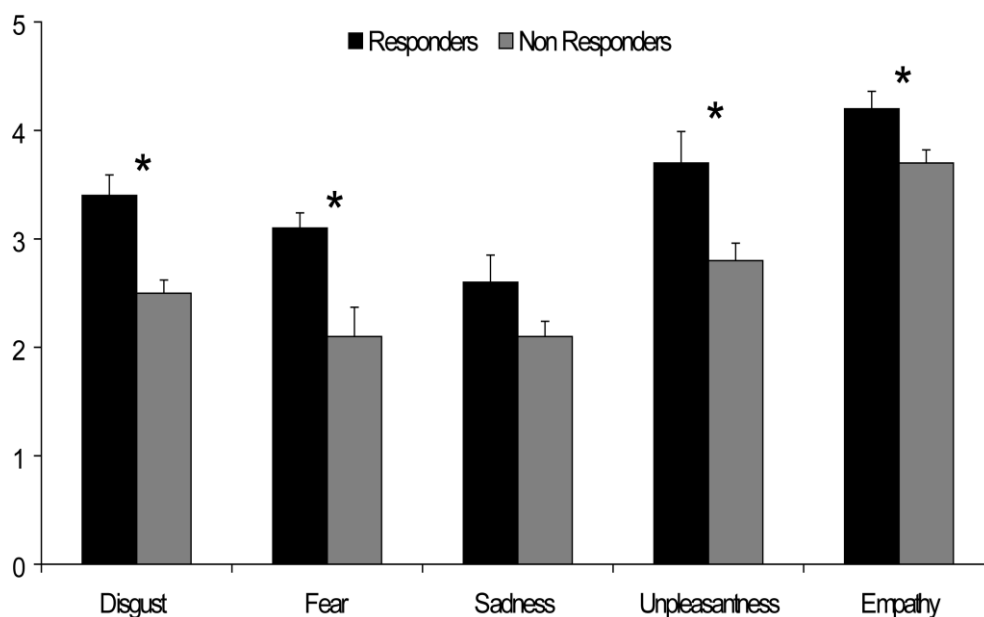

Figure 2.2: Mean ratings for disgust, fear, sadness, unpleasantness and state empathy for subjects who responded with pain (pain responders) to at least one of the images or clips in comparison to mean ratings for subjects who did not report any pain (non pain responders).

The duration of the pain was described as lasting for a “few seconds”, “fleeting” or “for a split second as soon as the picture appeared”. The picture of the athlete with the broken leg generated the highest pain intensity (mean rating 3.7) and the most frequent pain reports (17 of the 31 responders reported pain in response to this picture) (see fig. 2.2).

The picture of the man fallen from his bike generated the lowest pain intensity (mean rating 0.5) and the least frequent pain reports (4 of the 31 responders reported pain). The average pain intensity reported by the responders across all the images was 1.9 (SD=2.4). The average pain unpleasantness reported by the responders across all of the images was 2.8 (SD=3.0) and 1.1 (2.1) for non pain responders.



Figure 2.3: Comments made by pain responders after completing the experiment and an example of the localised nature of the pain and how participants marked the McGill pain questionnaire after observing the images.

Pain intensity, however, was not significantly correlated with state empathy ($r=0.17$), empathic concern, ($r=-0.50$), perspective taking ($r=-0.35$), fantasy (-0.33), personal distress ($r=0.25$), unpleasantness ($r=0.03$), fear ($r=0.15$), disgust ($r=0.01$), sadness ($r=0.27$), age ($r=0.02$) or gender ($r=0.17$).

2.3.2 Somatic Symptoms

An independent t-test was performed to investigate the differences on overall scores on the somatic checklist. Non pain responders reported slightly more experiences of somatic symptoms than pain responders (PR: $M=21.9$, $SD=3.3$, NPR: $M=23.1$, $SD=5.7$), however the difference was not significant between groups ($t(49) = -.86$, $p > 0.05$). Forty-seven percent of participants in the pain responder groups reported that they experienced “an ache in the last month that lasted longer than one day” compared to 35% of non pain responders.

Subjects were asked if they get this type of pain in everyday life or at the movies. Most of the sample answered that they did get unexpected sensations of pain,

or explained that they cannot watch films or documentaries that include images or scenes of pain because of these accompanying pain sensations. Subjects spoke about their pain experience during observation of another in pain as if it was normal; something they assumed was representative of the population as a whole.

2.4 Discussion

Here we demonstrate that a significant minority of participants reported pain when they observed another person in pain. Participants who responded to the images with pain will be referred to as pain responders. This is the first study to demonstrate that physical sensations of pain are generated by observing another in pain in a sample of healthy controls, which adds to the existing body of literature reporting other vicarious sensations, such as touch (Bannissey and Ward, 2007; Blakemore et al., 2005). Long term pain without injury is a problem that costs health systems millions of pounds each year. It is difficult to generate in a controlled experimental setting because there no techniques that induce pain without a noxious stimuli with the exception of hypnosis (Derbyshire, Whalley, Stenger and Oakley, 2004) or expectation (Kirsch and Lynn, 1997). Discovering a technique that reliably generates pain in healthy controls gives us a method to explore types of pain experience not obviously linked to tissue damage.

Pain responders were able to indicate the exact location of the pain which suggests that there is a direct spatial mapping between the injury observed in the image and the pain experienced by the individuals. Similar experiences have been demonstrated with touch (Blakemore et al., 2005; Bannissey and Ward, 2007), suggesting there may be a more general mechanism underlying the pain experience generated from images of others in pain. Mirror neurons, first discovered in action recognition research (Rizzolatti, Fadiga,

Gallese, and Fogassi, 1996) are often used to explain experience that is shared by both the observer and the observed, and have also been implicated in empathy for pain (Singer et al., 2004; Jackson et al., 2005). Mirror neurons are generally used to describe an overlap between brain regions involved in both processing of self pain and the pain of others. In action recognition literature, mirror neurons respond to the action itself, not to the static body part (Jeannerod, 2004). It is unclear what special mirror qualities neurons in the pain matrix possess, especially as mirror neuron activity is closely linked to action and not to static images. It is also important to consider that research into emotion and the MNS has received very little attention and is poorly understood (Agnew, Bakoo and Puri, 2007).

Whilst there is overlapping of brain areas involved in processing of pain in self and others it is assumed that self and other remain distinct; in other words, “I am separate from the person that I am observing”. Research investigating self/other distinctions in which participants are asked to adopt either their own or another’s perspective (Jackson et al., 2006) have separated out the different perspectives whilst processing pain in others using fMRI. Different pain related areas of the brain process information related to self pain and other pain, which suggests that there is only a partial overlap between self and other when processing the pain of others. Reporting pain sensation after observing another in pain would suggest that there is more than just a partial overlap of pain related areas, as pain responders are sharing both emotional and physical pain qualities. In Chapter Three the neural correlates of pain experience generated by the pain of another will be addressed.

Observing pain in others leads to a variety of responses, feelings and behaviours. Goubert, Craig, Vervoort, Morley, et al. (2005) propose a model of pain observation that generates either other oriented distress (empathy/sympathy) or self oriented personal discomfort distress. Most studies have used stimuli depicting a needle into a hand which

has no contextual or social cues, and discussed shared neural regions associated with pain in self and other in terms of empathy for pain. Assuming observing somebody else in pain leads to an experience of empathy may not be a useful model for further understanding of pain responders. A wide variety of scores was recorded, but on average the scores for empathy were fairly low. Some participants laughed, some participants were shocked, and some had neutral facial expressions whilst observing an image of a broken arm. Noting the relatively low state empathy scores reported by both groups, empathy for pain when observing another in pain may not always be the case.

Pain responders report pain being generated automatically after they observe a physical injury, which could suggest that the pain sensation is generated due to extracting the sensory information about pain in a social context, not the unpleasantness associated with the pain (Avenanti et al., 2009). The distinctions between the sensory and affective qualities are difficult to disentangle and are highly correlated with each other in pain generated by noxious physical stimuli (Price, 2000). The division between sensory and emotional components of pain in observation of pain is more marked. Separating the sensory and emotional qualities of observation of pain is useful because the division enables us to break down aspects involved in the pain generated by viewing another in pain.

State empathy is significantly higher in pain responders compared to non pain responders, however it is uncertain as to whether empathy is driving the reports of pain or is a consequence of being in pain. Loggia et al. (2008) demonstrated that a group of high empathisers (induced by an actor talking about the death of his girlfriend) experienced increased pain sensitivity compared to a group of low empathisers (induced by the same actor talking about how he deceived an old lady). The results suggest that

empathic feeling towards another, not empathy for pain per se, generates increased sensitivity for noxious stimuli.

Overall trait measure scores of empathy did not correlate with pain intensity, a finding which has also been demonstrated by Jackson et al. (2005). The IRI categorises types of empathic response into four main categories (described in the method section): the only subscale to reveal a near significant difference between groups was perspective taking. Brain activation linked to somatosensory features of another person in pain has been demonstrated to interact with cognitive empathy or perspective taking (Cheng, Yan, Lee and Decety, 2008).

It is possible that pain responders are more suggestible to feeling pain than most individuals. The following study will address the possibility that pain responders are more suggestible; that is, they feel a sensation of pain because of the suggestion that they will feel pain. Almost ten per cent of participants report pain when asked despite the apparent absence of any physically noxious stimulus or other reason for their pain. These participants presumably respond to the suggestion that they might be in pain in the same way that people will start to scratch if the presence of fleas is indicated (Pennebaker, 1982).

Innocuous stimuli are often rated as more unpleasant when participants expect to feel painful stimuli and this is linked to increased activity in pain related areas such as the anterior cingulate cortex (ACC) and insula (Sawamoto, Honda, Akado, Hannakawa, et al., 2000). High expectancy for suspected analgesic drug efficacy has been found to reduce reports of pain (DePascalis, Chiaradia and Carotenuto, 2002) as well as reducing pain perception in headache patients (Classen, Feingold and Netter, 1983). Suggestion is unlikely to fully explain the reports of pain, because pain responders did not respond to

every image. If pain responders are able to report pain to some images and not to others, then they are most likely responding to the individual features of the images and not to the suggestion of pain posed in the question. Around 30% of participants reported pain, which is much higher than the percentage of participants expected to respond simply because of suggestion.

It is possible that participants were experiencing pain during the experiment, perhaps as a result of a long standing or recent injury, however, participants did not show any behavioural signs of pain or mention it in conversation during the experiment. It is therefore unlikely that participants were experiencing additional pain. However, even if there was a small percentage of the sample that were experiencing pain at the time of the experiment it is unlikely that as the chronic pain alone, was driving the reports of pain.

Pain responders report higher levels of negative emotions when observing images of others. Negative emotions such as fear, unpleasantness and disgust are implicated in the generation of painful sensations in the absence of peripheral input, as demonstrated by Kirwilliam and Derbyshire (2008). Stimuli showing fear, disgust, anger or pain have been shown to increase subjective pain reports (Wunsch, Phillipott, Plaghki, 2003). The link between pain and emotion is further supported by evidence to suggest that emotional distress experienced for another activates limbic areas of the brain, thought to underpin emotional processing, as well as the processing of pain (Eisenberger, Lieberman and Williams, 2003). Negative emotions in general have a decreased effect on pain tolerance, but observing images of bodily injury have been demonstrated to increase pain intensity significantly more than unpleasant stimuli depicting scenes without bodily injury (Godinho, Magnin, Frot, Perchet and Garcia-Larrea, 2006). The bodily injury in the images included in this study, and the subsequent pain sensation associated with the

images, suggest that the painful content of the stimuli is driving the response of pain. However, it is possible that the emotional states induced by the images also influence pain reports, and it is important to control for this. The next experiment will match participants for emotional states induced by the painful images in order to better establish the role of emotion processing and pain reports to pictures. In Chapter Three we will also use images depicting negative emotional stimuli but no bodily injury as well as the images depicting bodily injury to try and delineate factors associated with pain evoked by observation of pain in others.

It is possible that the pain images are judged by the pain responders as more painful, causing increased activation of areas of the pain matrix thought to be implicated in pain processing (Singer et al., 2004). Activation of areas of the pain matrix prior to noxious stimuli is thought to be implicated in increased pain sensitivity to noxious stimuli (Loggia, Bushnell and Mogel, 2008). We will explore whether pain responders judge the actor in the painful stimuli to be in more pain than non responders and subsequently process this type of painful stimulus differently to non pain responders in the following experiment.

2.5 Experiment Two

2.6 Introduction

In Experiment One we discussed how pain responders respond to painful images. In the following study we investigate two factors that may influence reports of pain when observing others in pain: memory for pain and judgements of pain in others.

2.6.1 Pain Judgements

Pain is commonly appraised as a warning of bodily damage or threat to the self (Crombez, Eccleston, Baeyens and Eelen, 1998). There is a considerable degree of variation in pain experiences generated by a single noxious stimulus. There are many proposed reasons to explain differences in pain perception; for example, pain experience can be mediated by the perceived threat value of the stimulus. Perceived threat or pain value is likely influenced by the predisposition in some individuals to pay greater attention to a painful stimulus. Increased attention towards noxious stimuli is thought to increase pain experience, in the same way as lack of attention towards the painful stimuli decreases pain experience (Crombez, Eccleston, Baeyens and Eelen, 1996a; Miron, Duncan and Bushnell, 1989). Recent research has also reported varied judgements on the pain of others, e.g. Hadjistavropoulos and Craig (2002) state that perceiving pain in others is influenced by contextual, psychological and behavioural factors (Sullivan, Thorn, Haythornthwaite, Keefe, et al., 2001).

Individuals who perceive an unrealistic threat (e.g. catastrophisers or individuals who are hypervigilant), are more likely to overestimate the pain of others compared to individuals who score low on these constructs (Martel, Thibault, Roy, Catchlove et al., 2008). Over-exposure to patients expressing pain likely leads to an underestimation of their pain (Prkachin, Soloman, Hwang and Mercer, 2001) and has also been linked to reduced brain activity in somatosensory cortex (Cheng et al., 2008; Decety, Yang and Cheng, 2010) responsible for processing intensity and location of the stimuli (Price, 2000). Increased perceived intensity of pain in others has been found to be linked to decreases in motor preparation, a marker of coding the visual pain properties in others (Avenanti et al., 2005; 2006). Given the link between judgements of pain intensity and physical changes linked to processing the pain of

others, it may be the case that perceived pain intensity in others influences the reports of pain in others.

Reporting pain to an image of another in pain is very unusual and has only been recently reported in a small proportion of phantom limb patients (Fitzgibbon et al., 2010) and by a significant minority of participants in the initial pilot study. The unique example of pain without injury generated by another in pain raises a question as to how pain responders perceive pain in others. It is possible that pain responders overestimate the pain of others in comparison to those who do not report pain when they observe another in pain. Images of others in pain may be inherently more painful for pain responders than non pain responders which in turn may have an effect on pain sensation.

2.6.2 Memory for painful events and observation of pain

Memory for painful events is adaptive; remembering the pain of touching something hot prevents us from repeating the same action, in turn avoiding injury (Flor, 2000). Whilst it is critical we learn to predict and avoid painful stimuli, memory for pain is likely to influence future pain experiences (Jantsch, Gawlitza, Geber, Baumgartner et al., 2009). In some cases memory of past traumatic painful events can spontaneously trigger pain. Whalley, Farmer and Brewin, (2007) report the incidence of painful flashbacks in the victim of the 7/7 London bomb attacks. Salomons, Osterman, Gagliese and Katz (2004) also report the incidence of two patients who, years after experiencing an episode of awareness during analgesia, experienced pain flashbacks similar to the pain felt during the period of consciousness. Salomons et al. (2004) stated that the pain flashbacks were

triggered by visual stimuli similar to that involved in the original surgery. Fitzgibbon et al. (2010) also reported cases of phantom limb patients who reported pain sensations in their phantom when they observed another person in pain. The pain is said to resemble pain felt in the limb prior to amputation. The ability to empathise with another's pain has been linked to past experiences of pain (Preston and de Wall, 2002). It is possible that pain responders report pain as a result of a reactivation of pain memory directly linked to the pain content in the picture.

2.7 Method

2.7.1 Design

A one way between-participants ANOVA was performed for group (pain responders, non pain responders and emotional responders) on each of the items included in the questionnaire such as level of discomfort and intensity of the pain judgements made by the participants.

In order to assess the association between the frequency of painful memories and reports of pain, a Pearsons chi square was performed on yes/no responses to whether participants had experienced a similar type of pain depicted in the image and yes/no responses to whether they felt pain when viewing that picture.

2.7.2 Participants

Nineteen female pain responders (Mean age =20.3, SD= 1.2), 20 female non pain responders, (Mean age, 20.1, SD = 1.1) (low emotion) and 13 female non pain responders (19.8, SD= 0.7) (matched with pain responders for emotional judgements of the images), with no history of psychiatric illness, were recruited from an undergraduate psychology

course. The non pain responders were classified as emotional responders (non responders who reported no experience of pain) if they scored the same or above as pain responders on the three key emotions; disgust, sadness and fear. Matching the pain responders and a subset of non responders attempted to control for the role of emotions when observing others in pain. Participants gave informed consent and were debriefed after taking part in the study. All participants were free from neurological or psychological disorder.

2.7.3 Procedure

The procedure from experiment one was repeated with the inclusion of one new image and three new questions. Each image was displayed for six seconds, after which participants were asked to fill out questionnaires as per the procedure 2.2.3. In addition, participants were asked “how much pain do you perceive the individual in the image to be in?” and “how much general discomfort did you feel when observing the images?” In order to assess the issue of response expectancy linked to the self report in the questionnaire, an image of a healthy, uninjured, hand was included in the experiment. Participants were asked to rate the image in the same way that they rated the painful pictures. The inclusion of an uninjured hand is used to investigate the question whether the suggestion of pain can generate a pain response to an image that does not possess painful qualities. Participants were also asked if they had experienced the same type of pain depicted in the images, to investigate whether pain memories may play a role in the generation of pain evoked by others in pain.

2.8 Results

2.8.1 Pain Reports

Nineteen out of 53 participants reported pain to at least one image when viewing images of others in pain. The average pain intensity was 2.3. The mean number of images that elicited pain was 1.9. The pain descriptors are depicted in figure 2.4 below.

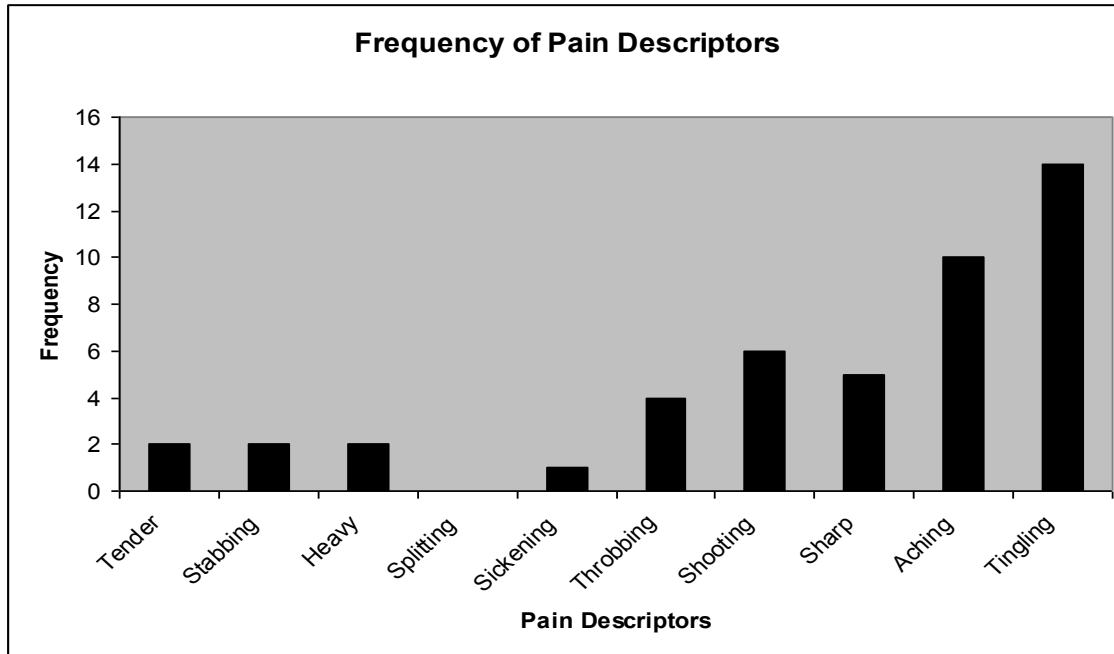

Figure 2.4 Frequency of pain descriptors reported by the pain responders

2.8.2 Pain Judgments

A one-way ANOVA was performed on all of the dependent variables (pain judgements, unpleasantness, discomfort, sadness, disgust, fear and empathy) to assess differences between the three groups. Pain judgement was the only dependent variable that was not significant ($F(2, 52) = 0.9, p = 0.40$ ns.) There was a significant main effect of group for discomfort ratings ($F(2, 52) = 14.5, p < 0.001$), unpleasantness ratings ($F(2, 52) = 14.5, p < 0.001$), sadness ratings ($F(2, 52) = 4.2, p = 0.01$), disgust ratings ($F(2, 52) = 33.2, p < 0.001$), fear ratings ($F(2, 52) = 24.3, p < 0.001$) and empathy ratings ($F(2, 52) = 3.8, p = 0.03$) (see figure 2.5).

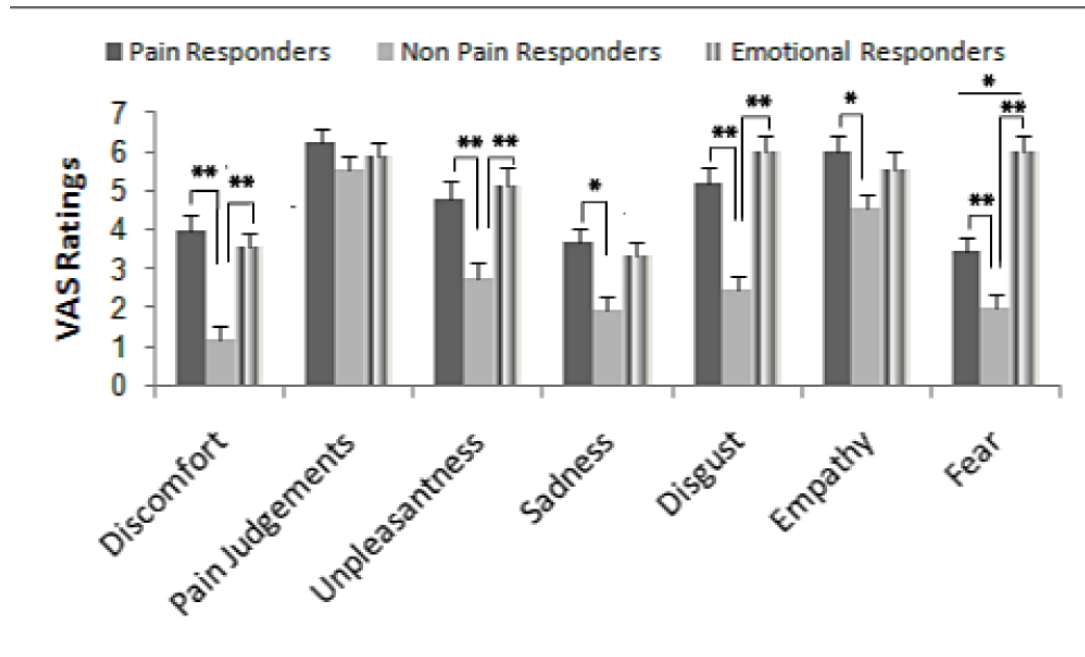

Figure 2.5: Pain responders and emotional responders reported higher ratings compared with non responders on all measures except pain judgements. Asterisks indicate significant differences (* $p < 0.05$, ** $p < 0.001$) and error bars show standard errors.

Post hoc tests (Bonferroni corrected $p < 0.05$) reveal pain responders reported significantly higher ratings compared with non responders for discomfort ($p < 0.001$), empathy ($p < 0.05$), sadness ($p < 0.05$), disgust ($p < 0.001$), unpleasantness ($p < 0.001$) and fear ($p < 0.001$) (see figure 2.4). Emotional responders also reported significantly higher ratings compared with non responders on discomfort, ($p < 0.001$), fear ($p < 0.001$), unpleasantness ($p < 0.001$) and disgust ($p < 0.001$). There was no difference between scores for non responders and pain responders across all measures ($p > 0.05$) except for fear. Emotional responders reported significantly more fear than non responders ($p < 0.001$). Emotional responders reported higher ratings for sadness and empathy although the differences were not significant compared to non responders (sadness, $p = 0.09$, empathy, $p = .22$)

2.8.3 Response Expectancy

In order to investigate the relationship between individual response expectancy and pain, a Pearson's chi square analysis was carried out using the reported frequency of pain reports when viewing healthy images for each group. Six pain responders judged the non-painful hand to be painful compared to 6 non-pain responders matched for emotion and three non-pain responders. The number of participants who perceived pain when observing the healthy hand did not differ by group $\chi^2 (2, N = 55) = 2.9, p = .20$.

2.8.3 Pain Memories

Figure 2.5 illustrates that pain responders report more specific pain memories when observing images depicting painful scenarios than both control groups; the association between memory and group was significant ($\chi^2 (2) = 8.2, p < 0.01$).

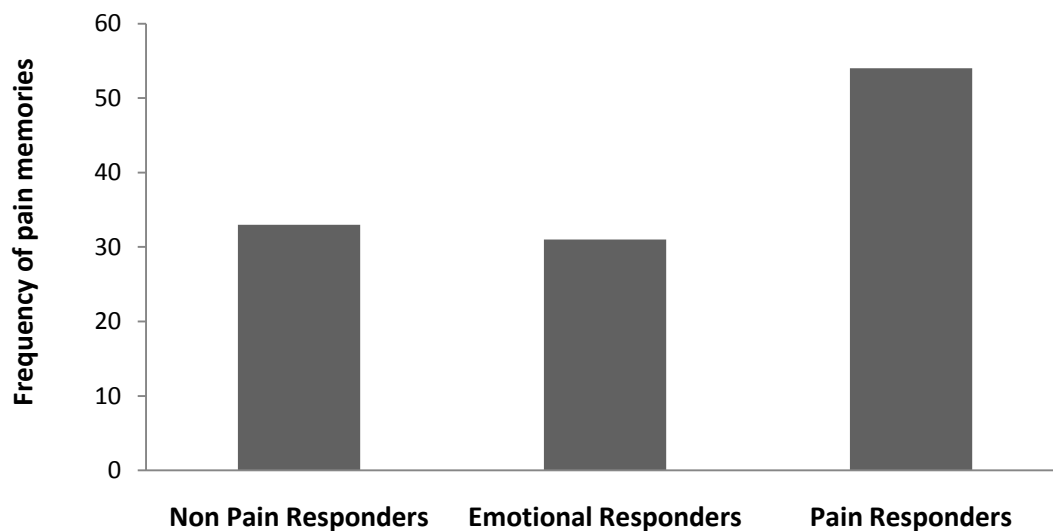

Figure 2.6: The number of pain memories reported by pain responders is higher than both control groups.

In order to investigate the relationship between individual pain memories and pain, a Pearson's chi square analysis was carried out using the reported frequency of pain reports

(pain responders only) and pain memories for the painful images. The association between pain report and pain memories was significant ($\chi^2 (1) = 49.3, p < 0.001$).

Table 2.1: Total count and percentage of pain responders who reported pain and painful memories (left), total count and percentage of pain responders who reported a painful memory and also reported pain.

		Memory				Pain	
		Yes	No			Yes	No
Pain	Yes	25 (71.4%)	10 (28.6%)	Memory	Yes	25 (61.0%)	16 (39.0%)
	No	16 (12.8%)	109(87.2%)		No	10 (8.4%)	109(91.6%)

Table 2.1 illustrates that there were more pain reports from pain responders who had simultaneously reported a painful memory compared to those who had not reported painful memories. There were more painful memories in those who had reported pain compared to those who had not reported pain.

2.9 Discussion

In this experiment we demonstrated that pain is reported after observing others in pain. This replication of Experiment One provides further evidence to suggest that pain generated by observation of another in pain is a robust phenomenon. Pain responders did not perceive the painful images to be more painful than both non pain responder groups, suggesting that pain responders perceive or process painful stimuli similar to the two control groups. Despite perceiving an equally painful stimulus, some participants reported physical sensations of pain. Extracting the sensory qualities of another’s pain is essential to understanding and resonating with another’s pain (Avenanti, 2007) but may be less important in the generation of pain evoked by the observation of others. Knowing or ascribing pain to a model may be very different to automatically resonating

or feeling what it is like for another to be in pain. Reporting more emotion in response to another in pain may be necessary for shared experience but not necessarily for shared pain sensation. Emotional responses generated by observing another in pain are identical in both a subset of non responders and pain responders. Therefore it is unlikely that pain sensation is strongly influenced by the emotional feelings generated by a painful image. Shared somatic representations allow us to share the pain of others through basic sensory mapping (Avenanti, 2007). It would appear that stimulus driven information such as pain intensity is less important for sharing pain of others leading to the generation of pain. Sharing the pain of others likely relies on mechanisms that overlap self and other.

2.9.1 Empathy and Pain Judgements

Individuals who can share the experiences of another are more likely to perceive the event as more painful. The strong correlation between empathy for the model in the picture and the perceived pain experienced by the model is in line with the work of Avenanti et al. (2005), who demonstrated a relationship between the perceived pain felt by the model and suppression in corticospinal excitability. The extent to which motor activity is suppressed during observation of pain is thought to reflect the extent to which the pain is shared by the observer. Cortico-spinal excitability is suppressed during physical noxious stimulation in the same way it is suppressed during observation of pain. Associations between empathic ability and the ability to infer pain in others have been found in previous studies (Danzinger, Prkachin and Willer, 2006). For example although most individuals with a congenital insensitivity to pain (i.e. no personal experience of pain) were poor at predicting others' pain, those with greater empathic ability rated perceived pain in others similar to a group of controls with normal pain experience. The ability to empathise with another is likely to improve accuracy for judging pain in others and bring about an overlap

between self and other. In cases where pain sensation is evoked by observing another in pain, a complete overlap between self and other is achieved. It is possible that personal experiences of pain may influence the extent to which self and other overlap.

2.9.2 Memory and Pain

Support for the idea that personal experiences may influence the report of pain is provided by our second main finding. Here we demonstrate that pain reports are more likely to be accompanied by a pain memory. Painful memories are also more likely to be reported when pain sensation is evoked by an image. It is likely that experience of painful events influence how we perceive the pain in others; for example, individuals who have had very little experience of pain as a result of an insensitivity to pain at birth ascribed a lower pain rating when observing another in pain than controls with normal responses to external noxious stimuli (Danzinger, Prkachin and Willer, 2006). Presumably personal experiences of pain and, in turn, somatic representations of that pain, result in less understanding of the pain and lower pain ratings. It is possible that pain responders are better at empathic processing or sharing another's experience, not because they are other oriented (putting themselves in the shoes of another), but because their own past experiences are re-activated by the sight of another in pain. The images may act as a trigger for re-activation of past pain experiences in the same way that reliving traumatic events in therapy has been found to elicit pain sensation (Whalley et al., 2007). In the only other case of pain generated by observing others in pain, Guimara and Bradshaw (2008) reported that a small group of phantom limb pain patients experience pain that is very similar to pain they have experienced previously, always induced by watching or listening to talk about a pain experience. Reports of pain in the case of phantom limb patients are linked to past experiences of pain. The research discussing pain memories outlines cases

where pain has occurred under very unusual, traumatic and stressful experiences, often a symptom of post traumatic stress disorder (PTSD). PTSD is an anxious psychological state that can arise after exposure to trauma (e.g. war, terrorist attacks, sexual abuse) and is particularly characterised by flashbacks to the traumatic event (Jones and Wessely, 2003). It is unlikely that images of fairly common painful events such as leg breaks, injections and/or bruises would be inherently traumatic in the same way as more severe or stressful life events. However it is possible that observing somebody break their leg or hit their head would result in feeling that pain in the same way that observing sad events can aid recall to personally sad events. It is plausible that more experience of pain increases attention towards pain related stimuli. Chronic headache sufferers, for example, exhibit more attention to images depicting headache compared to healthy controls (Schoth and Lioffi, 2010). The current literature on cortical reorganisation suggests that experience with pain likely strengthens representations of pain in chronic pain sufferers (Flor, 2003).

It is possible that pain memories or pain experiences may strengthen or make painful information more salient. When we observe another person in pain, mirror representations of that pain are more readily accessed. Related to the mirror system specifically, short term memory traces via observation of movement have been demonstrated (Stefan, Cohen, Duque, Mazzochio and Celnik, et al., 2005) to influence self produced movement. For example, a thirty minute observation of movement produced memory representations similar to representation produced by physical practice of movement. It is plausible that a similar mechanism might underpin representations of pain evoked by observation of others in pain.

2.9.3 Response Expectancy

Finally, pain responders were just as likely to attribute the same levels of pain intensity to an image of a healthy hand as non responders. The negligible difference in pain judgements between pain responders and non responders provides some evidence to suggest that the pain reports are not influenced by suggestion or expectancy of pain. Pain responders were not more likely to rate an image as painful when the images depicted a healthy hand. However it is hard to directly compare pain responders with non responders because non pain responders do not report pain. It is possible that pain reports are influenced by a more automatic expectancy of pain in response to observing another in pain, in the same way that the expectation of noxious stimuli can generate pain sensation (Fisher et al., 1995; Schweiger and Parducci, 1982). If participants reported pain because of response bias then it is likely that participants would have discriminated between the different images. Participants only reported pain to a select few images, therefore it is likely that participants were reporting pain in response to the salient painful features of the image and not because of a particular response bias.

2.10 Experiment Three

2.11 Introduction

In Experiment One, pain responders demonstrated no differences compared with non pain responders in reporting somatic or physical symptoms. Here we investigate more general anomalous experiences generated in the absence of physical input. Reports of pain not linked to noxious stimuli are difficult to categorise and understand. Most perceptual experiences are tied to particular physical properties e.g. sound waves are linked to hearing, puncturing of the skin to pain sensation, sodium ions to the taste of saltiness, etc.

When sensations occur without the presence of a physical stimulus, they are often referred to as hallucinatory or anomalous experiences. Without the presence of an obvious cause, pain is commonly labelled as 'psychosomatic'. The term psychosomatic is often used to describe pain sensations thought to originate psychologically or from the mind, with no accompanying physical problem.

Bodily sensations, distortion of body shape and time, changes in sensory intensity and verbal hallucinations are all categorised as anomalous perceptions on the Cardiff Anomalous Perceptions Scale (CAPS) (Bell, Halligan and Ellis, 2006). Anomalous perceptions which include hearing voices, sensing the presence of someone when no one is there, and the occurrence of burning or other unusual sensations are examples of symptoms displayed in psychosis and other mental disorders (Bell et al., 2006). The concept of a continuum for psychosis, as opposed to psychosis as a discrete entity, has led to an interest in the prevalence of symptoms typically associated with psychosis in the general population. Using the CAPS scale, Bell et al. (2006) found that 11.3% of a large non clinical sample reported experiencing a higher incidence of perceptual anomalies than a clinical sample. Other perceptual anomalies, such as visual, olfactory or gustatory hallucinations, are also reported in a small percentage of the general population (Johns, Nazroo, Bebbington and Kuipers, 2002; Ohayon, 2000). Whilst there has been some attempt to look at individual differences, mainly focusing on trait empathy and past experience, there has been little focus on how the individual comes to report pain. The prevalence of unusual sensory distortions in the general population raises the question of whether pain generated by the observation of another in pain is symptomatic of a more general distorted perceptual processing.

2.12 Method

2.12.1 Participants

Ten (mean age 19, SD: 0.5) pain responders and twelve (mean age 18.8, SD: 0.8) non pain responders who had taken part in the initial pilot study were invited to take part in a questionnaire based study. All participants were debriefed following completion of the questionnaire.

2.12.2 Procedure and scale

2.11.2.1 Cardiff Anomalous Perceptions Scale (CAPS)

The CAPS scale is a 32 item questionnaire devised to assess anomalous experiences in the general population, validated with a large non-clinical sample (see appendix four). The cronbach's alpha is 0.87. The items relate to three different categories of perceptual anomalies which are temporal lobe experience, chemosensation and first rank symptoms of psychosis. Temporal lobe experience is a blanket term for unusual experiences frequently described after temporal lobe epileptic seizures and not specifically related to psychosis

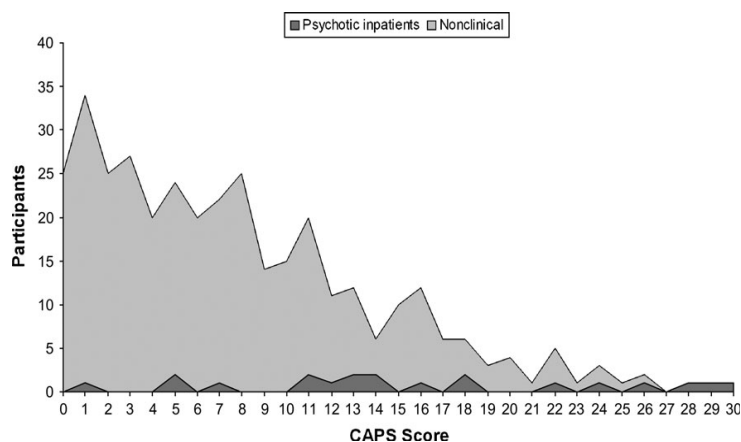

Figure 2.6: reproduced from Bell et al., 2006 showing distribution of CAPS scores in both a control and clinical sample.

(Bell et al., 2006; Gloor, 1990). In fact, some of the perceptual anomalies experienced during temporal lobe seizures are also found in the general population (Persinger and Makarec, 1987). Experiences range from distortions in time perception, feelings of familiarity and hallucinations of music and sounds (Gloor, 1990). Items on the questionnaire associated with temporal lobe disturbance include “do you ever find your experience of time changes dramatically?” and “do you sense the presence of another being, despite being able to see any evidence?” Chemosensation refers to olfactory and gustatory hallucinations, which, compared to visual hallucination, are relatively uncommon in psychosis. Experiencing tastes and smells that are not actually there are the most common hallucinatory experiences to occur in the general population (Ohayan, 2000). Examples of items related to chemosensation are “do you ever notice that food or drink has an unusual taste?” and “do you ever experience unexplained tastes in your mouth?” The final component of the questionnaire assesses unambiguous markers of schizophrenia known as first rank symptoms (Peralta and Cuesta, 1990). Items relating to this component are “do you ever see things that other people cannot?” and “do you hear your own thoughts repeated or echoed?” The scale is answered using yes or no to each of the 32 events (0 low and 32 high) and then expands to ask to what extent each of the anomalous experiences are distracting and distressing, and the frequency at which they occur. Distress, distraction and frequency are marked out of five for each item, resulting in a total possible overall scale score of 180.

2.13 Results

2.13.1 Overall CAPS score

Figure 2.7 shows that pain responders reported significantly more perceptually anomalous experiences than non pain responders ($t(18) = 3.9, p < 0.001$). Pain responders reported more symptoms on the CAPS total score and also reported elevated scores for the extent to which those symptoms were distracting ($t(18), 3.7, p < 0.005$) and disturbing ($t(18), 3.9, p < 0.005$) as well as to how often they occurred ($t(18), 3.2, p < 0.005$).

The most common symptoms reported were sensing the presence of another being despite being unable to see any evidence, having increased skin sensitivity to touch, heat and cold compared to normal and being aware of odours that other people are not aware of. Nine out of ten pain responders reported the above symptoms for each item. Figure 2.7 also provides more information on how the three most common perceptual anomalies were experienced. Although we were unable to statistically compare the results from Bell et al.'s (2006) study it is clear that all pain responders report more occurrences of anomalous experiences than the average number of symptoms aggregated from a group of over 300 controls.

Table 2.2 The range of responses on all four measures on CAPS for pain responders and non pain responders. Brackets show the average range reported by a sample of 337 healthy controls reported in Bell et al. (2006).

	Range for Pain Responders (average as per Bell et al.2006)	Range for Non Pain Responders (average as per Bell et al.2006)
Distraction	11-49 (0-77)	1-21 (0-77)
Disturbance	12-63(0-88)	1-22 (0-88)
Frequency	10-69 (0-88)	1-19 (0-88)
Total CAPS Score	7-21 (0-26)	1-11 (0-26)

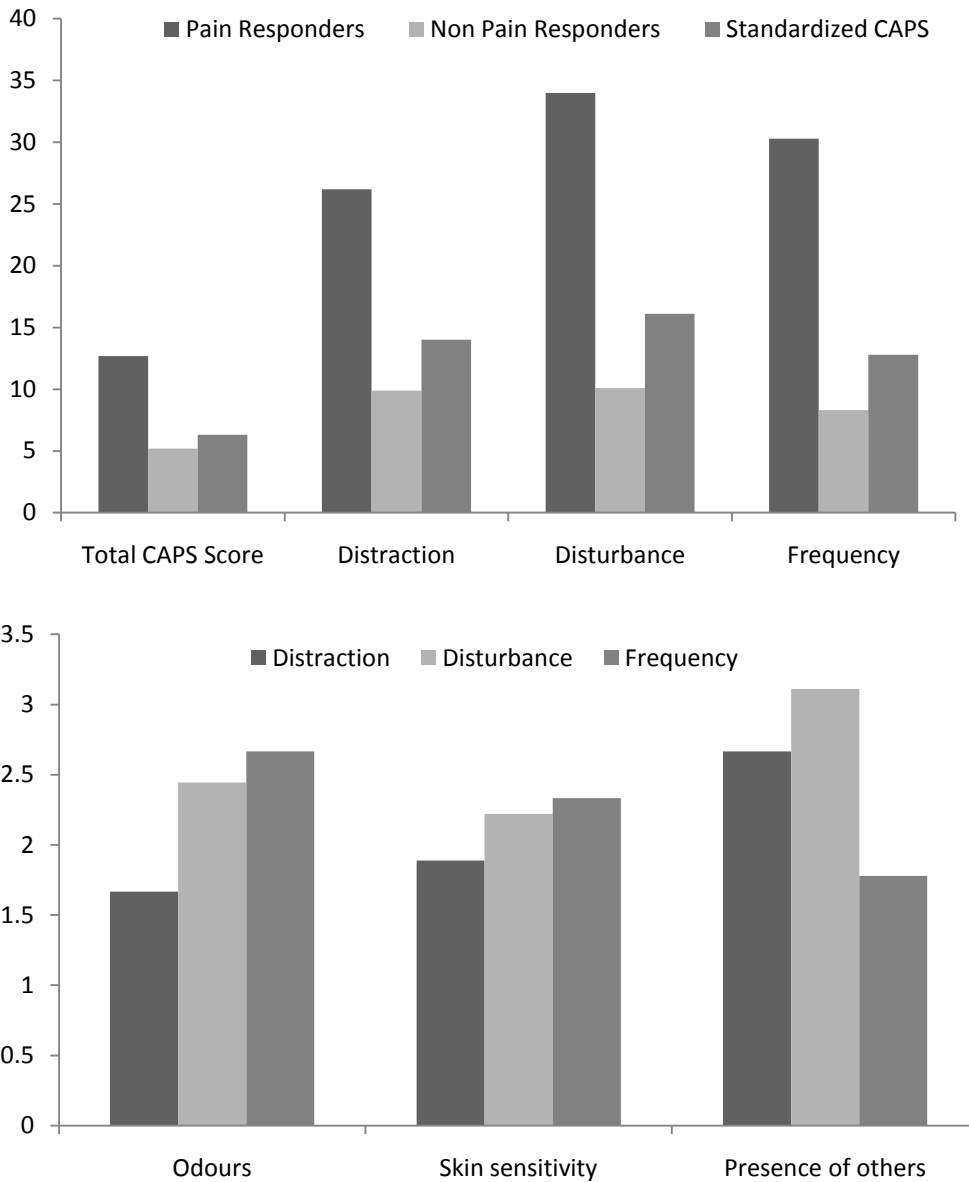

Figure 2.7: The mean score for anomalous experiences reported (max score 32), how distracting participants found the anomalous experiences (max score 180), how disturbing participants found the anomalous experiences (max score 180) and how frequently they occurred (max score 180).

2.13.3 Pain sensation and CAPS

Due to the large differences in overall CAPS scores between pain responders and non pain responders further statistical analysis was performed in order to assess the

Table 2.3: *The correlation between the frequency of pain reports and total number of CAPS anomalous experiences.*

	Distress	Distract	Frequency	Total CAPS
Frequency of Pain	0.085	0.41	0.53	0.64*

*p≤0.05)

relationship between pain responders and CAPS scores.

A two tailed Pearson coefficient correlation was computed to assess the relationship between the number of images that evoked pain and the total score on CAPS. A higher total CAPS score was associated with higher frequency of pain reports. There was significant positive correlation between the two variables ($r = 0.6$, $n = 10$, $p = 0.04$), illustrated in table 2.3.

2.13 Discussion

Here we demonstrate that perceptual anomalies are significantly more common in pain responders than non pain responders. The most common perceptual anomalies were feeling the presence of another person, smelling odours that were not noticed by another and heightened skin sensitivity, experiences not related to pain sensation per se. In an earlier study we demonstrated that somatic symptoms were very similar across groups. While ratings of physical symptoms are comparable to a group of non pain responders, CAPS scores reported by pain responders were twice as high as non responders. This is evidence to suggest that pain generated by observing another in pain is mediated by a general distorted perceptual processing and not distorted pain processing per se. Pain sensations have been described in a very rare cohort of patients diagnosed with schizophrenia, characterised mainly by distorted perceptual processing (Bell et al., 2006;

Bar, Gaser, Nedanic and Sauer, 2002). It is unclear whether the painful somatic hallucinations are triggered by external sources or whether they occur spontaneously. However, the painful symptoms generally lasted for seconds or minutes and consisted of sharp and stabbing pains. A case study demonstrated that painful hallucinations were correlated with primary sensory cortex activity generally responsible for coding the intensity components of pain (Bar, Gaser, Nedanic and Sauer, 2002), in the same way that visual and auditory hallucinations are linked to activation in the respective visual and auditory cortex (Lenox, Park and Medley, 2000; Ffytche, Howard and Brammer, 1998). This report does not suggest that types of anomalous experiences are indicative of psychopathology in pain responders (Brugger, 2002). As many as 11% of individuals from a healthy sample report similar levels of perceptual anomalies as a clinical sample with psychosis (Bell et al., 2006).

The mechanism underpinning pain sensation generated by others in pain is unknown, but there is increasing evidence to suggest that altered integration of multi-sensory information, underpinned by a lack of distinction between self and other may play a role. Patients with visual hallucinations rated no difference in sensations produced by tickling themselves or when they were tickled by someone else, suggesting that self and other generated tickles feel the same. Usually self produced tickles or touches are not felt as ticklish compared to tickles generated by someone else (see review Frith, 1996). Abnormalities in the self monitoring of self produced touch have also been demonstrated in patients with Fibromyalgia, a syndrome characterised by widespread pain of unknown origin (Karst, Meyer, Guedek, Hoy, Borsutsky, 2005). Both fibromyalgia patients and patients with visual hallucinations failed to distinguish between externally and internally generated touch sensations. The similarities in tactile discrimination between self and other generated actions was comparable in patients with Fibromyalgia and Schizophrenia; they

are likely to share similar underlying mechanisms which may be implicated in the generation of pain (McCabe et al., 2005). The inability to discriminate between the sensation produced from being touched and seeing touch also suggests some self/other confusion (Bannisey and Ward, 2007). The discussion of clinical disorders such as Schizophrenia is used as an example of a population who exhibit a high degree of anomalous experiences. It is important to point out that it is the presence of auditory hallucinations and not the diagnosis of 'Schizophrenia' itself that is indicative of deficits in self monitoring (Blakemore et al., 2000). CAPS is a relatively new measure and has only been used in healthy samples (Braithwaite, Sampson, Apperley, Broggia and Hulleman, 2010) and has not been tested with Fibromyalgia patients; as such, the relationship between anomalous experiences and functional pain states is unknown.

The small number of participants included in this questionnaire based study is a limitation; however, the higher than average CAPS scores may tentatively imply that pain responders have distorted perceptual processing possibly related to multisensory integration. The lack of differentiation between self and other produced actions is thought to be underpinned by deficits in self monitoring of intentions illustrated by the feed forward model of action (Frith, 1996). It is possible that observing pain in others blurs the distinction between representations of others pain and self pain. In the next Chapter we will investigate the extent to which self experienced pain and pain evoked by observation of others share common areas of brain activation.

CHAPTER THREE: NEURAL CORRELATES OF PAIN SENSATIONS GENERATED BY
OBSERVATION OF OTHERS PAIN

3.1 Introduction

A series of functional magnetic resonance imaging (fMRI) studies have demonstrated that observing another person in pain, or knowing that a loved one is in pain, can activate brain areas known to process the emotional qualities of pain (Morrison, Lloyd, Pellegrino and Roberts, 2004; Singer, Seymour, O’Doherty, Kaube, Dolan et al., 2004). Brain areas associated with coding the location and intensity of pain, in contrast, are only occasionally reported when observing another person in pain (Jackson, 2006; Lamm et al., 2007). Nevertheless, Lamm et al. (2007) have reported activation of primary (S1) and secondary (S2) somatosensory cortex when asking participants to rate pain intensity when viewing a needle entering a hand. S1 was more strongly activated when participants were specifically asked to evaluate intensity relative to affect. Thus, modulating attention towards others’ experienced pain intensity activates somatosensory areas similar to when subjects orient towards the intensity of a felt pain (Kulkarni et al., 2005).

There is also evidence, however, that observing pain includes a shared sensory component even when attention is not overtly modulated (Avenanti, Buetti, Galati, and Aglioti, 2005; Avenanti, Pauello, Bufalari and Aglioti, 2006; Bufalari, Aprile, Avenanti, Di Russo and Aglioti, 2007). Volunteers observing a needle entering a right hand, for example, had reduced motor evoked potential in their right hand, which indicates appropriate somatomotor preparation following observation of injury (Avenanti et al., 2005; 2006). In a further study, Avenanti et al. (2006) demonstrated a greater reduction in

MEP when subjects observed a needle entering the skin relative to observing pinpricks on the skin. These results demonstrate that somatomotor preparation is modulated by the intensity of the observed stimulus. A series of EEG studies also suggest modulation of somatosensory evoked potentials when observing pain in others (Bufalari et al., 2007, Fan and Han, 2008). Thus there is a growing body of research to suggest that vicarious pain is linked to somatosensory processing, implying that both emotional and sensory components of pain might be shared when viewing another in pain, and pain might be fully experienced because of vicarious observation. No study to date, however, has investigated whether pain sensation is experienced as a direct consequence of viewing another in pain.

3.2 Method

3.2.1 Participants

Participants who reported pain to at least one of the seven images were invited to take part in a further fMRI study. Ten participants (4 male, mean age 27.5) provided consent for this further study. A further ten (4 male, mean age 24.6) participants who had not reported pain to any of the images or clips also provided consent for the fMRI study. Participants were paid £15 for completing the fMRI procedure.

3.2.2 Visual stimuli

Prior to the fMRI study, the seven pain images were matched to seven non-pain emotional images selected from the international affective picture system (Lang, Bradley and Cuthbert, 1999). The images included in the non pain emotion-matched images depicted scenes of war, violence and trauma (e.g. a man holding a gun to another man's head, a scene depicting an army invasion) (see appendix five).

Fourteen new participants were asked to observe the pain images and a series of emotional images and rate each image for emotional qualities (unpleasantness, fear, disgust, sadness). Emotional images that were rated as equivalent to the pain images were selected for use in the fMRI procedure.

3.2.3 fMRI procedure

Brain activation was inferred based on measurement of the blood oxygen level dependent (BOLD) contrast (Ogawa, Lee, Kay and Tank, 1990). These measurements were acquired at 3 Tesla using a Philips system. T2* weighted MR signals were measured using gradient echo-planar imaging (EPI) sequence (repetition time TR = 3000 ms, echo time TE = 2000 ms, FoV = 220 mm, 40 slices, 2.75 isotropic voxels). For each functional run, 215 dynamics were acquired from the AC-PC line. Structural images were acquired using T1T2FE technique (TR=8.4, FoV=232mm, flip angle=60° 288x 288 matrix, 175 slices).

Following acquisition of the structural image, each participant completed two functional runs lasting 643 seconds and then a further series of shorter runs for a separate experiment that will be reported elsewhere. Participants viewed a series of images: (1) images of people experiencing pain; (2) scrambled versions of the pain images; (3) images depicting emotional situations matched for emotional content with the painful images; and (4) images depicting neutral situations matched for content with the painful images. This procedure is illustrated in figure 3.1

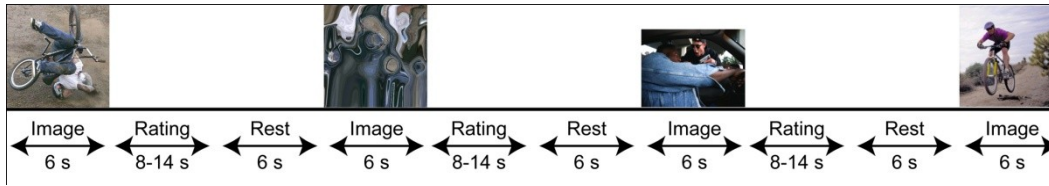

Figure 3.1 Part of a functional run with the 4 image conditions illustrated from left to right: pain image, scrambled pain image, emotional image and neutral image.

The sequence consisted of 28 trials (seven pictures or instructions to imagine in each condition). Each trial consisted of a fixation crosshair (six seconds), followed by one of the four conditions (six seconds) and then a variable period to rate experience (ranging from eight-14 seconds). Order of stimuli presentation was rotated and each set of stimuli was presented once per participant. Immediately after each image, participants were instructed to rate how much pain they experienced and then how unpleasant they found the image or the imagining. Ratings were delivered using a slider connected directly to CHEPS (Medoc, Israel) using the Computerised Visual Analogue Scale (COVAS), which was placed in a comfortable position on the participant. Participants familiarised themselves with the slider in a short practice session prior to scanning. During the practice session the experimenter explained that the start point (left hand side) referred to “no pain” and the end point (right hand side) referred to “worst pain imaginable”. COVAS ratings were recorded online via CHEPS.

3.2.4 Data Analysis

Data analysis was performed using the FMRIB Software Library (FSL release 4.1 - Oxford Centre for Functional Magnetic Resonance Imaging of the Brain), described in detail elsewhere (Smith et al., 2004). In summary, head movement between scans was corrected by aligning all subsequent scans with the first. Each re-aligned set of scans from

every subject was coregistered with his or her own hi-res structural MRI image, with the non-brain components edited out, and reoriented into the standardized anatomical space of the average brain provided by the Montreal Neurological Institute (MNI). To increase the signal to noise ratio and accommodate variability in functional anatomy, each image was smoothed in X, Y and Z dimensions with a Gaussian filter of 6mm (FWHM).

A box-car model with a hemodynamic delay function was fitted to each voxel, generating a statistical image corresponding to condition. Baseline drifts were removed by applying a high-pass filter. Brain regions with a large statistic correspond to structures whose BOLD response shares a substantial amount of variance with the induced changes in the participant's experience. Critically, direct contrast of the brain response during the pain images with that during the emotional images provided an estimate of brain activation during pain experience excluding attendant emotional processing. The multiple comparisons problem of simultaneously assessing all the voxel statistics was addressed via cluster based thresholding. Clusters of voxels that exceeded a Z score >2.3 and $P < 0.05$ (corrected for multiple comparisons) were considered statistically significant. For display purposes, images are thresholded at $Z > 2.3$ and $k > 3$.

3.3 Results

3.3.1 Behavioural Data

Behavioural data collected from the two fMRI groups (responders and non-responders) are shown below in table 3.1.

Table 3.1 Disgust, pain intensity, unpleasantness and state empathy scores for pain responders and non-responders recorded during the behavioural experiment. All ratings were from 0 (nothing experienced) to 10 (maximum pain intensity, unpleasantness or state empathy). Non-responders were selected for their lack of pain experience during observation and no pain was reported by any of the non-responders to any of the images or clips.

	Disgust	Pain Intensity	Unpleasantness	State Empathy
Responders	3.2 (3.2)	2 (2.4)	2.8 (2.9)	5.5 (3.1)
Non-responders	3.7 (3.2)	-	1.3 (2.3)	3.7 (3.0)
	ns p=.30		t = 4.03, (p < 0.01)	t = 4.01, (p < 0.01)

3.3.2 fMRI Experiment

None of the non-responders reported any pain while viewing the images in the scanner, while the responders reported an average of three images as generating definite pain (mean rating 3/10). Contrasting the brain activation when viewing emotional images not depicting injury with those depicting injury should reveal pain related activation only for the subjects reporting vicarious pain. Critically, in subjects who do not report pain, the two images should produce a similar emotional reaction and a similar pattern of activation, resulting in little or no difference when contrasting activation across the conditions. This critical contrast is shown here. In summary, the responders consistently activated the anterior midcingulate cortex (aMCC), anterior insula, prefrontal cortex and S1 and S2 across all contrasts. The nonresponders consistently activated aMCC and prefrontal cortex but did not activate insula, S1 or S2, and occasional deactivation of the insula was observed.

Figure 3.2 illustrates that subjects reporting pain to the images depicting injury activate the ACC (especially the aMCC), insula, S1 and S2 in comparison with emotional (no injury) images, whereas subjects not reporting pain show little activation for the same contrast.

The ROI data were entered into a repeated measures ANOVA to reveal a significant difference between groups for the overall profile of responses in these ROIs ($F_{1,18}=5.0$, $p=0.04$). The interaction of group with region was also significant ($F_{7,126}=4.5$, $p<0.01$). Post hoc t-tests revealed significantly greater responses in the responder group in right insular cortex (R IC), left insular cortex (L IC), right secondary sensory cortex (R S2) and left secondary sensory cortex (L S2).

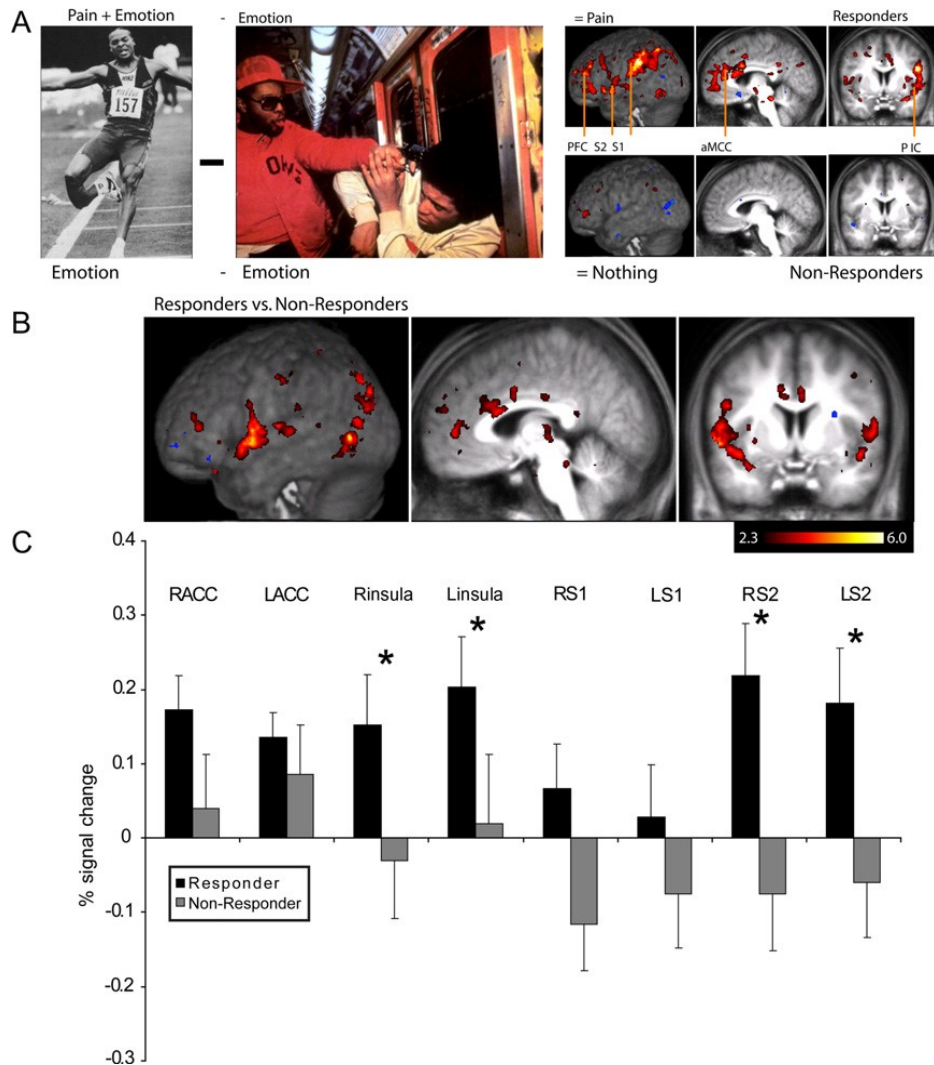

Figure 3.2 Top left (A) illustrates a typical pain image shown to all subjects during fMRI. This image generated pain and emotion in the responders but only emotion in the non-responders. A typical non-pain emotion picture is shown to the right and a pain picture to the left. Subtracting the brain activation during the non-pain emotion images from brain activation during the pain images reveals regions of the pain neuromatrix (labelled) in the responders but not in the non-responders. These differences between the groups are shown below (B) thresholded at $p < 0.01$ (uncorrected) to show the profile of difference. Whole brain analysis demonstrated significantly ($p < 0.05$, corrected) greater activation in the responders versus the non-responders in the left prefrontal cortex (MNI coordinates: -4, 52, 32; $Z(\text{height}) = 5.2$; $k(\text{extent}) = 698$). The results of the ROI analysis are graphed at the bottom (C). Asterisks indicate significant differences ($p < 0.05$) and error bars show standard errors.

Figure label	Responder > Non-Responder			Non-Responder > Responder		
	Brain Area (x, y, z coordinates) (region)	Side	Z-Score	Brain Area (x, y, z coordinates) (region)	Z-Score	
1	Prefrontal Cx (-4, 52, 32) (BA6/9)	L	<u>3.6</u>	No observable difference	-	
	(7, 46, 32) (BA 6/9)	R	2.9	No observable difference	-	
2	S1 (-57, -19, 43)	L	3.0	No observable difference	-	
	(59, -6, 43)	R	2.3	No observable difference	-	
3	S2 (-53, 4, -4)	L	2.9	No observable difference	-	
	(56, -26, 32)	R	2.9	No observable difference	-	
4	aMCC (-5, 10, 33)	L	2.7	No observable difference	-	
	(12, 29, 25)	R	2.1	No observable difference	-	
5	Thalamus (-1, -16, 1)	L	2.6	No observable difference	-	
	(30, 4, 0)	R	3.6	No observable difference	-	
6	Brainstem (-9, -30, -16)		2.8	No observable difference	-	
	(6, -34, -19)		2.4	No observable difference	-	
7	Cerebellum	L				
	No observable difference	L	-	No observable difference	-	
	No observable difference	R	-	No observable difference	-	
8	A. Insula (-45, 2, 1)	L	2.8	No observable difference	-	
	(38, 2, 9)	R	2.6	No observable difference	-	
9	P. Insula (-49, 1, 0)	L	2.8	No observable difference	-	
	(39, 1, 11)	R	3.0	No observable difference	-	
10	Amygdala					
	No observable difference	L	-	No observable difference	-	
	No observable difference	R	-	No observable difference	-	
11	Hippocampus					
	No observable difference	L	-	No observable difference	-	
	No observable difference	R	-	No observable difference	-	

Table 3.2: Group differences for the regions with increasing BOLD response when comparing pain images with emotion images.

3.4 Discussion

Our study provides convincing evidence that a significant minority of normal subjects can share not just the emotional component of an observed injury but also the sensory component. These subjects describe observing at least some injuries as painful, and they activate regions of the brain known to be involved in pain (figure 3.2). Similar to previous work with hypnosis, the current study provides good evidence that these regions are not just passively recording injury or threats to tissue but are actively generating painful experience (Derbyshire, Whalley, Stenger and Oakley, 2004).

Previous responses to observations of non-noxious touch have also produced somatic (S1 or S2) activation, and our findings provide further support for the idea that mirror or empathic responses do not rely exclusively on motor imitation and can involve a shared sensory response (Avenanti et al., 2005; 2006; Banissy and Ward, 2007; Valeriani, Betti, Le Pera, De Armas, Milliucci et al., 2008). Other investigators have also suggested that sources not typically considered noxious can generate pain, and that this experience is physical rather than metaphorical, or purely emotional, in nature (Eisenberg, Lieberman and Williams et al., 2003; MacDonald and Leary, 2005). Thus it is possible that at least some people might experience pain directly, even in a non painful scenario such as when observing another in pain.

This finding was maintained despite extensive questioning of subjects and significant effort to exclude responses restricted to visceral, or general unpleasant, feelings. Pain descriptors provided by the subjects included a high frequency of clearly somatic terms such as stabbing, shooting, sharp and tingling. Supporting these subjective pain reports, brain activation was higher in all areas associated with the pain matrix for those who experienced pain compared with the non-responders who felt no pain. Studies

investigating the neural underpinnings of empathy have also generated activation in regions of the pain matrix (Singer et al., 2004; Jackson et al., 2005). In these studies, activation of the ACC and the insula was found when subjects viewed or anticipated somebody else in a painful situation, but the subjects did not actually report experiencing pain in these studies and sensory areas (S1 and S2) were not activated. There was also no significant correlation between reported pain intensity and empathy or unpleasantness or disgust. A shared emotion with another person in pain is often referred to as an empathic experience, but that experience might be quite different from a shared pain experience. While some people may readily share the emotional perspective of others, that shared empathic experience might have surprisingly little relation to the shared experience of pain intensity demonstrated here. Others have also failed to demonstrate a significant correlation between trait empathy and measures of sensory experience (Jackson, et al., 2005). When S1 activation has previously been reported, the activation was stronger when subjects were specifically asked to focus on the intensity of the observed painful stimuli. A vicarious sensory painful experience, therefore, may be linked to attention and vigilance towards pain rather than to empathy.

Overall, regions associated with the emotional component of pain were activated more strongly and consistently than regions associated with the sensory component. Specifically, activation was observed in the rostral, rather than caudal, regions of ACC. The rostral ACC is linked with the emotional component of pain and with observing pain in others, rather than with pain due to noxious heat or cold (Jackson, Rainville and Decety, 2006; Vogt, Berger and Derbyshire, 2003). Subjects with high state empathy also report higher heat pain experience during noxious somatic stimulation (Loggia, Mogil and Bushnell, 2008). In our experiment, pain responders had significantly increased pain unpleasantness and state empathy. Thus, higher state empathy in our pain responders and a

stronger response to the emotional component of the image may drive a secondary somatic reaction that is felt as pain. On the other hand, although ACC activation was greater in the responders, this difference did not reach criteria for significance in the ROI analysis. It is possible that pain in responders is more dependent on a larger somatosensory response driving a secondary emotional response. Other imaging technologies such as MEG or EEG can formally test this speculation (Fan and Han, 2008).

Here we have focused on the critical analysis comparing pain images with non-pain emotional images. Other contrasts generally support previous findings (Singer et al., 2004; Jackson et al., 2005; Lamm et al., 2007). However we failed to demonstrate insula activation in all contrasts. Previous studies using cartoon depictions have failed to activate the insula, possibly because the subjects failed to see the images as real (Fan and Han, 2008). Our non-responders might also fail to see the images as ‘real’ because of their extreme content, but this speculation will require further investigation to substantiate. It is also possible that the insula codes somato-sensory information (e.g. responsible for coding the location and intensity of pain experience).

The precise nature of the individual differences driving pain experience in the responders remains open to further investigation. Previous studies have reported variability in pain empathy dependent on trait-cognitive empathy and personal distress (Avenanti et al., 2005), self-centred versus other-centred stance (Jackson et al., 2006), feelings of exclusion (Eisenberg et al., 2003) and catastrophising (Sullivan et al., 2006). Studies are ongoing in our laboratory to investigate whether responders can more readily adopt the perspective of the other and more readily incorporate a prosthetic limb into their body, results of which will be reported in Chapters Five and Six. We note that perspective taking did trend very close to significance in this study and that this difference and others might

be revealed as significant when using larger samples. A further possibility is that certain features of the images, such as the presence of a facial grimace (Saarela, Hlushchuk, Williams, Schurmann, Kalso et al., 2006) or a particular type or intensity of injury, contribute to the pain experience.

The responder group did not respond with pain to every image and different images elicited pain across our responders. If future studies can identify the features of an image most likely to yield a pain response then it could be instructive to compare pain evoking versus non-pain evoking injury images. The current study demonstrates a considerable activation difference between responders and non-responders and the clearest behavioural correlate with that activation difference is the report of pain for at least some of the images. It remains uncertain whether there is a qualitative or quantitative difference when responders view injury images and report pain versus viewing injury images and not reporting pain. Our speculation is that the difference is quantitative (there is a threshold of some sort that responders are able to tip over) but we need further studies to substantiate that claim.

Regardless of the precise mechanism of vicarious pain experience, our findings add to a body of evidence that pain can be experienced without injury. Our results go substantially further than previously, however, by directly associating the tendency to report a somatic noxious experience, when observing another in pain, with activation in both emotional and somatic regions of the brain. Such findings have important implications for our understanding of sensory experience in general and for pain in particular. Observation of pain directly generating pain, for example, could form part of the aetiology of functional pain. By increasing the understanding of pain without injury we might develop better insight into the mechanisms and causes of functional pain.

As similar areas of the pain matrix are activated for vicarious and physical pain, the perception action model of empathy is often used to explain the neural correlates of empathy (Preston and De Waal, 2002). This model states that there is a representation of the action that is directly shared and drives the shared experience. A smile, for example, provides information about the happy state of the person observed and, through motor mimicry, leads to a shared happy state. Our results, however, provide little support for a motor representation of pain. Observation of the subjects did not indicate any overt grimacing or bracing action and the fMRI results provided little indication of motor preparation or response. Nevertheless, other studies have demonstrated motor preparation using more sophisticated behavioural and TMS techniques (Avenanti et al., 2005; Bufalari et al., 2007). In the following Chapter we investigate overt motor responses in pain responders.

CHAPTER 4: OVERT MOTOR RESPONSES NOT MODULATED BY PAIN GENERATED
VIA OBSERVATION OF ANOTHER IN PAIN

4.1 Introduction

The pain system and motor system are very tightly linked (Sailer, Molnar, Cunic and Chen, 2002). A sudden sharp pain produced by stepping onto a tack, for example, will cause a reflex withdrawal of the affected leg (to prevent further damage) and a reflex stiffening of the other leg (to prevent the person falling over). These responses occur before any pain is consciously experienced to facilitate rapid escape from dangerous stimuli. Once pain enters conscious experience the need for further escape measures may become apparent. Conscious pain experience and volitional motor systems are also linked to promote survival by facilitating the avoidance of dangerous stimuli.

The connection between pain and the cortical motor system is more complex than the activation of a spinal reflex. During painful experience both premotor and motor regions are activated to coordinate the preparation to withdraw and actual withdrawal (Sailer et al., 2002). Stimulation of the motor cortex, however, can also inhibit the transmission of noxious information in spinal pain pathways (Yeziarski, Gerhart, Schrock and Willis, 1983), which suggests that the motor system influences somatosensory experience as well as motor responses to stimulation (Peyron, Laurent and Garcia-Larrea, 2001).

Further evidence that somatosensation and motor activity interact comes from studies demonstrating that noxious events can inhibit motor responses. Corticospinal motor

evoked potentials (MEPs) are inhibited during painful injection of hypertonic saline (Le Pera et al., 2001) and a reduction in corticospinal excitability is often associated with reduced motor preparation (Duque et al., 2005). Kofler et al. (1998) also demonstrated that pain administered to the finger tips reduces motor neuron excitability (in the hand) but also increases motor neuron excitability in the biceps brachii (bicep). It is possible that a decrease in motor preparation at the site of damage might prevent further damage to the affected limb whereas an increase in motor preparation in an adjacent limb facilitates defensive reactions.

There is evidence that the complex relationship between the motor system and pain also exists when observing somebody else in pain (La Pera et al., 2001; Kofler et al., 1995). Avenanti et al. (2005), for example, demonstrated that watching a video of a hand being injected decreases motor evoked potentials (MEPs) compared to watching a cotton bud touch the same hand. Thus observing another person in pain influences somatomotor preparation. The inhibition of the MEPs presumably reduces the potential for movement to limit the possibility of danger to the observer (Leis et al., 2000).

In a later study, Avenanti et al. (2008) again demonstrated that observing an injection reduced the MEPs in the congruent hand but increased the MEPS in the incongruent hand. That is, if participants observed an injection into a right hand the participants' right hand MEPs reduced while their left hand MEPs increased. These findings are analogous to those reported by Kofler et al. (1998) when directly delivering a noxious stimulus and suggest that observing a noxious event results in similar defensive reactions.

The interactions of noxious stimuli and motor preparation are likely to influence reaction times for motor responses. Participants observing an image of a needle puncture,

for example, were quicker to release a key with their congruent hand compared with observing a cotton bud touch a hand (Morrison et al., 2007). The participants were slower, however, to press the key, indicating that observing an injury facilitates avoidance and inhibits approach. These effects were observed 500 ms after viewing the image but were not observed at 100ms. This difference was interpreted as reflecting the influence of top down cognitive or affective processes such as empathy or mechanisms related to empathy discussed in Chapter One. Empathy is the subjective experience that is often associated with observing another in pain but is much more likely to be a conscious, subjective experience than pain recognition. The link between the motor system and empathy is not very well understood, however embodied simulation theory of empathy suggests that representations of others' actions and emotions are coded automatically and potentially provide a platform for empathic experience.

Chapter Two demonstrated that observing another in pain evokes a feeling of pain in approximately one third of normal controls. Chapter Three also demonstrated that pain generated by observation of others is associated by S1 and S2 pain matrix activation. Other studies have also reported the experience of pain evoked by observation of pain in patients with clinical pain (Bradshaw and Guimara, 2008; Bradshaw and Mattingley, 2001). Typically participants report this vicarious pain experience as immediate and automatic, but the precise timing and nature of the experience remains uncertain.

Participants experiencing pain through observation will presumably have similar motor changes to those demonstrated by Kopfler et al. (1998) and Avenanti et al. (2005; 2008). The changes in motor activity might, however, be more exaggerated in participants who respond with a report of physical pain compared with those who do not respond with a report of physical pain. In addition, if the responder pain is dependent upon top down

cognitive or affective processes, then the changes in motor activity might occur at around 500 ms, similar to the changes reported by Morrison et al. (2007). Alternatively, if the responder pain is dependent upon visual information being rapidly integrated into the somatomotor system for pain, then the motor changes might be more rapid. Pain following a nociceptive stimulus typically causes brain activation at around 100 ms (Ploner et al., 2006). Thus, if the visual stimulus acts like a noxious stimulus in pain responders, then the influence of that stimulus should be observed relatively early in pain responders.

Automatic coding of the representations of others could form the basis of pain generated by observing another in pain. As pain is being experienced then motor preparation to move away from the stimulus will be greater or completely inhibited. The automatic sensation of pain is probably due to the short stimulus-response latency of painful information. Painful information is processed in the brain at around 100ms after the application of noxious stimulus (Ploner, Gross, Zimmerman and Schnitzler et al., 2006). If pain generated by an external stimulus is similar to pain evoked by noxious stimuli then there will also be decreased latency compared to non pain responders.

Watching somebody else in pain generates context specific motor responses (Morrison et al. 2007). Thus, it is expected that participants who feel pain when observing another in pain will demonstrate inhibition of motor preparation resulting in slower reaction times when moving towards a picture of injury compared with a neutral picture. This inhibition is also predicted to be greater in responders versus non-responders. Furthermore pain responders may have an earlier inhibitory response compared with non-responders. In order to investigate whether viewing time of painful images modulates the motor response we vary the duration of the image presentation.

Here two experiments are conducted to investigate the approach and withdrawal movements to pain observed in others at after different exposure times.

4.2 Method

4.2.1 Experiment One

4.2.1.1 *Participants*

Twenty two right handed participants (mean age = 19.5, $SD = 0.6$, range 18-25) provided informed consent and took part in the study in exchange for course credit. Participants were categorised as pain responders if they reported pain after observing another in pain during pre-testing using the procedure described in Chapter Two. This resulted in 10 pain responders and 12 non pain responders. Three participants were excluded for making errors exceeding 15%. All procedures were performed in accordance with local ethical regulations.

4.2.1.2 *Procedure*

Participants were asked to take part in a Go/No Go reaction time paradigm while sitting one metre away from a standard computer screen. Participants were asked to rest their index finger on the space bar and were told to begin responding by either pressing or releasing the space bar when they viewed an image of another person's hand. They were asked to either rest their finger in order to press or they were told to hold down the space bar in preparation for releasing the key. Participants viewed three types of image: 1) images that depicted needles appearing to penetrate locations on the hand ('needle'

images); 2) needles that were covered by a plastic cover touching locations on the hand and fingers ('touch' images); and 3) images that displayed an individual hand ('hand' images). All images were presented in third person perspective (see figure 4.1).

Participants were presented with a fixation cross, followed by a screen displaying an orange or purple square. After the orange or purple square, an image was displayed. As soon as the image appeared participants were required to make a response. Their response was made by pressing down or releasing the space bar with their index finger. A correct response was a press or release in trials when participants observed an orange screen (Go trials). A response was not required in trials when participants observed a purple screen (No/Go trials). The maximum time given to respond was 2000ms. Half the participants started by pressing down on the space bar (key release) and the other half started the experiment by resting their right index finger on the space bar (key press). Each experiment consisted of 180 trials divided into 2 blocks. The experiment lasted approximately 30 minutes.

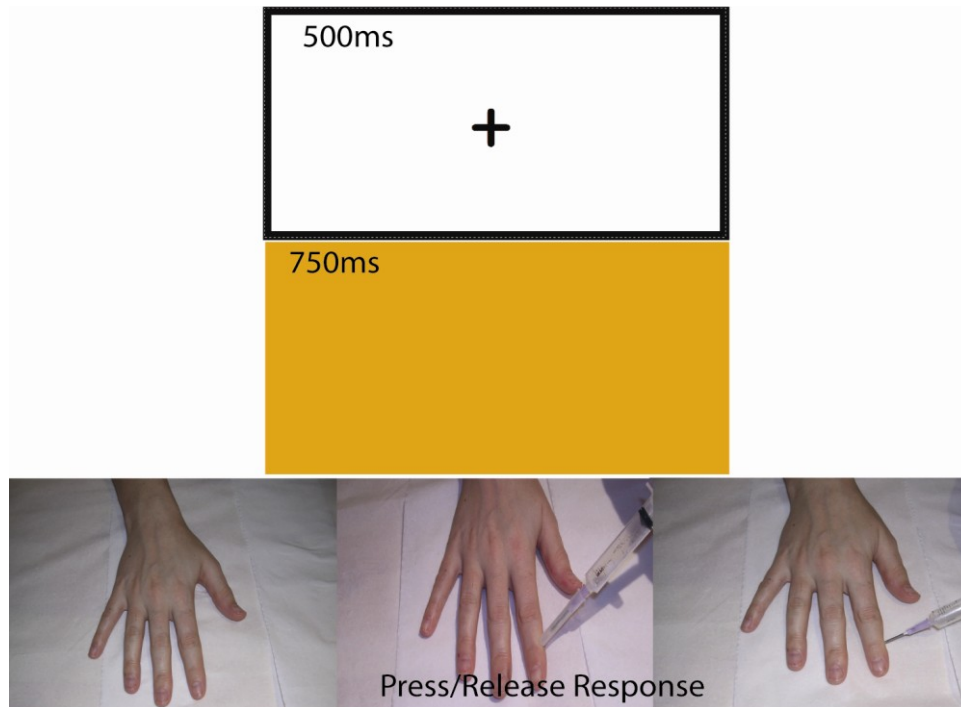

Figure 4.1: *The experimental procedure for Experiment 1 and the three different types of stimuli. Right to left: 1) Hand presented without any stimuli 2) Touch stimuli (needle covered with a plastic top, touching the index finger 3) Painful stimuli (needle appearing as if it is piercing the index finger). Participants were instructed to press or release the space bar when viewing the image.*

4.2.2 Experiment Two

4.2.2.1 Participants

Twenty two healthy participants (4 male) (age range 18-23) from the university of Birmingham provided informed consent. Participants were categorised as pain responders if they reported pain after observing another in pain during pre-testing using the procedure described in Chapter Two. This resulted in ten pain responders and twelve non pain responders. All participants took part in the study in exchange for course credit.

4.2.2.2 Procedure

We adjusted the experiment to investigate the time course of the image presentation and its effect on motor responses. We presented the images for either 500ms or 1000ms. Participants sat one metre away from a standard computer screen and were asked to rest their index finger on the space bar. The order of the Go/No Go reaction time paradigm used in Experiment One was adapted to investigate the viewing time of the image (see figure 4.2) The participants were informed that they should begin responding by either pressing or releasing the space bar when they viewed an image of another person's hand.

Each participant was asked to either rest their finger in order to press or to hold down the space bar in preparation for releasing the key. They were presented with a fixation cross for 500 ms followed by a screen displaying the image for either 500ms or 1000ms (for a description of images see figure 4.2). A purple or orange screen then appeared, on presentation of the purple screen (No/Go trials) participants were instructed to inhibit their response i.e. no response was required. When the orange screen appeared (Go trials) all press or release responses were required as soon as the images were displayed. There were 360 trials in total presented in 3 (120 trials per block) separate blocks. Each block contained 80% 'go' trials. The experiment lasted for 45 minutes in total.

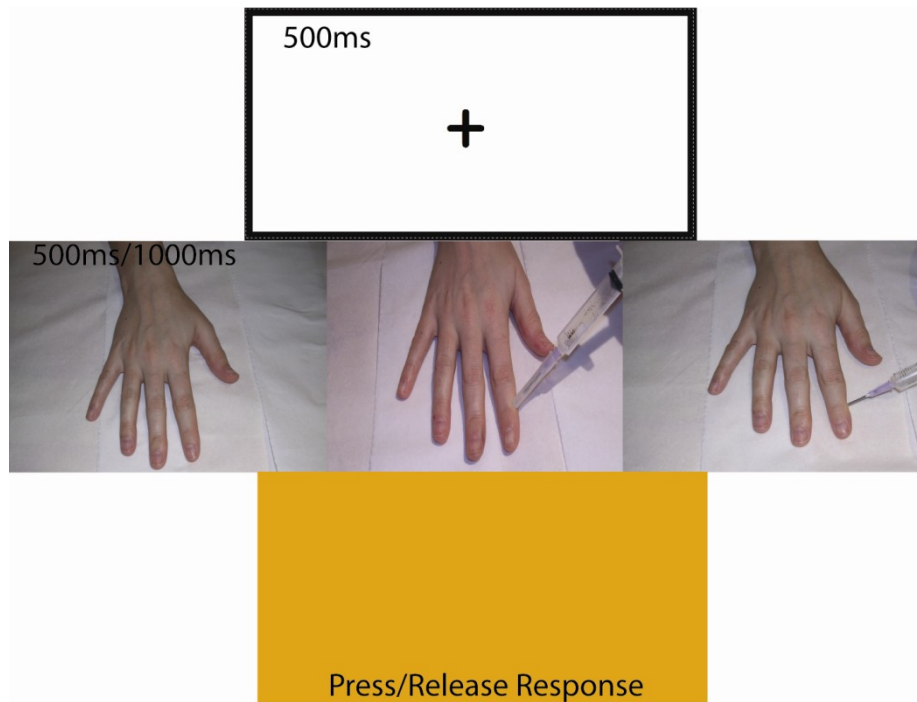

Figure 4.2 The experimental procedure for Experiment 2 and the three different types of stimuli identical to Experiment 1. Right to left: 1) Hand presented without any stimuli 2) Touch stimuli (needle covered with a plastic top, touching the index finger 3) Painful stimuli (needle appearing as if it is piercing the index finger).

4.3.1 Experiment One

A mixed effects 2 (action, press/release) x 3 (image, “pain”, “touch”, “hand”) x 2 (group, non pain responders, pain responders) ANOVA was performed to investigate the differences in correct reaction times across groups and conditions.

Overall, participants were slower to perform approach movements (key presses) ($M = 533\text{ms}$) than withdrawal movement (key releases) ($M = 511\text{ms}$). There was a significant main effect of action ($F(1, 40) = 4.5, p < 0.05$). Participants also took longer to respond after viewing an image of a needle compared to images of a needle touching a hand or an image of a healthy hand ($M_s = 524\text{ms}, 476\text{ms}$ and 566ms respectively). There was a main effect of image ($F(1, 40) = 28.2, p < 0.001$). Post hoc (bonferroni corrected, p

<0.05) t-tests revealed that there was a significant difference between images of a needle touching a hand (“pain” condition), images of a capped needle touching a hand ($p < 0.05$) and a healthy hand ($p < 0.05$). There was also a significant difference between images of a healthy hand ($p < 0.05$) and a capped needle (“touch”) condition ($p < 0.05$). There was no difference in overall reaction times between pain responders ($M = 531\text{ms}$) and non pain responders ($M=515\text{ms}$), as such, there was no main effect of group ($F(1, 20) = 3.4, p = 0.07$).

The interaction between group and action was significant ($F(1, 20) = 11.2, p < 0.05$). Post hoc paired t-tests revealed that pain responders were significantly slower to make key presses than key releases ($t(20) = 2.7, p < 0.05$) but there was little difference between reaction times for key releases compared to key presses for non pain responders ($t(20) = -1.0, p = 0.28$) (see fig 4.3).

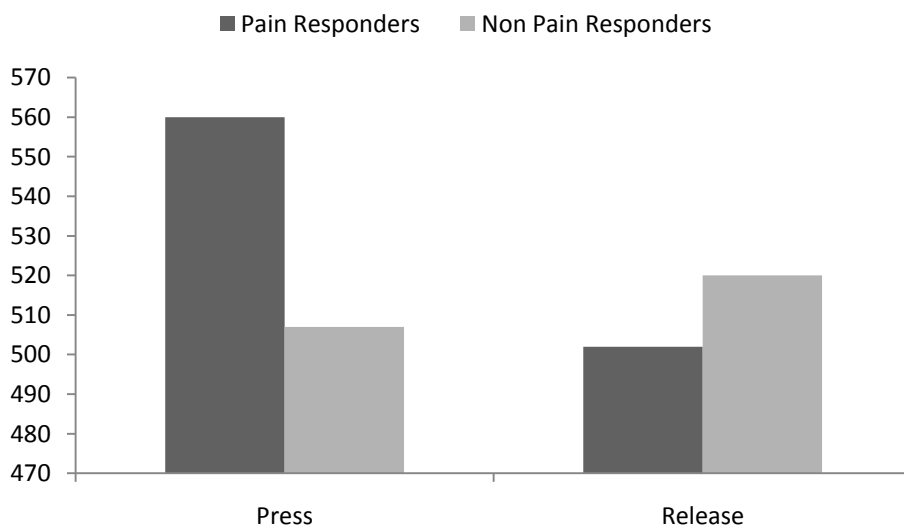

Figure 4.3 shows reaction times for key presses and releases as a function of group.

The interaction between group and image was significant ($F(2, 40) = 5.2, p < 0.05$) (see fig 4.4). Post hoc independent samples t-tests revealed that pain responders were significantly slower to respond after viewing an image of a capped needle touching a hand than non pain responders ($t(20) = 4.1, p < 0.01$). There was no significant difference in reaction times between groups after viewing an image of a healthy hand ($t(20) = -0.89, p = 0.4$) or when viewing a painful image ($t(20) = 1.7, p = 0.08$).

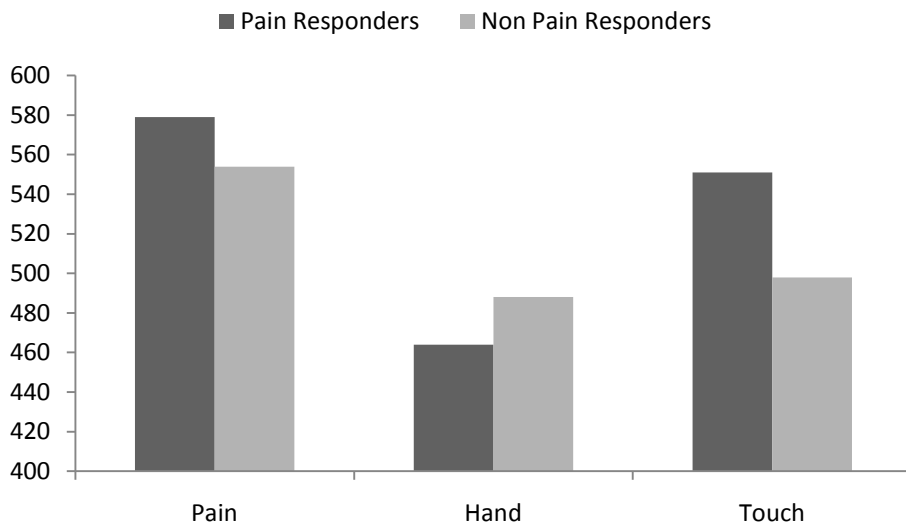

Figure 4.4 shows reaction times for both groups in response to each image collapsed across response.

There was also a significant interaction between action and image ($F(2, 40) = 5.7, p < 0.05$). Independent post hoc t-tests reveal that participants were slower to make key

releases when viewing an image of a healthy hand versus an image of a capped needle (“touch”) ($t(20) = 4.5, p < 0.01$). Participants were slower to make releases after viewing painful images compared to images of a capped needle touching a hand ($t(20) = -7.7, p < 0.01$) and after viewing images of a healthy hand ($t(20) = 9.5, p < 0.001$). There was no significant difference for key presses after viewing “touch” images versus images of a healthy hand ($t(20) = 1.2, p = 0.28$) and painful images ($t(20) = -0.53, p = 0.59$). There was no significant difference between images of a healthy hand and painful images also when making key presses ($t(20) = -1.6, p = 0.1$) (see fig. 4.5)

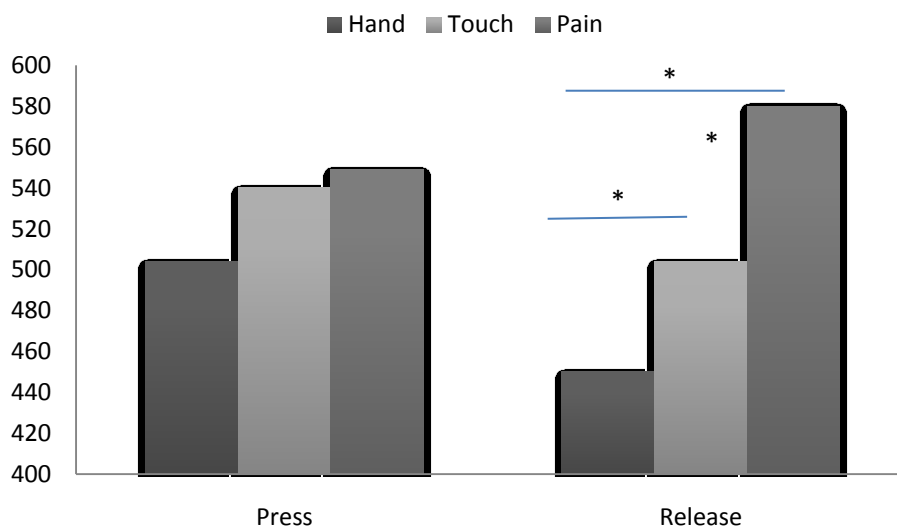

Figure 4.5 shows reaction times after viewing each image type as a function of key press (Press/Release).

4.3.2 Experiment Two

In order to investigate the effects of viewing time on key responses we adjusted the experiment to investigate the time course of the image presentation and its effect on motor responses. We presented the images for either 500ms or 1000ms. The correct mean

response times were processed in into an ANOVA using a 3 (image – “needle”, “touch” or “hand”) x 2, (motor response – press or release) x 2 (group – pain responders or non-responders) x 2 (time- 500ms/1000ms) mixed factorial design.

Participants took longer to make a key press (either press or release) after viewing a painful image ($M=547\text{ms}$), relative to an image of a capped needle touching a hand ($M=480\text{ms}$) and a healthy hand ($M=526\text{ms}$). There was a main effect of image ($F(1, 20) = 7.4$, $p < 0.01$). Post hoc (bonferroni corrected, $p < 0.05$) t-tests revealed there was a significant difference between painful images and images with a capped needle touching a hand ($p < 0.05$) but not between painful images and images of healthy hands ($p=0.28$). There was difference between reaction times when the images was presented for either 500ms ($M=523\text{ms}$) or 1000ms ($M=512\text{ms}$), subsequently there was no significant effect of time ($F(1, 20) .46$, $p < 0.001$). Participants were faster to make key releases ($M=476\text{ms}$) versus key presses ($M=559\text{ms}$), as such there was a main effect of response ($F(1, 20) = 10.3$, $p < 0.05$).

There was a significant three way interaction of image, time and response ($F(1, 20) = 4.2$, $p < 0.005$). In order to look more closely at the three way interaction of image, time and response two separate ANOVA analyses were carried out on each response (press/release).

Participants were slower to make releases after viewing painful images ($M=509\text{ms}$) relative to a capped needle touching a hand ($M=433\text{ms}$) and images of healthy hands ($M=486\text{ms}$), there was a significant main effect for image ($F(2, 38) = 3.4$, $p < 0.05$). Post hoc (bonferroni corrected, $p < 0.05$) t-tests revealed a significant difference as participants took longer to make key releases after viewing a painful image versus a capped needle ($p < 0.05$) but not a healthy hand ($p = 0.46$). Participants took longer to make

key releases after viewing a healthy hand relative to an image of a capped needle touching a hand, this difference was significant ($p < 0.05$). There was no interaction of image and time ($F(2, 38) = 1.1, p = 0.34$).

Participants were slower to make key presses after they viewed a painful image relative to a capped needle and a healthy hand, there was a significant main effect of image ($F(2, 38) = 5.1, p < 0.05$). There was a significant interaction of image and time ($F(2, 38) = 5.1, p < 0.01$). The means are presented in figure 4.6 below. Participants were quicker to respond after exposure to an image of a capped needle touching a hand, after exposure for 500ms, compared with 1000ms, this difference was significant ($t(19) = 3.4, p < 0.01$). There was no significant difference in reaction times for key presses when participants viewed body parts (healthy hand) at 500ms or 1000ms ($t(19) = -0.06, p = 0.5$). Participants took longer to make key presses after viewing a painful image for 1000ms compared to 500ms, subsequently there was a trend towards significance ($t(19) = -1.9, p < 0.06$).

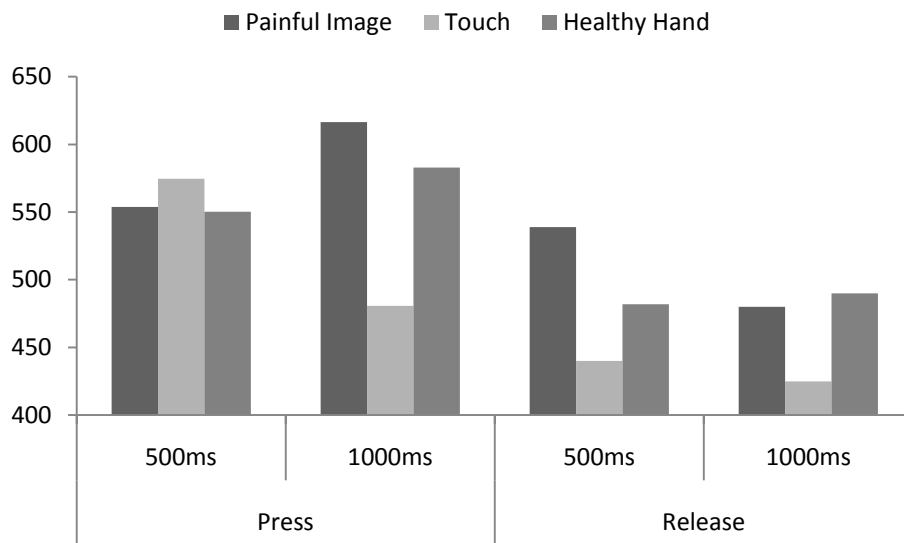

Figure 4.6 shows the mean reaction times for each image either presented for 500ms or 1000ms.

There was no difference in response patterns for pain responders compared with non pain responders and there were no other significant interactions.

4.4 Discussion

The first goal of this experiment was to investigate motor responses in participants who report pain (pain responders) when they see an image of another person in pain. Reaction times were slower during approach and faster during withdrawal in pain responders, but as a consequence of viewing an image of a capped needle ‘touch’ condition, not a needle touching the skin ‘pain’ condition. This result was contrary to the response specific effect on pain responders that we predicted, i.e. slower approach movements and faster withdrawal movements when a noxious event is observed versus a

non noxious event. Pain responders did not get response specific effects produced by inherently painful images immediately after viewing the painful images but did so for tactile stimuli.

The response specific effects for tactile stimuli, relative to painful stimuli, is unexpected given that touch images depicted a needle covered by a plastic cap. Pushing the plastic cap against the skin is not inherently painful and is quite different to a needle being pushed against the skin, which is inherently painful. Response specific effects have been found to occur with painful stimuli, not touch or innocuous stimuli (Morrison et al., 2007). Pain responders reported that the images depicting a needle touching the skin generated a sensation of pain on their hands, therefore it is unlikely that the 'pain' images are not perceived as painful. It is possible that observing a capped needle is a novel image for most participants. The novel nature of the stimulus coupled with the short viewing time could mean that the image was perceived as ambiguous or as an unusual stimulus. It is possible that an ambiguous or novel stimulus is likely to be more threatening than a painful stimulus. For example stimuli depicting threat (e.g. guns, knives, etc.) have also been found to facilitate action (Flykt, 2006), reflected by faster reaction times after viewing pictures of threatening stimuli (snakes/spiders) compared with non threatening stimuli (flowers/mushrooms). We would expect to inhibit motor responses towards the threatening stimuli and this has not been tested other than with painful stimuli. These response specific effects are not present when the images are observed for either 500ms or for 1000ms, which is consistent with threat detection occurring very quickly after stimulus onset (Mogg, Bradley, Miles and Dixon, 2004). Factors such as hypervigilance have been demonstrated to mediate attention towards threat (Weinstein, 1995), and may play a role in the context specific response generated by observing tactile stimuli, although this is purely

speculative. We assume the motor responses are modulated in the pain responders in experiment 4.1 because of hypervigilance to threatening information. Experiment One demonstrates for the first time that pain responders have a context dependent response which diminishes as stimulus duration increases, as a result of viewing non-noxious stimuli images, which is inconsistent with previous work by Morrison et al. (2007).

The perception action model of empathy is often used to explain the neural correlates of empathy (Preston and De Waal, 2002). This model states that there is a representation of the action that is directly shared and drives the shared experience. A smile, for example, provides information about the happy state of the person observed and, through motor mimicry, leads to a shared happy state. Our results, however, provide little support for a motor representation of pain. The findings of this study suggest that while pain responders demonstrate motor inhibition, they do not demonstrate more motor preparation compared to non pain responders. It is possible that the pain generated by others in pain is driven not by simulation of others but potentially by a more generic or conceptual mapping between self and other. Pain responders may have a strong preference towards an egocentric perspective and therefore may not simulate the pain of others but alternatively may re-live on their own pain experiences. Chapter Five will address self-other distinction in pain responders.

The second goal of the experiment was to determine whether this modulation of reaction time began after viewing the image for 500ms or only after viewing the image for 1000ms. Both pain responders and non pain responders demonstrated the same pattern of results in Experiment 4.2. Avoidance responses, i.e. slower presses, were observed after viewing images of inserted needles versus images of a capped needle. The avoidance responses are unlikely to be related to the pain generated by images of others in pain

because both groups demonstrated the same responses. It is possible that after so many trials, the pain reported after observing another in pain habituates.

Our speculation of an immediate pain experience similar to that experienced when receiving a noxious needle stimulus directly is not supported by this study. Motor inhibition following observation of pain is demonstrated here and is consistent with a number of studies suggesting an increased inhibition of motor responses. Using TMS, Avenanti et al. (2005; 2006) have demonstrated that pain observation selectively inhibits the relevant muscles of the hand. Motor evoked potential (MEP) amplitude decreases during observation of a needled hand were specific to the body part observed and to the particular muscle observed, compared to observation of a needled tomato or observation of a cotton bud touching a hand. The decreased MEP amplitude during pain observation resembled the response to directly-experienced painful stimuli (Farina et al., 2003; Le Pera et al, 2001). This reduction in MEP supports the idea of a freezing response to limit harm to the affected limb during pain observation.

The results demonstrate that all participants inhibit overt motor responses involving delayed approaches towards a painful image, but that they do not facilitate overt motor responses involving withdrawal from a pain image. Similar to other studies, this experiment demonstrates that motor responses are inhibited (Morrison et al., 2007) by painful information. These results suggest that pain observation, but not pain generated by observing another in pain, can inhibit movement in the affected limb similar to when delivering noxious heat stimuli (La Pera, et al., 2001). This inhibition presumably serves to prevent further injury, as has been discussed in relation to noxious heat (Kopfler et al., 1998).

Inhibition of motor responses towards our noxious images but not away from them is indicative of a lack of facilitation away from the stimuli. The results here might be a more general freezing response to another in pain, however, the relationship between the proximate and distal muscles and their role in inhibition and facilitation remains unclear. Complex interactions between arm and hand muscles have been demonstrated during pain itself (Kopfler, 2004), probably because motor responses to pain are influenced by descending mechanisms of facilitation and inhibition (Milan, 2002). We did not specifically investigate the relationship between hand and arm muscles during observation of pain, but we assume that the distal arm muscles may be overriding motor inhibition in the hand to prevent harm. Facilitating distal arm muscles would speed up the withdrawal of the hand from harmful stimuli (Kofler et al., 1998). In sum, the results here and elsewhere (Morrison et al 2007; Avenanti et al., 2005; 2006) provide evidence for the protective role of motor responses to real or potential pain but are not specific to pain evoked during observation of another in pain.

CHAPTER FIVE: THE ROLE OF VISUAL PERSPECTIVE TAKING IN PAIN WITHOUT
INJURY

5.1 Introduction

In Chapter Two, we demonstrated that around one third of normal controls report pain when they are exposed to images of other people in pain. In Chapter Three we demonstrated that brain activity associated with pain experienced by the self is also activated during observation of another in pain. The mechanism generating this pain experience remains uncertain. One possible component is the ability to rapidly adopt the perspective of the person being observed. Pain responders might automatically orient their self perspective to that of the other and thus more readily share the other's experience. Here we investigate two types of perspective taking: visual perspective taking and spatial perspective taking, to test this possibility.

5.1.1 Visual Perspective Taking

Visual perspective taking refers to the ability to predict what another person sees (Michelon and Zacks, 2006). Increased ability to process information in the 1st person perspective relative to the 3rd person perspective suggest that visual perspective may play a crucial role in the representations of self and the representations of other (Jeanerrod and Anquetil, 2008). Visual perspective taking is usually categorised by two levels. Level one perspective taking refers to the ability to infer what someone can or cannot see. Level two perspective taking refers to the understanding that the same visual scene can be perceived differently by others. Inferring that someone has a different perspective of the world is

broadly defined as mentalising (Hamilton, Brindley and Frith, 2009). Mind reading or mentalising refers to the ability to attribute mental states to others. Aichhorn et al. (2006) demonstrated that temporal parietal junction (TPJ), an area commonly recruited in theory of mind tasks, was also active in visual perspective taking tasks. Aichhorn et al. (2006) suggested that that visual perspective taking and theory of mind tasks recruit similar regions because they both require the ability to recognise that others take a different perspective of the world. Performances in visual perspective taking tasks and mentalising tasks are both impaired in children with autism (Hamilton et al., 2009), a developmental disorder characterised by an inability to relate to others. Successful social interaction requires inferring the visual and mental perspectives of others. The ability to infer what another person can see implies disengaging from the self visual perspective and adopting the visual perspective of another (Samson, Apperley, Braithwaite and Andrews, 2008) and theory of mind (Samson, Apperley, Chaivarino and Humphreys, 2004). Self perspective is considered as a default egocentric bias that is corrected/ inhibited when trying to understand others (Morewedge and Keysar, 2004).

A failure to inhibit own perspective can result in poor performance in visual perspective taking and mentalising tasks (Hamilton et al., 2009; Samson, Apperley, Kathirgamanathan, Humphreys, 2005). Reduced ability to inhibit self perspective has been associated with poorer performance on mentalising tasks (Bailey and Henry, 2008). Epley et al. (2004) demonstrate that self perspective was suppressed more quickly in some participants compared with others, suggesting that some individuals more readily adopt the perspective of others (Epley, Morewedge and Keysar, 2004; Samson, Apperley, Kathirgamanathan, Humphreys, 2005). Support for this view is provided by Tversky and Hard (2009), who asked participants to describe the relationship between objects with or without the presence of another person. Almost half of the participants described the

location of the objects from the others person's visual perspective even when there was no explicit instruction to do so. It is plausible that at least a proportion of people will more naturally adopt another person's perspective. When participants observe others in pain, they are not instructed to take the perspective of another. It is possible that pain responders are able to map more quickly and easily than non-responders and that they are able to map across perspectives more quickly and easily than non-responders. In general, pain responders might have fewer processing constraints from a 1st person to 3rd person perspective relative to non pain responders.

5.1.2 Embodiment and Spatial Perspective Taking

Misattributions of self with other are typically avoided because we occupy an egocentric point of reference with regard to our self, and, an allocentric perspective with regard to others. The obvious difference between an egocentric reference point and an allocentric reference point is a sense of embodiment (Vignemont, 2007). Embodiment refers to "the sense of being localised in one's own body" (Arzy, Thut, Mohr, Mickel et al., 2006) and is fundamental to a sense of self. Embodiment is crucial to spatial perspective taking because mental rotation of the body is thought to enable switching of spatial perspectives (e.g. from egocentric to allocentric) (Kessler and Thomson, 2010). Blanke et al. (2005) used a spatial perspective taking task in which participants had to correctly identify the location of a glove, placed on either the manikin's right or left hand. Half of the manikins were front facing and half of the manikins were back facing. Back facing manikins were in spatial alignment with the participants' bodies; the right and left hands of the manikin were spatially in line with the right and left hands of the participant. In front facing trials, participants' hands and the manikins hands were situated on opposite sides. It took longer to correctly respond if the figure was front facing than back facing, presumably

because extra spatial rotation was required for the front facing figure relative to back facing figures. In general speed of spatial perspective taking ability tends to decrease with the amount of disparity between the egocentric and allocentric spatial location (Zacks and Micheon, 2005). Blanke et al.,(2005) described this type of spatial perspective taking as mental own body imagery and not perspective taking per se. Visual perspective taking tasks and spatial perspective taking tasks rely on different processes. Spatial perspective taking tasks require own body transformation. Own body mental transformation is believed to be self referenced, i.e. we transpose our own spatial coordinates on to another in order to gain information about the location of external body parts. Spatial perspective is not considered a mentalising task, in that it does not require the inference that other people have different perspectives of a visual scene. For example, children with autism have demonstrated impairments on level two visual perspective taking tasks as well as mentalising tasks but show no such impairment on spatial perspective taking compared to typical children (Hamilton et al., 2009). The visual perspective taking task requires the observer to correctly infer another's perspective to correctly infer what another person sees i.e. take another person's perspective, not simply the location of another person. The overlap in both experience of pain demonstrated in Chapter Two and Chapter Three during observation of another in pain, suggests a lack of distinction between self and other. It is possible that pain responders automatically map between self and other and therefore will show less difference in reaction times when taking on another's visual perspective. In order to test this assumption we will use a low level visual perspective taking task to investigate reaction times when adopting the self perspective and the perspective of others.

5.2 Method

5.2.2 Participants

Twenty six participants (3 male; mean: 19; range: 18-21) provided informed consent and took part in the experiment for course credit. Participants were divided into pain responders (n = 10) and non-responders (n = 16).

5.2.3 Visual Perspective taking task

5.2.3.2 Procedure

Participants were invited to take part in a reaction time experiment involving an avatar viewed on a computer screen surrounded by three virtual walls. A female avatar was used for female participants and a male avatar for male participants. At intermittent intervals, 0-3 circles were presented either on the wall facing the avatar or on the wall facing away from the avatar (figure 5.1).

The participant could always see the number of circles. In half of the trials the avatar was observing the same number of dots as the participant such that the avatar's and the participant's perspective were consistent. In the other half of the trials the avatar observed a different number of dots to the participant such that the avatar's and the participant's perspective were inconsistent.

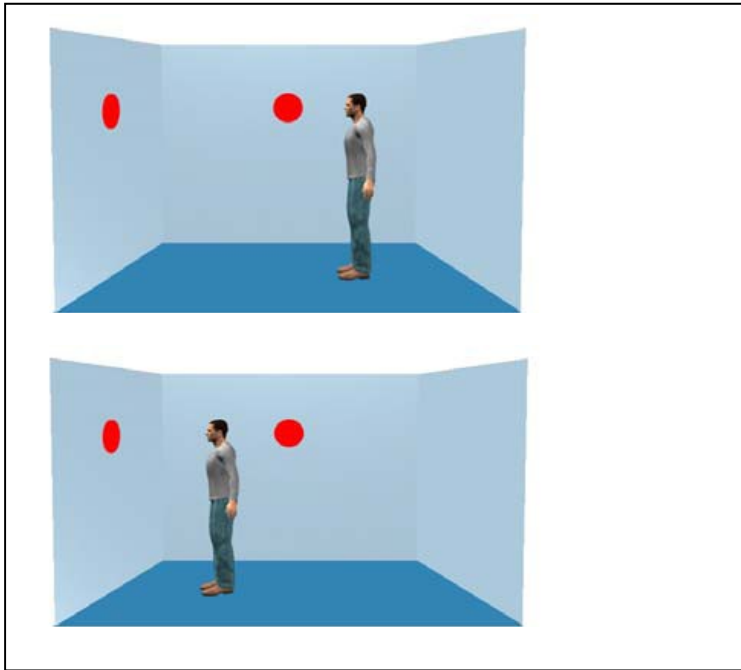

Figure 5.1 Top image shows avatar observing 2 dots, this viewpoint is consistent with the participant's viewpoint. Bottom image shows avatar observing 1 dot, the avatar's perspective is inconsistent with the participant's viewpoint.

Prior to seeing the room, participants were cued to adopt either their own perspective, which was written as “you”, or the perspective of the avatar, which was written as “he” or “she” as appropriate. After viewing the screen for 750 ms, participants were asked to identify the number of circles on the wall from their adopted perspective as quickly as possible. There were 96 trials in total. For half of these trials the participants adopted the perspective of the avatar and for the other half they adopted their own perspective.

Participants identified the number of circles by pressing a button corresponding to the number of circles observed. Participants were asked to comfortably position their fingers on both the mouse buttons at the start of the trial. If participants agreed that the perspective they were told to adopt viewed the same amount of verified dots then participants were asked to press the right button mouse. If participants thought that the perspective and amount of dots to verify were inconsistent they were asked to press the left mouse button.

Time taken to press the button was automatically recorded. Reaction times 2.5 standard deviations outside the mean were removed as outliers.

5.2.4 Spatial perspective taking task

5.3.4.1 Procedure

All participants took part in the own body transformation task adapted from the work of Blanke et al. (2005); the stimuli used are presented in figure 5.2. Participants were required to complete two separate blocks consisting of 96 trials per block (24 of each stimuli). In the main experimental block participants were required to correctly respond to the location of the glove situated either on the right/left hand on the figure (not the screen) (see figure 5.2). Figure 5.2 depicts the front (B and D) and back (A and C) facing manikins used in the experiment. In the lateralisation task (baseline), participants were required to identify which side of the screen the glove was on. Participants responded using the up arrow key for left and the down arrow key for right hand responses. RTs were excluded if they exceeded 2.5 SDs above the mean for each participant. Presentation of all stimuli was counterbalanced.

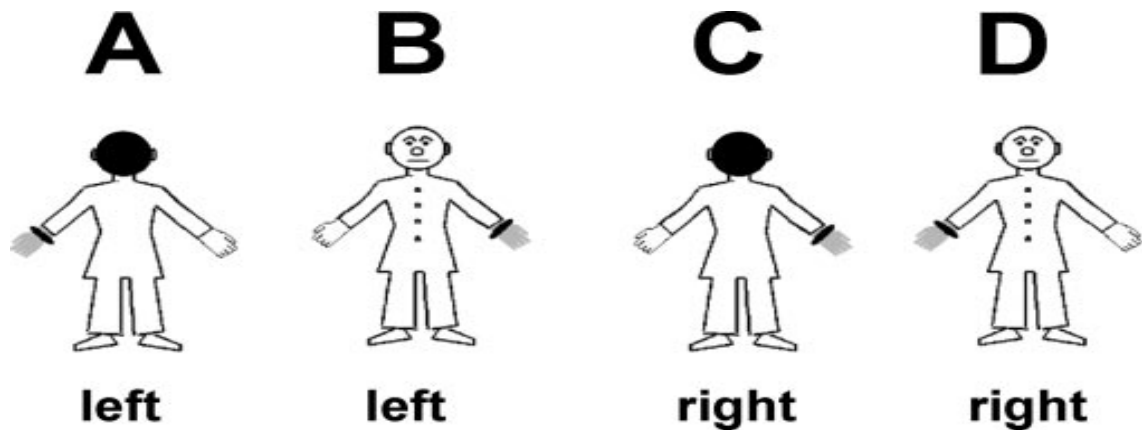

Figure 5.2 The stimuli used in the main experiment adapted from Blanke et al. (2005). Participants are required to state which hand the glove is on. A and C are spatially aligned with participants, therefore no spatial transformation is necessary. B and D require the participant to mentally rotate their body in order to correctly identify the location of the glove. Underneath each figure is the correct response.

5.3 Results

5.3.1 Visual Perspective Taking Task

A 2 (Perspective, Self/Other), x 2 (Consistency, Consistent/Inconsistent) x 2 (Group, Pain responders/Non pain responders) mixed ANOVA design was computed using the correct average reaction times.

Figure 5.3 illustrates overall participants took longer to respond during consistent trials compared with inconsistent trials. There was a significant main effect of consistency ($F(1, 24) = 28.8, p < 0.001$).

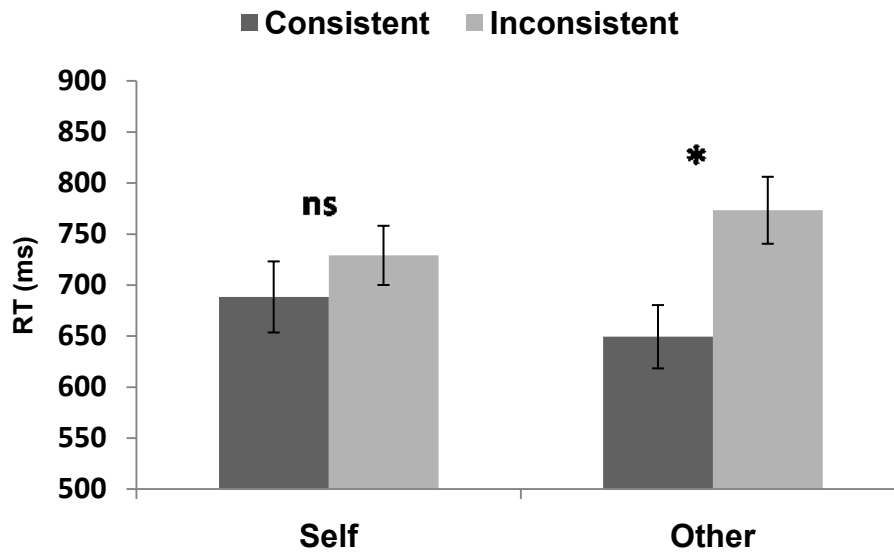

Figure 5.3: Participants took longer to respond during inconsistent trials ($F(1, 24) = 5.3, p = 0.03$). Participants were faster to verify another's perspective during consistent trials relative to inconsistent trials ($F(1, 24) = 49.3, p < 0.001$).

Participants showed no difference in reaction times between self or other perspectives, there was no significant main effect of perspective ($F(1, 24) = 0.04, p = 0.84$). There was a significant interaction effect between consistency and perspective ($F(1, 24) = 12.6, p = 0.002$). There was a trend towards a significant interaction between consistency, perspective and group ($F(1, 24) = 3.6, p = 0.06$). Post hoc t-tests reveal that there was a significant difference between inconsistent and consistent trials when verifying the perspective of the avatar ($t(25), 7.44, p < 0.001$) but not when verifying their own perspective ($t(25), -1.6, p = 0.11$).

In order to look more closely at the pattern of results for each group a separate 2 (Consistency, inconsistency/inconsistency) x 2 (Perspective, self/other) repeated measures ANOVA was performed on reaction times for both pain responders and non pain responders.

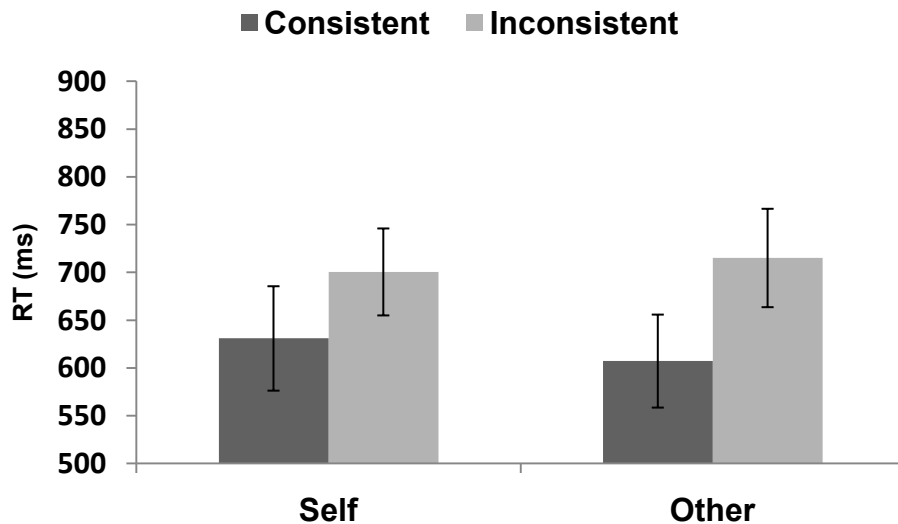

Figure 5.4: shows that pain responders responded more quickly during consistent trials versus inconsistent trials.

Figure 5.4 shows that pain responders were significantly faster during consistent trials compared to inconsistent trials. There was a significant main effect of consistency ($F(1, 9) = 31.1, p < 0.001$). There was no difference in reaction times when verifying self perspective versus other perspective (Perspective ($F(1, 9) = 0.09, p = 0.77$)). There was no significant interaction between consistency and perspective ($F(1, 9) = 2.08, p = 0.18$).

Figure 5.5 shows that non pain responders were significantly faster to respond during consistent trials compared to inconsistent trials. There was a significant main effect of consistency ($F(1, 15) = 11.7, p < 0.004$). There was no difference in reaction times when adopting self or other perspectives (Perspective, $F(1, 15) = .26, p < 0.63$). There was a

significant interaction between consistency and perspective ($F(1, 15), 15.1, p < 0.001$).

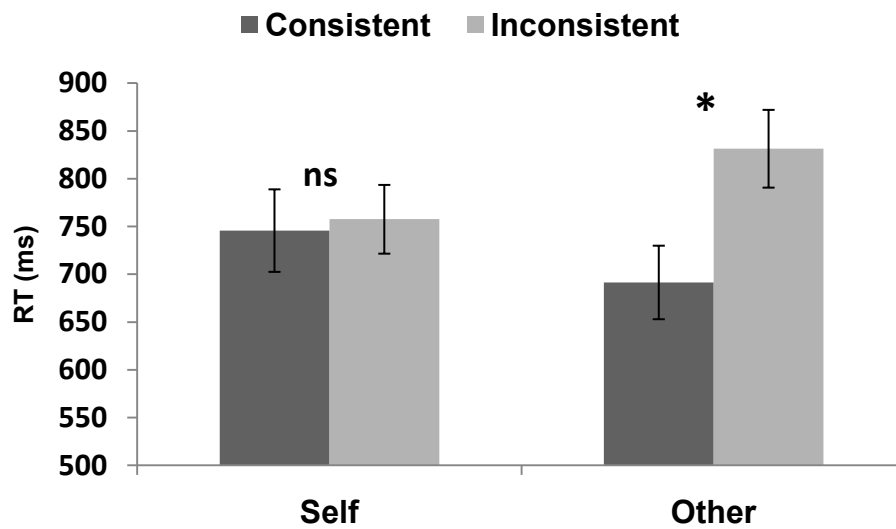

Figure 5.5: Reaction times for non pain responders were faster during consistent trials versus inconsistent trials.

Post hoc paired t tests revealed that the effect of consistency was significant when non responders had to verify the avatars perspective ($t(15) = 5.4, p < 0.001$) but not when they had to verify their own perspective ($t(15) = -0.41, p = 0.69$) (see fig 5.5).

5.4. Discussion

Here we demonstrate that pain responder's show reduced difference in reaction times when adopting their own perspective compared to the avatars. In contrast, non pain responders show marked differences in reaction times when adopting either self or other perspectives. Both pain responders and non pain responders showed the same pattern of responding during the spatial perspective taking tasks. This finding implies that pain

responders are less able to distinguish between self and others' visual perspective in comparison to non responders (Decety and Chaminade, 2003). There are two alternate strategies that may be taking place: either we feel what it is like for someone else to be in pain (like them) or we feel what it is like for us to be in pain (like us) (Decety and Sommerville, 2003; Galinsky, Ku and Wang, 2005). While the former would depend less on self representations of pain and more on 'other' oriented empathic processes, the latter would depend more on 'self' oriented representations of pain and may plausibly be less dependent on 'other' oriented processes. It is also possible that pain responders are not faster to adopt another's perspective, but instead they do not inhibit their own perspective when viewing somebody else.

The visual perspective taking task used here required the participants to make inferences about what another can or cannot see (Newcomb, 1989). Correctly inferring what another can see requires the viewer to inhibit their egocentric viewpoint and adopt the other's visual perspective. This inhibition of egocentric or self viewpoint can also contribute to understanding the thoughts and feelings of others by reducing the influence of the predominant, egocentric, self perspective (Vogeley, Bussfeld, Herrman, Happe, Falkai et al., 2001). Inhibiting the self perspective and adopting another's mental perspective is considered an essential part of empathic understanding (Davis, 1980). Imagining a 'self' perspective while viewing someone in pain, for example, may aid confusion between self and other perspectives (Batson, Lamm and Decety, 2007).

Visual perspective taking does not necessarily require any inference regarding the mental state of the other (Aichorn et al., 2006; Newcomb, 1989). Inferring the mental state of another and then sharing that state, as is the case with empathy, may involve subjectively adopting the cognitive perspective of the other to understand what he or she is thinking. There is a distinction between the ability to shift visual perspective, which is a

low level skill, and the ability to empathise by thinking what someone else is thinking or feeling what someone else is feeling. Presumably lower level skills, including automatic visual perspective taking, contribute to higher level skills, including empathy (Samson et al., 2006). It is possible that the low level mechanism of visual perspective taking contributes to the emotional experience of empathy for another in pain, which correlates with vicarious sensation of both touch and pain (Bannisse and Ward, 2007; Singer et al., 2004), but that at least some components of empathy remain independent of vicarious sensation.

There were no differences in the spatial perspective taking task, presumably because pain responders compared with non pain responders are better at tasks that require mentalising abilities, but not at tasks that require, for instance, mental rotation of body parts per se. In particular, the spatial perspective taking task is a self referenced task

In our previous study (Chapter Two: Experiments 2.1 and 2.2) we demonstrated that pain responders have a high state empathy relative to non-responders. We would suggest that pain responders are generally faster to correctly respond when adopting the visual perspective of the avatar because they are better at disengaging self visual perspective and adopting the other's visual perspective. This disengagement may be more automatic in the pain responders, rapidly reducing the distinction between self and other, and providing a mechanism whereby the pain responders more readily experience pain when observing another in pain. Reducing the distinction between self and other could facilitate the mapping or simulation of bodily representations between self and other. The idea that adopting another perspective is more automatic in some individuals may have bearing on the human mirror system located in the frontal cortex. It is thought that the human mirror system is activated during a first person relative to a third person perspective (Rizzolatti, Fogassi and Gallese, 2001). The faster processing between the perspectives

may underpin the temporary confusion between self and other, which may be underpinned by mirror neurons, which do not distinguish between movements made by the self or other (Tversky and Hard, 2009). We are thus able to represent someone else's actions "as if they were our own" (Ayer, 1963) by the sharing of representations common to action and perception.

Future work will concentrate on performance on higher level mentalising such as inferring the thoughts, feelings and beliefs of others, which are important for the development of empathy (Gallese and Goldman, 1998). Given that pain responders show an automatic propensity towards a blurred self and other distinction, this may have implications for our sense of body ownership. In the next chapter we will use the rubber hand illusion to investigate the sense of body ownership as a potential technique to understand how sensations are mislocated or referred from the observed to the observer.

CHAPTER SIX: ASYNCHRONOUS STROKING DOES NOT DIMINISH SENSE OF OWNERSHIP DURING RUBBER HAND ILLUSION

6.1 Introduction

In Chapter Two we demonstrated that around one third of normal controls will report pain when they are exposed to images of other people in pain. In the previous Chapter we demonstrated that pain responders are able to readily adopt another's visual perspective. Here we investigate the extent to which ownership can be felt over another person's body part. Body ownership refers to the sense of bodily boundary – the sense that my body parts are mine and somebody else's are not (Haggard and Tsakiris, 2005). Bodily ownership is delivered by proprioception and feeling movement from our own body parts, which underpins the sense of ourselves as ourselves and as independent of others.

Physical sensations can only be experienced through our own bodies but, as we have demonstrated in Chapter Two, it is possible to misattribute the sensation of pain simply from visual cues. Capelari, Uribe and Brasil-Neto (2009) used painful-tactile stimuli instead of touch in the rubber hand illusion. They demonstrated that painful visual information was experienced not from the participant's actual hand, but from the rubber hand. The extent to which the purely visual information contributes to the feeling of pain is large; however, visual information about a painful stimulus is likely to be vital for promoting future survival and seems to override an actual painful threat to the participant's actual body part. We do not usually have this sense of ownership and feeling of pain sensations over bodies that are clearly separate to our own. In the case of pain evoked by someone else's injury, however, the boundary between the self and other is unclear. Pain

evoked by someone else's injury presumably involves a misattribution of pain sensation from the location of the observed injury to the same location on the observer.

6.1.1 Rubber Hand Illusion

A way of exploring body ownership is to utilize the rubber hand illusion (RHI). The rubber hand illusion is a common illusory experience in which a subject feels a sense of ownership over a rubber hand (Botvinick and Cohen, 1998). The illusion occurs when the subject's real hand, which is hidden out of view, is stroked in synchrony with a rubber hand placed in full view of the subject. Subjects will usually report feeling the stroking as coming from the rubber hand rather than their own, hidden, hand. This sensation is also typically accompanied by the sense of their hand drifting towards the position of the rubber hand, called proprioceptive drift. The illusion of ownership is thought to come about through a combination of multisensory integration of visual, tactile and proprioceptive information (Haggard and Tsakiris, 2005). The extent to which either visual, tactile or proprioceptive information contributes to a sense of body ownership is unknown, however two main conditions are necessary for successful induction of the rubber hand.

6.1.2 Predefined body map

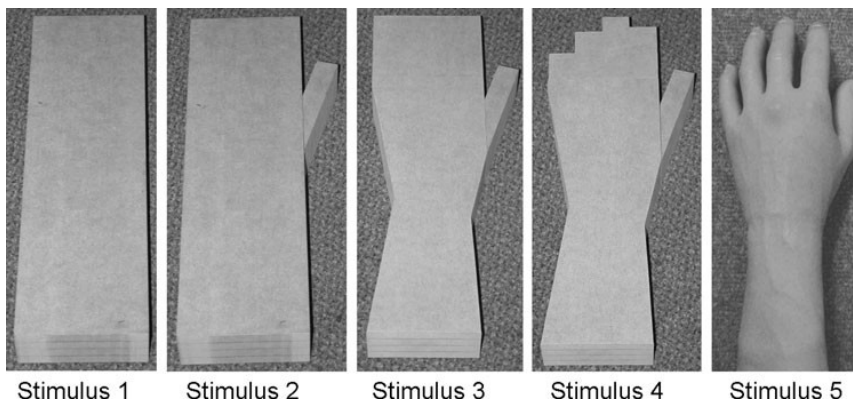

Figure 6.1: The appearance of the wooden blocks, ranging from 1-4 with 4 as most similar in appearance to a human hand, and 5, a prosthetic hand.

The strength of the illusion is typically attenuated when the size and appearance of the rubber hand do not accurately represent

the subject's real hand (Haggard and Tsakiris, 2005; Tsakiris, Carpenter, James and Fotopoulou, 2010). Tsakiris et al. (2010) induced the rubber hand, using five different stimuli ranging from a block of wood to a prosthetic hand (see fig 6.1). Participants only reported a sense of ownership over stimulus five, the stimulus most representing the appearance of a real hand. Presumably the absence of ownership over a non corporeal object suggests that body ownership is influenced by predefined anatomical information. Limited evidence, suggesting that predefined anatomical information is not always necessary for body ownership, has been reported (Armel and Ramachandran, 2003). Armel and Ramachandran (2003) investigated whether any object, in this case a table, could be integrated as part of the body schema. After simultaneous synchronous stroking of the participant's hidden real hand and a table positioned in front of the participant, participants reported feeling touch sensation from the area of the table that was being stroked. Skin conductance responses increased during synchronous stroking of the table compared to asynchronous stroking of the table. The finding of the study by Armel and Ramachandran (2003) supports the view that any object can be incorporated as part of the body, providing that the relationship between the visuo-tactile correlations are strong enough.

6.1.3. Intermodal matching between vision and touch

The illusion is strongest when real and rubber hands are stroked in synchrony; this is because visual-tactile correlations are stronger during synchronous stroking. When hands are stroked in an asynchronous fashion, the illusion is broken or attenuated (Armel and Ramachandran, 2003; Botvinick and Cohen, 1998; Constantini and Haggard, 2007; Tsakiris and Haggard, 2005). Presumably when the tactile information and visual input are out of phase, the rubber hand illusion disappears.

6.1.4 Individual Differences during the RHI

Individuals with schizophrenia report a stronger sense of the RHI in comparison to healthy controls (Peled, Ritsner, Hirschman, Geva and Modai, 2000). The exact mechanism underpinning a stronger sense of the RHI in schizophrenics is unclear, as schizophrenia is a complicated psychological disorder. Moreover, even in the absence of the rubber hand illusion procedure, schizophrenia is partly characterised by somatic delusions, including the disruption of body ownership and agency (McGilchrist and Cutting, 1995). Body image influence is body perception. Mussap and Salton (2006) suggested that participants who were identified as having an unhealthy body image were more susceptible to experiencing the illusion.

6.1.5 RHI and movement

Although the original rubber hand illusion includes only tactile stimulation, there have been many different versions including movement (Drummer, Picot-Annand, Neal and Moore, 2009; Tsakiris and Haggard, 2005). In the motor version of the RHI, movement takes the place of the tactile brush stimulation, usually involving two participants performing a synchronous finger movement. The two participants might, for example, tap their index fingers in time with a metronome. Using movement instead of tactile stimulation introduces the concept of agency. The sense of agency comes from the efferent motor instruction (Tsakiris et al., 2007). Prior to a movement being produced, an intention to generate the movement must be given. The subjective feelings that are associated with the intention and actual movement are referred to as agency. Synchronous active movement of a participant's hand and a rubber hand produced a robust illusion of ownership over the rubber hand (Drummer et al., 2009; Tsakiris, Phrabu and Haggard, 2006). Asynchronous active movement tended to attenuate the strength of the illusion,

similar to asynchronous stroking (Drummer et al., 2009; Tsakaris, Phrabu and Haggard, 2006).

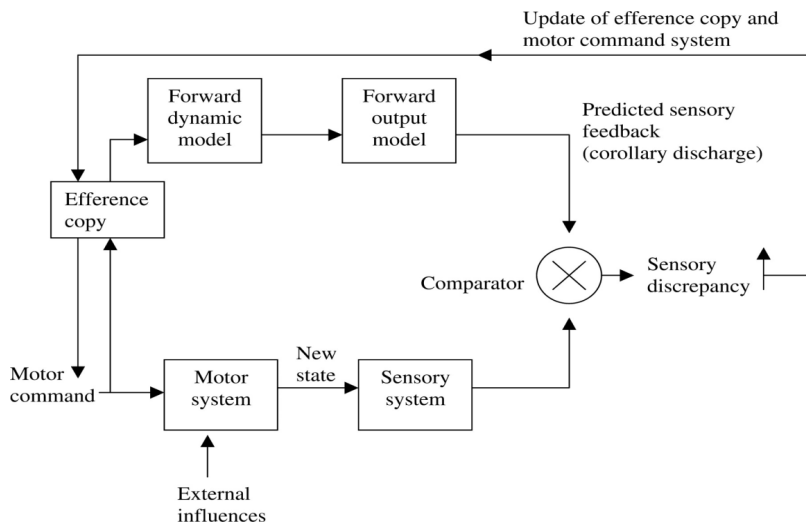

Figure 6.2 A feed forward model of motor commands. A motor (efferent) command produces an efferent copy which contains predictions about the outcome of movement. The predicted sensory outcome is then compared (using visual feedback) with the actual sensory feedback. When the predicted outcome and the actual outcome are matched then there are no sensory disturbances. When predicted and actual outcomes are mismatched then there is an increase sensory disturbance resulting in transient somatic sensations such as pain, discomfort, temperature changes and weight changes.

occluding the participant's right arm. Participants were then asked to move both hands (either side of the mirror board) and to watch the reflection of movement produced by the limb in the mirror. They were then asked to move their hidden arm up and down asynchronously to the hand in view.

McCabe et al. (2005) reported that the effect of moving the hand out of synchrony caused painful sensations (e.g. pins and needles and tingling) in around 15% of the healthy sample. McCabe et al. interpret the origin of this pain to be a mismatch between visual feedback and motor commands. This is because the participant is observing a movement in the mirror that is different to the movement being made by the occluded (actual) hand. The exact mechanism, however, for the generation of pain without injury is unclear. Individuals

The incongruence between the produced movement and the seen movement has been found to cause somatic sensations, including pain in some subjects. McCabe et al. (2005) placed a mirror board

who report pain in response to images may be similar to those who report pain during a mismatch of efferent and afferent signals. Pain responders feel pain in the same location where they observe pain this suggests that pain responders may be feeling a sense of ownership over an external body (injured) body part. If pain responders are more likely to adopt an external body part as their own then we would expect pain responders to report a stronger sense of the rubber hand illusion. In the second part of the experiment we tested whether pain responders were more likely to sensitive to sensory disturbances in general. It is possible that pain responders are very sensitive to internal sensations and that reporting pain during observation of others in pain, is more of a generic phenomenon. Here, we test here if they are more likely to report pain during a mismatch of sensory information. We test both these hypotheses using the rubber hand illusion.

6.2 Method

6.2.1 Participants

52 (mean age 20, SD 1.9) healthy females from the university of Birmingham took part in the study in exchange for course credit. Participants were categorised into three groups based on their response while observing others in pain in Experiment 2.2. This yielded a group of participants who reported pain to at least one painful image (pain responders, $n = 19$). The remaining participants were divided into those who responded to the images with a level of emotion similar to the pain responders ($n=13$) and those who responded with lower emotion ($n = 20$) (see 2.3.3 for results).

6.2.2 Procedure

Participants were studied in pairs. Participant one (P1) sat at a table and placed her right hand into a covered box that blocked the view of her hand. Her left hand was placed in full view in a comfortable position on top of the table.

Participant two (P2) was then asked to place her hand on the table in front of P1 in a position that P1's hidden hand could comfortably occupy. To do this P2 crouched or sat



Figure 6.3 *The experimental setup. P1 sat in chair with right hand occluded by the screen. P2's hand was positioned in place of P1's right hand. P1 was instructed to fixate on P2's hand during all conditions.*

by P1 but remained largely out of view (see figure 6.3). Both participants were asked to wear rubber gloves on both hands and matching black tops so as to keep the appearance of the hands and arms as similar as possible. The same setup was used for each experimental condition.

In the experiment there were four experimental conditions; synchronous stroking (SS), asynchronous stroking (SA), synchronous movement (MS), and asynchronous movement (MA). In condition SS two small paintbrushes were used to synchronously stroke the index fingers of P1's hidden hand and P2's hand on the table. P1 was instructed to concentrate on the stroking of P2's hand. This condition continued for two minutes.

In the asynchronous stroking (SA) condition, synchronous stroking was employed for 60 seconds to evoke the rubber hand illusion. In this particular study we used the

asynchronous stroking as an attempt to attenuate the sense of the illusion. The synchronous stroking is necessary to establish the RHI prior to disturbing the illusion (with asynchronous stroking). Possible consequences of attenuating the illusion are sensory disturbances such as pain, discomfort or peculiarity (McCabe et al., 2005). We investigated this possibility in this study.

The stroking was then switched to asynchronous i.e. tactile stimulation on the hidden hand followed by tactile stimulation on the other person's hand with an interval of no more than 500ms. This asynchronous stimulation lasted for a further two minutes.

In the synchronous movement/tapping (MS) condition, P1 was instructed to move her hidden index finger in synchrony with a metronome. P2 was instructed to move her index finger on the table in the same way. The metronome was set to a speed of 66Hz. To maintain the synchrony of movement, P1 automatically imitated the movement of P2. Participants were instructed to keep moving their index fingers in synchrony until instructed to stop. The movement lasted for two minutes.

In the asynchronous movement/tapping (MA) condition, participants were instructed to begin by moving both of their fingers in synchrony to a metronome as per the procedure for synchronous movement. It was explained before the procedure began that P2 should switch to tapping on the off beat when an instruction to change was given but P1 should continue to tap on the on beat. The instruction to change was delivered after 60 seconds of performing synchronous movements. After P2 changed her finger movement to the offbeat, P1 continued to tap on the on beat and concentrated on the movement of P2's finger. This asynchronous movement condition continued for a further two minutes.

Participants completed each experimental condition once in a counterbalanced order. The entire procedure lasted for one hour.

6.2.3.1 Botvinick and Cohen Questionnaire

Immediately after finishing each condition P1 was asked to fill out the Botvinick and Cohen (1998) questionnaire and the McCabe questionnaire. The Botvinick and Cohen (1998) questionnaire includes eight items describing perceptual qualities, three of which are highly correlated with the rubber hand illusion (Botvinick and Cohen, 1998) (see table 6.1 and appendices six and seven).

Botvinick and Cohen questionnaire: Indicate your response to the following questions by circling the appropriate number ranging from “agree strongly” (+3) to “disagree strongly” (-3)

Stroking: It seemed as if I were feeling the touch of the paintbrush in the location where I saw the other person’s hand touched.

MOVEMENT (Tapping): It seemed as if I were feeling the tap of my finger in the location where I saw the other person’s finger tapping.



Stroking: It seemed as though the touch I felt was caused by the paintbrush touching the other person’s hand.

MOVEMENT (Tapping): It seemed as though my tapping was causing the other person’s finger to tap.



Stroking and MOVEMENT (Tapping): I felt as if the other person’s hand were my hand.

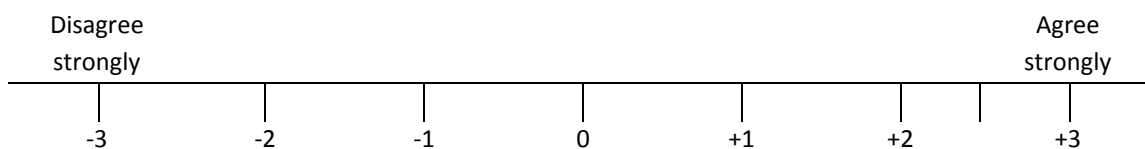

Figure 6.4: Three items of the Botvinick and Cohen (1998) questionnaire used to assess the degree of ownership of another hand. Participants were asked to indicate the extent to which they agreed or disagreed with each statement. The items were adapted for use with the motor or tapping version of the rubber hand experiment.

6.2.3.2 McCabe Questionnaire

The McCabe questionnaire includes nine items used to assess somatic changes during incongruent visuo-motor feedback (McCabe et al., 2003; McCabe et al., 2005; McCabe et al., 2007). The nine items refer to somatic bodily experiences such as painfulness, discomfort and temperature and weight changes. Participants were asked to what extent they agreed or disagreed with each statement from 3 to -3 respectively.

6.3 Results

6.3.1. Experimental Design

A 2 (synchrony, asynchronous/synchronous) x 3 (group, pain responders/non pain responder/emotional responders), mixed ANOVA with was performed using mean ratings for ownership and location of sensation as separate dependent variables. The first analysis (6.3.3) will present data in relation to the dependent variable “location of sensation” (i.e. the degree to which participants agreed to this statement “it seemed as if I were feeling the touch of the paintbrush in the location where I saw the other person’s hand touched”). The second analysis will use the dependent variable of “ownership” (i.e. the degree to which participants agreed to this statement “I felt as if the other person’s hand were my hand”).

6.3.3 Location of Sensation during stroking conditions

Figure 6.5a shows that pain responders recorded similar ratings for feeling the sensation of touch on the rubber hand during synchronous and asynchronous conditions. There was a significant main effect of condition ($F(2, 49), 25.5, p < 0.001$). The illusion of touch sensation located at the other persons hand was diminished in both control groups in asynchronous stroking relative to synchronous stroking. Pain responders perceived very similar levels of touch from the rubber hand in synchronous and asynchronous stroking.

There was a significant interaction effect between group and synchrony ($F(2, 49) = 3.2, p=0.05$). Post hoc paired t-tests reveal that there was a significantly lower mean rating for non responders during asynchronous stroking relative to synchronous stroking ($t(20) = 3.8, p < 0.001$). There were also significantly lower ratings during asynchronous stroking relative to synchronous stroking in emotional responders ($t(14) = 3.2, p=0.01$). There were no significant differences between mean ratings for pain responders during synchronous or asynchronous stroking ($t(19) = 1.1, p = .30$) (see fig 6.5a).

6.3.4. Ownership during stroking conditions

Figure 6.5b illustrates that the sense of ownership was not diminished during asynchronous stroking for pain responders. There was no significant main effect for synchrony ($F(1, 37) = 1.5, p = 0.7$). The absence of ownership or very low scores of ownership during the synchronous stroking for the emotional responders condition makes any interpretation of ownership during asynchronous stroking very problematic. There was also no significant interaction effect between group and synchrony ($F(2, 49) = 0.9, p = 0.41$)

A

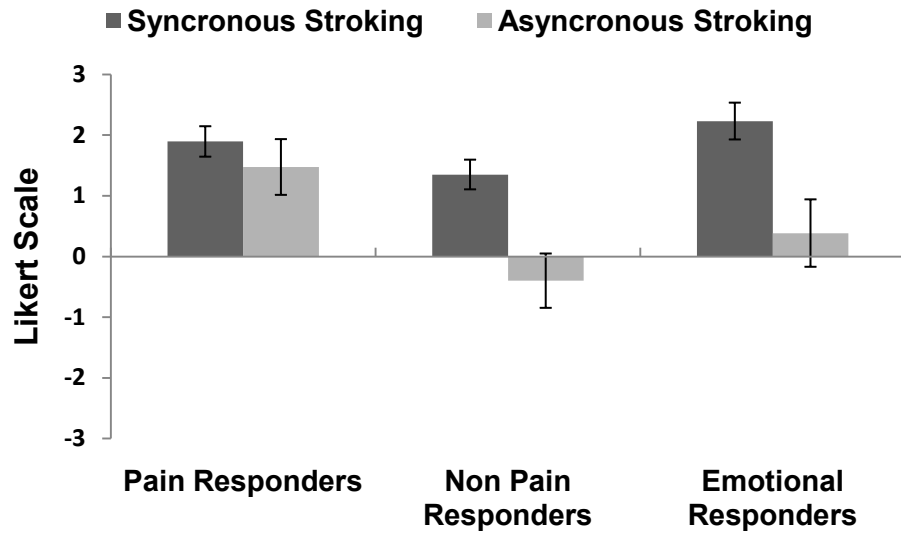

B

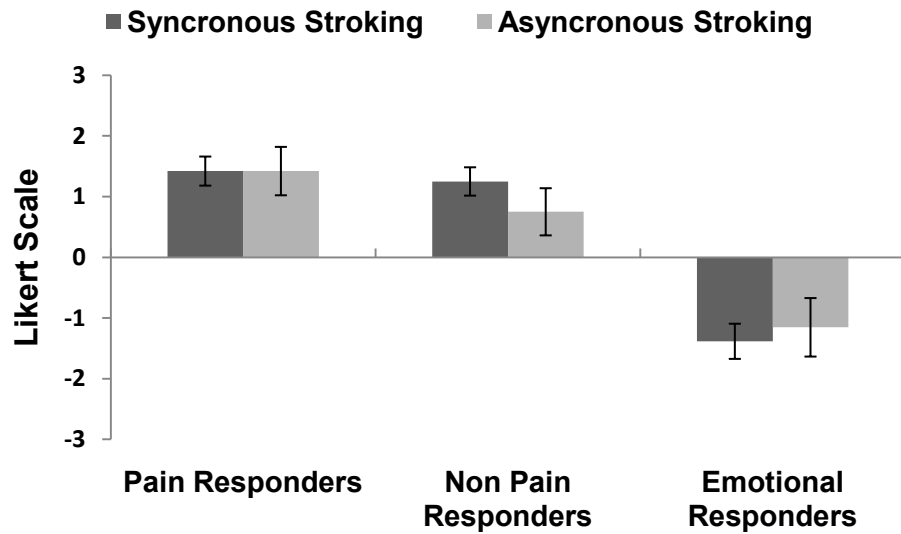

Figure 6.5: A) The group mean ratings for the extent to which participants feel touch sensations at the location of the other participant's hand during synchronous and asynchronous stroking. B) The group mean ratings for feelings of ownership over the other participant's hand during synchronous and asynchronous stroking. Error bars represent standard errors.

6.3.5 Location during tapping

Figure 6.7a illustrates that mean ratings for location (i.e. it felt like the tapping was coming from the hand that was being observed) were similar during synchronous and asynchronous tapping for each group and that the main effect of synchrony was not significant ($F(1, 49), 0.01, p = 0.96$). The interaction between group and synchrony was also not significant ($F(2, 49), .24, p = 0.78$).

6.3.6 Ownership during tapping

Figure 6.7b illustrates that pain responders report more ownership over the rubber hand during asynchronous tapping than synchronous tapping. Both control groups report very similar levels of ownership in during synchronous and asynchronous tapping. There was no main effect of synchrony ($F(1, 49), 0.90, p = 0.34$) and no main interaction effect between group and synchrony ($F(1, 49), 0.21, p = 0.80$).

A

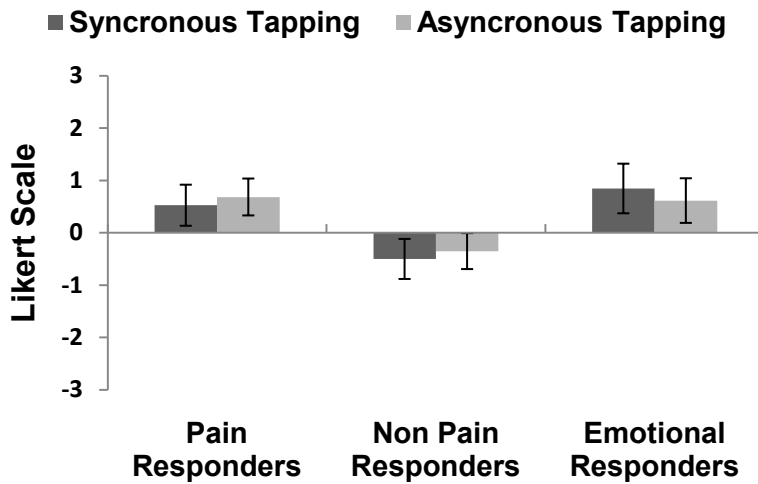

B

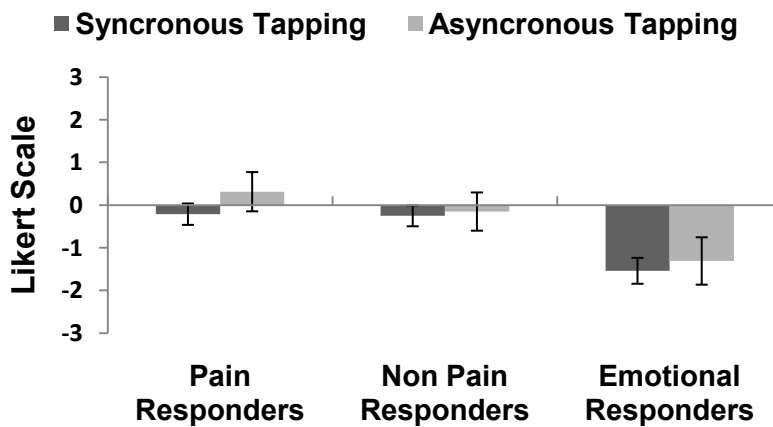

Figure 6.7: A) The group mean ratings for the extent to which participants feel touch sensations at the location of the other participant's hand during synchronous and asynchronous tapping. B) The group mean ratings for feelings of ownership over the other participant's hand during synchronous and asynchronous tapping. Error bars represent standard errors.

6.3.7 Somatic changes during stroking conditions

Pearson's χ^2 test of independence was performed to investigate the relationship between frequency somatic changes for group with each condition (synchronous stroking, asynchronous stroking, synchronous movement, asynchronous movement) as a separate variable.

Table 6.1 illustrates the frequency of participants who reported a somatic change (e.g. weight changes, sensations of heat or coldness, feeling an extra hand or losing a hand) as a function of group during each condition (synchronous stroking, asynchronous stroking, synchronous movement, asynchronous movement). The frequency of participants per group to report somatic changes was not significantly different during synchronous stroking ($\chi^2(2, N=53) = 2.2, p = 0.34$), synchronous tapping ($\chi^2(2, N=53) = 2.2, p = 0.32$) and asynchronous tapping ($\chi^2(2, N=53) = 1.1, p = 0.56$). The percentage of participants who reported somatic symptoms was higher in non pain responders compared with emotional responders and pain responders during asynchronous stroking. There was a significant relationship between somatic reports and group ($\chi^2(2, N=53) = 6.2, p = 0.03$) (see table 6.1).

6.3.8 Somatic changes during synchronous and asynchronous stroking

The McNemar repeated measures statistic was performed to investigate the relationship between frequency somatic changes for group with each condition (synchronous stroking, asynchronous stroking, synchronous movement, asynchronous movement) as a separate variable.

The frequency of pain responders to report somatic symptoms did not differ during synchronous/asynchronous stroking ($\chi^2(2, N=19) = 0.0, p = 1.0$). The percentage of emotional responders and non pain responders who reported somatic sensations increased during asynchronous stroking compared with synchronous stroking. The relationship between synchrony was significant for emotional responders ($\chi^2(2, N=14) = 4.6, p = 0.03$) and for non responders ($\chi^2(2, N=21) = 5.1, p = 0.02$).

6.3.9 Somatic changes during synchronous and asynchronous tapping

The McNemar matched pairs statistic was carried out on frequency of participants per group who reported somatic symptoms during synchronous or asynchronous tapping. The percentage of pain responders who reported somatic changes did not differ during synchronous and asynchronous tapping ($\chi^2(2, N=19) = 0.91, p = 0.31$). There was also no relationship between frequency of participants who reported somatic symptoms during synchronous and asynchronous tapping conditions in the emotional responders group ($\chi^2(2, N=14) = 0.20, p = 0.66$) or non responders group ($\chi^2(2, N=21) = 1.5, p = 0.21$) (see table 6.1 for percentage of participants who reported somatic changes and break down of prevalence of somatic symptoms).

Pain Responders				
	SS	SA	MS	MA
<i>Frequency of reports (% participants who reported symptoms)</i>	12 (63)	12 (63)	10 (52)	13 (68)
Pain	1 (5)	0 (0)	0 (0)	0 (0)
Discomfort	5 (26)	5 (26)	2 (10)	4 (21)
Lost Hand	4 (21)	3 (15)	5 (26)	2 (10)
Hotter	5 (26)	2 (10)	1 (5)	2 (10)
Colder	3 (15)	0 (0)	1 (5)	1 (5)
Heavier	6 (31)	8 (42)	6 (31)	8 (42)
Lighter	4 (21)	2 (10)	3 (15)	0 (0)
Extra	7 (36)	6 (31)	6 (31)	8 (42)
Peculiar	12 (63)	14 (73)	12 (63)	14 (73)
Emotional Responders				
	SS	SA	MS	MA
<i>Frequency of reports (% participants who reported symptoms)</i>	10 (71)	14(100)	10 (71)	11 (79)
Pain	1 (7)	1 (7)	1(7)	0 (0)
Discomfort	1 (7)	4 (29)	1 (7)	2 (14)
Lost Hand	5 (36)	1 (7)	2 (14)	1 (7)
Hotter	3 (21)	1 (7)	4 (29)	3 (21)
Colder	0 (0)	1 (7)	0 (0)	0 (0)
Heavier	3 (21)	4 (29)	4 (29)	6 (43)
Lighter	3 (21)	2 (14)	3 (21)	1 (7)
Extra	5 (36)	7 (50)	6 (43)	4 (29)
Peculiar	13 (92)	14(100)	12(86)	12(86)
Non Pain Responders				
	SS	SA	MS	MA
<i>Frequency of reports (% participants who reported symptoms)</i>	10 (48)	17 (80)	9 (43)	13 (61)
Pain	0 (0)	0 (0)	0 (0)	0 (0)
Discomfort	1 (4.7)	5 (24)	1 (4.7)	2 (9.5)
Lost Hand	0(0)	4 (19)	2 (9.5)	4 (19)
Hotter	3 (14)	2 (9.5)	2 (9.5)	1 (4.7)
Colder	0(0)	1 (4.7)	0 (0)	0 (0)
Heavier	6 (29)	3 (14)	2 (9.5)	5 (24)
Lighter	1 (4)	4 (19)	0 (0)	1 (4.7)
Extra	7 (33)	9 (47)	3 (14)	9 (47)
Peculiar	18 (86)	17 (81)	9 (42)	10 (47)

Table 6.1: Frequency of each somatic sensations in all 4 conditions presented by group (SS: synchronous stroking, SA: asynchronous stroking, MS: synchronous movement/tapping, MA: asynchronous movement/tapping).

6.4 Discussion

Here we present two unique findings. Firstly, the illusion of ownership over another person's hand is not attenuated during asynchronous stroking conditions in pain responders. Our second finding demonstrates for the first time that asynchronous stroking generates somatic disturbances because of visuo-tactile conflict.

6.4.1 Asynchronous stroking does not diminish rubber hand illusion

Pain responders reported similar experiences of the illusion in the asynchronous stroking as the synchronous stroking condition. This finding is not in line with previous research demonstrating that the rubber hand illusion is significantly attenuated during asynchronous stroking (Aspell, Lenggenhager and Blanke, 2009; Botvinick and Cohen, 1998; Ehrsson, Passington and Holmes, 2005; Moseley, Olthof, Venema, Don, Wijers, et al., 2008; Makin, Holmes and Ehrsson, 2008; Tsakaris et al., 2006; Tsakaris and Haggard, 2005); Tsakaris et al. (2006) used the distance between the perceived hand position before and after the induction procedure ('proprioceptive drift'), in contrast to the Botvinick and Cohen questionnaire scores. Items from the Botvinick and Cohen questionnaire have also demonstrated an attenuated sense of the illusion during asynchronous stroking, indicating that both objective and subjective measures equally reflect the strength of the illusion (Aspell, et al., 2009). Synchronous stroking is considered as a necessary requirement for ownership over an external body part (Tsakiris, 2010; Makin, Holmes and Ehrsson, 2008). Here, reports of body ownership during asynchronous stroking suggest that strong correlations between tactile and visual input are less important for ownership over another person's hand, in a minority of healthy participants. It is possible that visual, not tactile,

information drives feelings of ownership in the rubber hand illusion in a minority of participants. Visual information about pain in others generates reports of pain in the observer. Here, we provide some preliminary evidence suggesting that ownership over another person's hand is sometimes not dependent on strong visuo-tactile correlations (Tsakiris, 2010), also suggesting that visual information may, in some cases, be a more dominant factor in body ownership during this modified rubber hand illusion. In a recent imaging study Tsakiris, Longo and Haggard, (2010) have demonstrated that the insula plays a role in body ownership. In addition, in Chapter three we demonstrated that the insula is associated with pain generated by observation of others in pain. The insula may play role in both the generation of pain by observation of pain on an external body part.

An alternative explanation for the effects observed during the asynchronous condition may be the strength of the illusion during the initial synchronous induction period. In each trial synchronous stroking was used to generate a sense of body ownership prior to the introduction of the asynchronous stroking. It is possible that pain responders felt a very strong sense of the illusion, which was prolonged during asynchronous stroking. It is possible that reports of sensation of touch and ownership are more representative of the strength or carry over effects of synchronous stroking condition, as opposed to specific effects of the asynchronous stroking. It is however, unlikely that the strength of the illusion during synchronous stroking alone could account for the strength of the illusion during asynchronous stroking. The total scores for the two main aspects revealed no difference between pain responders and controls on the reported perceptual effects for the synchronous stroking condition. This is in line with the results of previous studies demonstrating the robustness of the illusion thought to occur in around 80% of samples (Armell and Ramachandran, 2003; Botvinick and Cohen, 1998, Tsakaris and Haggard,

2005). Despite the strength of the illusion in both control groups, the mean rating for sensation of touch and ownership was significantly reduced during asynchronous stroking.

During synchronous stroking, pain responders and non responders both reported a feeling of ownership and a sense of sensation at the location of the other person's hand, suggesting that these two groups of participants experienced a coherent sense of ownership over the other person's hand. Emotional controls reported significantly less sense of ownership than pain responders and non pain responders during synchronous stroking. Despite not reporting a sense of ownership over the other person's hand, emotional responders reported feeling the sensation of touch from the other person's hand. It is unclear how a proportion of participants feel a sensation of touch and ownership of the limb are dissociated in this way.

Mislocalisation of touch from actual body locations to other locations in peripersonal space using distracter lights has been reported (Pavani, Spence and Driver, 2001). Participants' real hands were hidden out of view while holding foam cubes in their hand. Placed in front of them was a fake hand which also appeared to be holding foam cubes; attached to the foam cubes were distracter lights. Participants' thumb or index fingers were stimulated with tactile vibrators and participants were required to state the location of the tactile sensation. Distracter lights were activated simultaneously with the tactile vibration, sometimes at the location of the participant's hand and sometimes at the location of the rubber hand. When distracter lights were observed at the location of the rubber hand, touch was mislocated to the rubber hand.

A similar type of sensory mislocalisation has been observed with auditory stimuli in the ventriloquism effect (Bertelson, Vroomen, De Gelder, and Driver, 2000). The ventriloquism effect occurs when sound is mislocated because of bias visual cues away

from the source of the sound. It may be likened to the mislocalisation of touch away from the true source of the touch in this rubber hand illusion, and can be present despite the absence of ownership. The visual cue of the brush may become more dominant than the touch of the hand. Armel and Ramachandran (2003) report that it is possible to use the rubber hand illusion to evoke a sense of ownership over a table; alternatively, this could be explained in terms of the mislocalisation of touch rather than ownership over the table per se. Austin, Soto-Faraco, Enns and Kingstone (2004) performed a similar study to examine whether the fake body part was incorporated as part of the body schema. They demonstrated that the mislocalisation of touch disappeared when the fake hand was placed in a position incompatible with the participant's real hand. Austin et al. (2004) concluded that the rubber hand had been incorporated into the participants' body schema and as a result participants felt a sense of ownership. The congruent hand posture may be necessary for both ownership and mislocalisation of touch, but here we demonstrate that, at least in some subjects, body ownership and mislocalisation of touch are dissociable.

Pain responders report a sense of body ownership and feeling of touch sensation to a greater extent than controls during synchronous and asynchronous stroking. Overall the results indicate that pain responders are more readily able to adopt another person's body part as their own regardless of whether the incoming information is synchronous or not. This suggests that the tactile/proprioceptive afferent information is less important for integration of foreign body parts in pain responders, than for those individuals who do not feel pain when they look at another person in pain. A more flexible sense of body part ownership could in part form the basis of how pain is mislocated from one body part location to another. It would be interesting to modulate the amount of incoming sensory information required to experience ownership over another limb within this population.

6.4.2 Pain and sensori-motor conflict

We predicted that incongruence of visual feedback and motor commands would produce a sensation of pain, as demonstrated by McCabe et al. (2005). Participants did not report any pain during the asynchronous tapping condition; this was the only condition with no accompanying pain reports. Unfortunately, we only demonstrated a very weak sense of ownership during the synchronous tapping and therefore it was difficult to disrupt sensory-motor congruence. Participants were required to tap in sync with each other following the beat of a metronome. While most participants found synchronous tapping initially quite straightforward, it was difficult to maintain complete synchrony during the two minute trial. McCabe et al. (2005) used mirrors to provide feedback to the participants. In comparison, we required that both participants maintained accurate timing when tapping their fingers to a metronome. It is possible that the tapping movements produced by two participants may not have been provided completely synchronous feedback in the same way that a mirror can. Without perfect synchrony of tapping, match between incoming sensory information and motor commands may not have been achieved. In the absence of a match, the change or contrast to a mismatch is attenuated and no somatic changes were experienced. Pain responders did score highest on items that represent body ownership and feeling of sensation which would suggest a degree of match and/or mismatch between visual information and motor commands. Despite these scores, the change between synchronous and asynchronous movement conditions failed to yield reports of pain. We are already using more sophisticated methods including projecting a tapping hand using video equipment to induce a stronger sense of the illusion during tapping or motor versions of the rubber hand.

6.4.3 Somatic reports during sensori-motor conflict

In general, the number of somatic reports increased during asynchronous tapping, suggesting that although pain did not occur that there was some sensory disturbance induced by the during sensori-motor conflict. This is in line with evidence from McCabe et al. (2005) suggesting that when visual information does not match the intended motor command and resulting action, sensory disturbances are generated.

6.4.4 Somatic symptoms during stroking conditions

Here we demonstrate that incongruent visuo-tactile information (asynchronous stroking) results in both a reduced sense of ownership and increase in somatic symptoms, including discomfort, temperature and weight changes in both control groups. Other studies have shown that visuo-tactile stimulation of a rubber hand, in a synchronous fashion, can result in somatic sensations. Synchronous stroking produced equal levels of pain experience as the asynchronous stroking condition however there was a five times increase in reports of discomfort during asynchronous stroking in non responders and a four times increase in emotional responders. Moseley et al. (2008) also demonstrated that homeostatic functions such as temperature regulation are modulated during the rubber hand illusion (Moseley et al. 2008). With ownership over a rubber hand, the temperature of the participant's real hand was significantly reduced (Moseley et al., 2008). The greater the strength of the rubber hand illusion, the colder the temperature of the hand. Consistent with other rubber hand studies, the hand was significantly cooler during synchronous stroking. Other tactile illusions have also demonstrated somatic feelings such as the numbness illusion (Dieguez, Mercer, Newby and Blanke, 2009). The numbness illusion occurs when two people place their palms together and both index fingers are stroked. Usually, during synchronous stroking relative to asynchronous stroking of the index fingers, a sense of numbness occurs. The numbness illusion does not rely on visual

information like the rubber hand illusion. Here we demonstrate that disruption of touch, vision and proprioceptive integration induced by asynchronous stroking produces an increase in somatic symptoms relative to synchronous stroking. When subjective feelings of ownership are unchanged, the frequency of somatic symptoms remains unchanged, as demonstrated by pain responders.

McCabe et al. (2005) explained that sensory disturbances (i.e. pain, temperature changes etc) during sensori-motor conflict occur because of a mismatch between observed and performed action. For example, a motor (efferent) command produces an efferent copy which contains predictions about the outcome of movement. The predicted sensory outcome is then compared (using visual feedback) with the actual sensory feedback. When the predicted outcome and the actual outcome are matched then there are no sensory disturbances. When predicted and actual outcomes are mismatched then there is an increase sensory disturbance resulting in transient somatic sensations such as pain, discomfort, temperature changes and weight changes. It is possible that a similar type of conflict could occur between incongruent visuo-tactile information resulting in somatic disturbances.

CHAPTER SEVEN: GENERAL DISCUSSION

7.1 Overview

This chapter provides an overview of the findings demonstrated in this thesis. The general aim of the thesis was to investigate acute pain without injury using observation of pain as a model for generating pain. Previous research has focused upon empathy for the pain of another and has demonstrated that emotional (Singer et al., 2004; Jackson et al., 2005) and sensory (Avenanti et al., 2005; Avenanti et al., 2006; Bufalari et al., 2007) components of pain are generated when observing another in pain. Sensations of pain have also been generated by observing others in pain (Fitzgibbon et al., 2010). Fitzgibbon et al. reported that a small minority of phantom limb patients reported pain or increased pain in their phantom when observing or hearing about pain in others. The concept that pain is generated primarily by visual input is a novel and unusual concept that remains largely unexplored. To date, no studies have investigated the experiential qualities resulting from observation of others in pain in healthy individuals or, more specifically, if they can feel pain when observing another in pain. Here we will re-state the aims of the thesis and give an overview of some of the main findings.

7.2 Aims of the thesis

This thesis aimed to first investigate pain generated by observation of others in pain. In general, it was anticipated that pain generated by observation of pain in others is the same as pain generated by a noxious stimuli. In order to test this hypothesis we employed fMRI

to investigate whether pain sensation generated by others in pain was associated with brain activity occurring with pain generated by, for example, noxious heat. It was anticipated that pain generated by visual observation of pain could be related to the way pain in others is perceived, general over reporting of symptoms, memories of pain and other perceptual aberrations; all of these factors have been investigated. Sensation of pain that is generated via observation of somebody else raises the question about the extent to which we share the experiences of others. The distinction between self and other often underpins the ability to take different perspectives. We therefore investigated the ability of pain responders to take different visual perspectives compared to spatial perspectives to investigate whether pain responders would more readily be able to adopt the perspective of others. A way of investigating the self/ other distinction is to manipulate a sense of body ownership. Usually we only attribute sensations to parts of the body over which we feel ownership. To further investigate how sensations can be referred we used an adapted version of the rubber hand illusion. We anticipated that pain responders would be more readily able to adopt another person's hand into their body schema and report an increased sense of tactile sensation at the location of the other person's hand. Pain responders may also be more likely to report sensory disturbances (i.e. pain, discomfort) generated by sensori-motor conflict; we investigated this possibility using a motor version of the rubber hand illusion.

7.3 Neural correlates of pain generated by observation of pain in others

Here we demonstrate for the first that a significant minority of healthy individuals report a sensation of pain triggered by the observation of others in pain. This is the first study to demonstrate that physical sensations of pain are generated by observing another in pain in a sample of healthy controls, which adds to the existing body of literature reporting

other vicarious sensations, such as touch (Bannisey and Ward, 2007; Blakemore et al., 2005). Pain responders did not perceive the painful images to be more painful than both non pain responder groups, suggesting that pain responders perceive or process painful visual stimuli in a similar way to the two control groups.

Pain sensation generated by others in pain is associated with activity in the pain matrix, more specifically, the primary and secondary somatosensory cortices, associated with the coding of location and intensity of pain sensation (Price, 2000) (see Chapter Three). This demonstrates that the pain reported by a significant minority of participants is underpinned by the same coding mechanisms involved in physical pain. Pain generated by observation of others in pain implies a sense of shared experience. Shared somatic experiences are often explained in terms of shared representations and underpinned by mirror neurons (Blakemore et al., 2005; Gallese, 2005; Keysars et al., 2004). It is possible that representations of pain are activated in the observer in response to another in pain. Most of the time the representations are limited to the affective component of pain; however, in pain responders a complete representation of pain may be activated automatically (i.e. physical sensations of pain). It is plausible that when we see another in pain, the representational content of the pain is based on first person experiences, in the same way that representations of emotions generated by others in an emotional state are based on first person experiences of emotion (Gallese, 2005; Freedberd and Gallese, 2007; Keysars and Gazzola, 2009; Niedenthal, 2007). Here, it is assumed that pain generated in the absence of injury is an automatic and implicit process (Gallese, 2001).

The fMRI findings are also consistent with evidence from single cell recordings in monkeys demonstrating that cells in the ventral intraparietal cortex (VIP) which have strong anatomical connections to the somatosensory cortices (SII and BA2), fire when

observing touch and also feeling touch (Ishida, Nakajima, Inase and Murata, 2009). The extent to which individual neurons fire when observing and experiencing a pain state in humans is however unclear. The average isotropic voxel sizes used in fMRI (e.g. 3mm) are large enough to include a subset of neurons that code representation of pain generated by others and a separate set of neurons that code noxious input in the individual. Additionally, the smoothing of the data in the preprocessing stage, can blur the signal generated from a spatially contiguous pool of voxels (Gazzola and Keysars, 2009). It is therefore possible that neurons involved in observed pain and felt pain are distinct, yet spatially intertwined (Morrison and Downing, 2007). Jackson, Rainville and Decety (2006) demonstrated a partial overlap of observed and felt pain also consistent with Morrison and Downing (2007). Recently, Gazzola and Keysars (2009), used single subject unsmoothed data to investigate if the same voxels responded to observed and performed action. They demonstrated that all 16 subjects showed activation of observed and experienced action in the same voxel in the ventral premotor and inferior parietal cortex, the same location in which mirror neurons have been found in monkeys (Fogassi, Ferrari, Gesierich, Rozzi, Chersi et al., 2005). When the unsmoothed data was compared to smoothed group level data, the areas of overlap were similar. Evidence for shared voxels in pain is provided by single cell recordings in the cingulate cortex region that were active during observation of pain and experience of pain in a small number of patients with affective disorders (Hutchinson, Davies, Lozano, Tasker and Dostrovsky, 1999).

The theory of embodied simulation posits that first person states are accessed automatically at a subconscious level in order to understand third person states (Gallese, 2005). Evidence to suggest that first person representations of pain are required to understand third person experiences is provided by an emerging literature on autism and

mirror neurons. Individuals with autism are substantially impaired in understanding self referential and other referential states (Lombardo, Chakrabati, Bullmore, Sadek, Pasco et al., 2010). Brain activity underpinning understanding of emotions (pars occipitalis, insula and the amygdala) increased when observing emotional expressions (e.g. fear, happiness, sadness, etc.) in age and IQ matched controls relative to children with autism. The reduced activation in the areas associated with observation of emotional expressions in children with autism suggests that the basic coding mechanism allowing the understanding of others is impaired (Lombardo et al., 2010). Presumably individuals with autism lack the functional neural architecture (i.e. mirror neurons) to imitate emotions of others (Dapretto, Davies, Pfeifer, Scott, Sigman et al., 2006) as well as the actions of others (Théoret, Halligan, Kobayashi, Fregni, Tager-Flusberg, 2005). The inability to represent others' actions and emotions seems to emerge from an inability to personally experience states including pain (Gallese, 2001). Pain generated by observation of others in pain implies a sense of shared experience. Shared somatic experiences are often explained in terms of shared representations. The extent to which one is able to take the perspective of others may depend on the extent that self/other representations of pain are shared. For example, Avenanti et al. (2009) investigated the specific effects of state and trait empathy upon modulation of motor evoked potentials. They found that perceived pain intensity was inversely correlated with changes in motor evoked potentials. That is to say, participants who rated the stimuli as more intense demonstrated more motor inhibition. Equally, participants who were more able to take the perspective of another also had increased motor inhibition. It is plausible that representations of others pain are modulated according to how pain is personally experienced by the individual. It is likely that pain responders are generally quicker to bridge the gap between self and other in most situations, given their increased ability on visual perspective taking tasks (Chapter Five). During visual

perspective taking participants were asked to represent both self perspective and other perspective. Pain responders demonstrated little differences when asked to adopt self/other perspectives relative to non responders. It is possible that pain responders have a more flexible sense of body ownership, requiring only minimal visual-tactile integration in order to experience another person's body part as their own. This suggests that pain responders represent self and others as more similar than most individuals. Similarity between self and other has been reported by a sample of patients with Fibromyalgia (Frith, 1999; Karst et al. 2005). It has been demonstrated that Fibromyalgia patients lacked an ability to judge whether touch was self generated or performed by someone else. Further research could investigate whether confusion between self and externally generated sensations is found in those who report pain after viewing others in pain.

Pain reports were associated with a similar pain memory which is consistent with others studies suggesting that how we process another in pain depends on previous experience with pain. Cheng, Lin, Lui, Hsu, Lim et al. (2007) demonstrated that medical practitioners with at least two years of experience of acupuncture showed less activation in the ACC, insula, PAG and SII, when observing images depicting needles inserted into hands than control participants. These results suggest that familiarity of an observed painful stimulus may lead to habituation of a response to observed pain in the same way that the response to noxious stimuli habituates after repeat exposure. The extent to which one is able to take the perspective of others may depend on the extent that self/other representations of pain are shared. For example, Avenanti et al. (2009) investigated the specific effects of state and trait empathy upon modulation of motor evoked potentials. They found that perceived pain intensity was inversely correlated with changes in motor

evoked potentials. That is to say, participants who rated the stimuli as more intense demonstrated more motor inhibition. Equally, participants who were more able to take the perspective of another also had increased motor inhibition. It is plausible that representations of others pain are modulated according to how pain is personally experienced by the individual. Given the high number of pain responders who reported pain and also reported a pain memory, personal pain representations are likely to influence experiential qualities associated with pain in others. As such, a more direct access to pain content produces more overlap between self and other representations of pain. For example, individuals who feel pain when eating cold foods like an ice lolly, presumably because of sensitive teeth, would be more likely than others who have not had this experience to share representations of pain related to eating cold foods. We are currently investigating this possibility.

7.4 Visual representations of pain

It is unlikely that visual information is unique in the generation of pain in the absence of noxious stimuli. For example, semantic information is sufficient to evoke a representation of pain in the reader. Kelly et al. (2007) showed participants painful words such as ache and stinging in contrast with non pain words such as stool and decorate whilst undergoing fMRI. They found that areas of the brain involved in the affective components of pain were activated when participants read pain related words compared with non pain related words. Motor and pre-motor cortices were activated during the reading of words related to movement of body parts such as hands and feet (Hauk, Johnsrude and Pulvermuller, 2004). Recall of sounds activates areas of the brain underpinning processing of sound (Wheeler, Petersen and Buckner, 2000). Visual information is a useful way of

triggering memories, thoughts and feelings; however it is also plausible that pain can be generated by imagination or by being told of another in pain as reported by Fitzgibbon et al. (2010). Here we demonstrate that the S1 and S2 are activated during sight of others in pain. It is well known parts of the S1 and S2 receive input from areas that code visual and auditory such as the ventral intraparietal area (VIP) and inferior parietal lobule (IPL) (Keysers, 2010). The presence of bi-modal neurons coding touch and observation of touch in monkeys indicates it is possible to generate the same phenomenal experience from both first and third hand visual experience (Ishida et al, 2009). Therefore, it is plausible that the visual representation of pain is sufficient for an experience of pain, however, at present it is unknown to the extent that a pure visual painful input drives the experience of pain during vicarious pain experience.

7.5 Pain in perspective

Pain processing is no longer a system considered as a hardwired, unitary system that occurs as a result of tissue damage (Wall, 1999). Pain is considered as separate from a more general unpleasant feeling, because of its somatic component. Despite the subjective, sometimes capricious, nature of pain, it is still peculiar to conceptualise the idea of experiencing pain after observation of another in pain. We are however, much more familiar with idea of experiencing emotions via observation of emotion (Dapretto et al., 2005); presumably we learn and develop these emotions through interaction with others. It is intuitive to experience sadness when watching another person cry; it is not intuitive to experience pain when we watch another person in pain. This thesis suggests that we automatically and implicitly model the ‘states’ of others, even states with somatic components, such as pain (Keysars and Gazzola, 2009). It is plausible that interaction with

others shapes the meaning and expression of pain behaviour (Derbyshire, 2006).

Observations of others' emotional states, for instance, potentially develop because of constant embodiment of others' emotional states. It is possible that we experience different representations of pain through embodying different pain experiences in others. There is variance in pain experience because what pain comes to mean, and how it is ultimately experienced, is predominately a function of interaction with others. The mechanism underlying pain generated by observation of others in pain and pain resulting from injury is likely to differ, however they both likely lead to activation of pain representations. Given the resulting pain representations from both acute pain and vicarious pain, I would speculate that the pain experience associated with observation of others in pain, is the same as pain generated by acute pain (i.e. there is no functional difference between pain caused by acute pain and pain generated by observation of others in pain).

Without strong significance and aversion from pain it is unlikely that pain would still feel unpleasant. For example, even when the ability to locate the intensity, location and quality of sensation is intact, pain may bear no motivational significance unless it is strongly connected to affective/evaluative properties. Patients who have undergone cingulotomy, (a procedure which a lesion is made to areas of the brain, particularly the anterior cingulate cortex, to reduce intractable pain sensations) (Yen, Kung, Su, Lin, Howng et al., 2005) report an indifference towards their pain: for instance they have said, "In fact it's still agonising, but I don't mind" (Brand and Yancy, 1997, p. 210). Without significance or aversion from, say, an intense stinging or stabbing pain, there is no significance to the pain experience (Brand and Yancy, 1997; Grahek, 2001). In healthy participants, affective components exacerbate pain intensity (Ploghaus, Narain, Beckmann, Clare, Bantick et al., 2001) and in chronic pain patients, anxiety can maintain or prolong the problem (McKracken, Zayfert and Gross, 1992). It is possible that embodied stimulation of others

pain could also form the basis of chronic pain (Gallese, 2001). This thesis has demonstrated that pain is generated by observation of others in pain. As such, this type of pain is very fleeting, lasting for no more than a couple of seconds. It is very hard to compare this type of pain to the intractable pain experienced in functional pain. However, it is possible that pain representations that are activated via a mechanism such as others in pain but instead of a fleeting pain experience, the pain representations could be permanently maintained by others mechanisms (e.g. maladaptive cognition, anxiety and/or depression). Weakening or strengthening the emotional experience associated with pain through a process of embodied simulation could weaken or strengthen the intensity of pain.

The lack of ability to experience aversion from the other unpleasant experiences is experienced when brain areas linked to functional processing of, for instance, disgust are damaged. For example, lesions to the insula, the area underpinning disgust representations, impairs the ability to recognise disgust in others as well as firsthand experiences of disgust (Adolphs, Damasio, Tranel, Calder, Keane, Manes, Antoun and Yound, 2000). Individuals who are not able to represent the states of others possess limited ability to experience those states themselves (Dapretto et al., 2006; Iacoboni and Dapretto, 2006; Oberman and Ramachandran, 2007). Adults diagnosed with autistic spectrum disorder also fail to represent pain in the same way as typical adults, demonstrated by a lack of reduction in cortico-spinal excitability when observing others in pain (Minio-Paluello, Baron Cohen, Avenanti, Walsh and Aglioti (2009). Usually in typically developed adults, cortico-spinal excitability reduces when observing others in pain (Avenanti et al., 2005; 2006), which is usually taken as a proxy of empathy for others in pain. The absence of direct resonance between self and other pain may change the way that pain is personally experienced. The

inability to represent pain in others may underpin reduced sensitivity or indifference to pain, commonly reported by individuals with autism (Militeri, Bravaccio, Falco, Puglisi-Allegra, Pascucci, et al., 2000).

7.7 Domain specific pain observation

We have discussed how self/other representations of pain are potentially shared by pain responders, especially when they have experienced a similar type of pain to pain that is observed. It is likely that pain responders are generally quicker to bridge the gap between self and other in most situations, given their increased ability on visual perspective taking tasks (Chapter Five). During visual perspective taking participants have to represent both self perspective and other perspective. Pain responders demonstrated little differences when asked to adopt self/other perspectives relative to non responders. The illusion of ownership over another person's hand is not attenuated during asynchronous stroking conditions in pain responders. Non responders demonstrate an attenuation of ownership during asynchronous stroking in line with numerous studies demonstrating that weak visuo-tactile integration diminishes the extent to which ownership is felt over another person's hand (Aspell, Lenggenhager and Blanke, 2009; Botvinick and Cohen, 1998; Ehrsson, Passington and Holmes, 2005; Moseley, Olthof, Venema, Don, Wijers, et al., 2008; Makin, Holmes and Ehrsson, 2008; Tsakiris et al., 2006; Haggard and Tsakiris, 2005). It is possible that pain responders have a more flexible sense of body ownership, requiring only minimal visuo-tactile integration in order to experience another person's body part as their own. This suggests that pain responders represent self and others as more similar than most individuals. Similarity between self and other has been reported by a sample of patients who report auditory hallucinations and a group of Fibromyalgia patients

(Frith, 1999; Karst et al. 2005). For example, both patient populations lacked an ability to judge whether touch was self generated or performed by someone else. In Chapter Two, pain responders also reported higher than average numbers of anomalous experiences such as hallucinations. Nine out of ten responders reported they felt the presence of someone else despite the fact that there was no one present or detected a smell that no one else detected. It is possible that the high number of perceptual anomalies reported by the pain responders may stem also from the way that self and other are represented in pain responders. Given that the increased ability to adopt somebody else's perspective and also the relatively high number of perceptual experiences, both unrelated to pain, the mechanism underpinning pain generated by others in pain is unlikely to be pain specific. It is more likely that it is a general mechanism which represents the other as very similar to, if not the same as, the self. It is plausible that there is a temporary, automatic, confusion between self and other when pain responders view another in pain.

We have investigated the phenomenon of pain sensation generated by observing another in pain in an embodied simulation framework. Embodied simulation assumes representations generated by observation of others are generated at a neural level, but not necessarily at a phenomenological level. However, it is likely that, if there is a direct overlap between self and other, it allows the observer to know what it is like to be in that pain. Knowing what it is like to be in these types of pain is likely to evoke a feeling of empathy. It is interesting that pain responders did not report significantly more empathy than participants who did not feel pain, which suggests that empathy is not a factor underpinning the experience of pain brought about by observation of others in pain. We have not specifically addressed the notion of empathy, as this has not been the direct focus of this thesis. We have focused on the extent to which we automatically adopt another's

perspective, presumably mediated by an automatic and implicit resonance system (Gallese, 2005; Keysars and Gazzola, 2009). It is however, plausible that empathy emerges as a reflexive and conscious evaluation of somebody else's pain, supported by the basic resonance afforded during embodied simulation of another's pain (Gallese, 2005; Gallese, Keysars, Rizzolatti, 2004; Keysars and Rizzolatti, 2009).

7.8 Strengths and limitations

Here we have demonstrated for the first time that in a significant minority of individuals pain is generated by observation of another in pain. We have linked this vicarious pain experience to areas of the brain coding the sensory discriminative aspects of pain, suggesting that pain generated by others in pain is similar to pain evoked by a more typical noxious stimulus (e.g. thermal or mechanical stimuli). A particular strength of this thesis is the inclusion in the fMRI study in Chapter Three of an 'emotional condition'. The ability to detract activation generated by an emotional scene from activation generated by a painful scene enables us to infer that the resulting activation is driven by the observation of pain and not by the emotional content of a painful image.

A limitation of the thesis is that we have not directly compared the areas of activation during pain generated by a noxious stimulus with pain generated by observation of others in pain. Participants were included as pain responders if they reported pain to at least 1/10 images. All of the data was included in the fMRI analyses despite the fact that pain was not reported to all images. It would be interesting to analyse only data for the images when pain was reported and compare it against the images that did not evoke pain.

This focus of this thesis has also not specifically addressed the role of empathy in the generation of this type of pain experience. Empathy is the emotional consequence of

observing others in pain, and, while it probably is necessary during the experience of pain generated by others in pain, it is unlikely to drive this experience. We have used a visual perspective taking task in Chapter Five to investigate the extent to which representations of self and other overlap. Future work could include higher level perspective taking mechanisms such as attributing mental states to others.

7.9 Conclusions and future directions

This thesis demonstrates for the first time that pain can be generated by observation of others in pain. Reports of pain are associated with the areas of the brain that underpin the sensory/discriminative aspects of pain processing, suggesting that reports of pain are underpinned by the same neural processes involved when processing a noxious stimuli. Pain responders are characterised by the ability to more readily take another person's perspective, adopt another person's body part into their body schema, experience anomalous perceptions other than pain, and have in general, have had more past injuries accompanied by pain than non responders. Observing another in pain is a valid method for inducing pain in the absence of noxious stimuli. Little is known about the exact time course of this pain experience and the transient nature of the pain. In order to look more closely at the time course, different imaging techniques such as magnetoencephalography (MEG) could be applied. Future work should also consider the inter-individual variability of pain experience in pain responders.

REFERENCES

Adolphs, R., Damasio, H., Tranel, D., Cooper, G., & Damasio, A.R. (2000). A role for somatosensory cortices in the visual recognition of emotion as revealed by three-dimensional lesion mapping. *Journal of Neuroscience*. 20, 2683-2690.

Aichhorn, M., Perner, J., Kronbichler, M., Staffen, W., & Ladurner, G. (2006). Do visual perspective tasks need theory of mind? *NeuroImage*. 30, 1059-1068.

Aldous, J.C., Ellam, G.A., Murray, V., & Pike, G. (1994). An outbreak of illness among schoolchildren in London: Toxic poisoning not mass hysteria. *Journal of Epidemiology & Community Health*. 48, 41-45.

Agnew, Z.K., Bhakoo, K.K., & Puri, B.K. (2007). The human mirror system: A motor resonance theory of mind-reading. *Brain Research Reviews*. 54, 286-293.

Angst, F., Brioschi, R., Main, C.J., Lehmann, S., & Aeschlimann, A. (2006). Interdisciplinary rehabilitation in fibromyalgia and chronic back pain: A prospective outcome study. *Journal of Pain*. 7(11), 807-815.

Armel, K.C., & Ramachandran, V.S. (2003). Projecting sensations to external objects: Evidence from skin conductance response. *Proceedings of the Royal Society of London: Biological*. 270, 1499-1506.

- Arzy, S., Thut, G., Mohr, C., Michel, C.M., Blanke, O. (2006). Neural basis of embodiment: Distinct contributions of temporoparietal junction and extrastriate body area. *Journal of Neuroscience*. 26(31), 8074-8081.
- Aspell, J.E., Langgenhager, B., & Blanke, O. (2009). Keeping in touch with one's self: Multisensory mechanisms of self-consciousness. *PLoS ONE*. 4(8), 6488.
- Austen, E.L., Soto-Faraco, S., Enns, J.T., & Kingstone, A. (2004). Mislocalizations of touch to a fake hand. *Cognitive, Affective, & Behavioural Neuroscience*. 4(2), 170-181.
- Avenanti, A. (2007). Pain in the absence of nociception: example from empathy. *Douleurs*. 8, 1S21-1S22.
- Avenanti, A., Buetti, D., Galati, G., & Aglioti, S.M. (2005) Transcranial magnetic stimulation highlights the sensorimotor side of empathy for pain. *Nature Neuroscience*. 8, 955-960.
- Avenanti, A., Pauello, I.M., Bufalari, I., & Aglioti, S.M. (2006). Stimulus-driven modulation of motor-evoked potentials during observations of others' pain. *NeuroImage*. 32, 316-324.
- Avenanti, A., Minio-Paluello, I., Bufalari, I., & Aglioti, S.M. (2009). The pain of a model in the personality of an onlooker: Influence of state-reactivity and personality traits on embodied empathy for pain. *NeuroImage*. 44, 275-283.
- Avenanti, A., Minio-Paluello, I., Sforza, A., & Aglioti, S.M. (2009). Freezing or escaping? Opposite modulations of empathic reactivity to the pain in others. *Cortex*. 45, 1072-1077.

- Bailey, P.E., & Henry, J.D. (2008). Growing less empathic with age: Disinhibition of the self-perspective. *Journals of Gerontology, Series B: Psychological Sciences and Social Sciences*, *63*, 219-226.
- Bandura, A., (1977). *Social Learning Theory*. New York: General Learning Press.
- Banissy, M.J., & Ward, J. (2007). Mirror touch synaesthesia is linked with empathy. *Nature Neuroscience*, *10*, 815-816.
- Bär, K., Gaser, C., Nenadic, I., & Sauer, H. (2002). Transient activation of a somatosensory area in painful hallucinations shown by fMRI. *NeuroReport*, *13*(6), 1-4
- Barsky, A.J., & Borus, J.F. (1999). Functional somatic syndromes. *Annals of Internal Medicine*, *130*(11), 910-921.
- Bass, C., & Murphy, M. (1991). Somatisation disorder in a British teaching hospital. *British Journal of Clinical Practice*, *45*, 237-244.
- Bass, C., Peveler, R., & House, A. (2001). Somatoform disorders: Severe psychiatric illnesses neglected by psychiatrists. *The British Journal of Psychiatry*, *179*, 11-14.
- Bayer, T.L., Baer, P.E., & Early, C. (1991) Situational and psychophysiological factors in psychologically induced pain. *Pain*, *44*, 45-50.

Bell, V., Halligan, P.W., & Ellis, H.D. (2006). The Cardiff Anomalous Perceptions Scale (CAPS): A new validated measure of anomalous perceptual experience. *Schizophrenia Bulletin*. 32(2), 366-377.

Bertelson, P., Vroomen, J., de Gelder, B., & Driver, J. (2000). The ventriloquist effect does not depend on the direction of deliberate visual attention. *Perception & Psychophysics*. 62, 321-332.

Birch, S.A., & Bloom, P. (2007). The curse of knowledge in reasoning about false beliefs. *Psychological Sciences*. 18, 382–386.

Blakemore, S.J., Bristow, D., Bird, G., Frith, C., & Ward, J. (2005). Somatosensory observations during the observation of touch and a case of vision-touch synaesthesia. *Brain*. 128,1571–1583.

Blakemore, S.J., Smith, J., Steel, R., Johnstone, E., & Frith, C.D. (2000). The perception of self-produced sensory stimuli in patients with auditory hallucinations and passivity experiences. Evidence for a breakdown in self-monitoring. *Psychological Medicine*. 30, 1131-1139.

Blanke, O., & Arzy, S. (2005). The out-of-body experience: Disturbed self-processing at the Temporo-Parietal junction. *The Neuroscientist*. 11(1), 16-24.

Bogaerts, K., Van Eylen, L., Wan, L., Bresseleers, J., Van Diest, I., De Peuter, S., . . . Van den Bergh, O. (2010). Distorted symptom perception in patients with medically unexplained symptoms. *Journal of Abnormal Psychology*. 119(1), 226-234.

Borsook, D., Moulton, E.A., Schmidt, K.F., & Beccera, L.R. (2007). Neuroimaging revolutionises therapeutic approaches to chronic pain. *Molecular Biology* 3, 25.

Botvinick, M., & Cohen, J.D. (1998). Rubber hand ‘feels’ what eyes can see. *Nature*. 391, 756.

Botvinick, M., Jha, A.P., Bylsma, L.M., Fabian, S.A., Soloman, P.E., & Prkachin, K.M. (2005) Viewing facial expressions of pain engages cortical areas involved in the direct experience of pain. *NeuroImage*. 25, 312-319.

Bradshaw, J.L., & Mattingley, J.B. (2001). Allodynia: a sensory analogue of motor mirror neurons in a hyperaesthetic patient reporting instantaneous discomfort to another’s perceived sudden minor injury? *Journal of Neurology, Neurosurgery and Psychiatry*. 70, 135–136.

Braithwaite, J.J., Samson, D., Apperly, I.A., Boglia, E., & Hulleman, J. (in press). Cognitive correlates of the Out-of-Body-Experience (OBE) in the psychologically normal population: Evidence for an increased role of temporal-lobe instability, body-distortion processing, and impairments in own-body transformations. *Cortex*.

Brand, P., & Yancey, P. (1997). *The gift of pain: Why we hurt and what we can do about it*. Michigan: Zondervan.

- Brugger, P. (2002). Reflective mirrors: Perspective-taking in autoscopic phenomena. *Cognitive Psychology*, 7(3), 179-194.
- Bufalari, I., Aprile, T., Avenanti, A., Di Russo, F., & Aglioti, S.M. (2007). Empathy for pain and touch in the human cerebral cortex. *Cerebral Cortex*, 17, 2553-2561.
- Butler, C.C., Evans, H.M., Greaves, D., & Simpson, S. (2004). Medically unexplained symptoms: The Biopsychosocial Model found wanting. *Journal of the Royal Society of Medicine*, 97, 219-222.
- Calder, A.J., Keane, J., Manes, F., Antoun, N., & Young, A.W. (2000). Impaired recognition and experience of disgust following brain injury. *Nature Neuroscience*, 3, 1077-1078.
- Capelari, E.D., Uribe, C., & Brasil-Neto, J.P. (2009). Feeling pain in the rubber hand: Integration of visual, proprioceptive, and painful stimuli. *Perception*, 38(1), 92-99.
- Carson, D.A., Chen, P.P., Fox, R.I., Kipps, T.J., Jirik, F., Goldfien, R.D., . . . Fong, S. (1987). Rheumatoid factor and immune networks. *Annual Review of Immunology*, 5, 109-126.
- Chen, Z., Williams, K.D., Fitness, J., & Newton, N.C. (2008). When hurt will not heal: Exploring the capacity to relive social and physical pain. *Psychological Science*, 19(8), 789-795.

- Cheng, Y., Lee, P., Yang, C., Lin, C., Hung, D., & Decety, J. (2008). Gender differences in the Mu rhythm of the human mirror-neuron system. *PLoS ONE*. 3(5), 2113.
- Cheng, Y., Lin, C., Liu, H., Hsu, Y., Lim, K., Hung, D., & Decety, J. (2007). Expertise modulates pain perception in others. *Current Biology*. 17(19), 1708-1713.
- Choi, D.S., Choi, D.Y., Whittington, R.A., & Nedeljkovic, S.S. (2007). Sudden amnesia resulting in pain relief: The relationship between memory and pain. *Pain*. 132, 206-210.
- Classen, W., Feingold, E., & Netter, P. (1983). Influence of sensory suggestibility on treatment outcome in headache patients. *Neuropsychobiology*. 10, 44-47.
- Coghill, R.C., McHaffie, J.G., & Yen, Y.F. (2003). Neural correlates of interindividual differences in the subjective experience of pain. *Proceedings of the National Academy of Sciences of the United States of America*. 100(14). 8538-8542.
- Constantini, M., & Haggard, P. (2007). The rubber hand illusion: Sensitivity and reference frame for body ownership. *Consciousness and Cognition*. 16, 229-240.
- Crombez, G., Eccleston, C., Baeyens, F., Eelen, P. (1996). The disruptive nature of pain: An experimental investigation. *Behaviour Research and Therapy*. 34, 911-918.
- Danziger, N., Prkachin, K.M., & Willer, J. (2006). Is pain the price of empathy? The perception of others' pain in patients with congenital insensitivity to pain. *Brain*. 129, 2494-2507.

- Dapretto, M., Davies, M.S., Pfeifer, J.H., Scott, A.A., Sigman, M., Bookheimer, S.Y., & Iacoboni, M. (2006). Understanding emotions in others: Mirror neuron dysfunction in children with autistic spectrum disorders. *Nature Neuroscience*. 9, 28-30.
- Davis, M.H.A. (1980). Multidimensional approach to individual differences in empathy. *JSAS Catalogue of Selected Documents in Psychology*. 10, 85.
- Da Costa, D., Dobkin, P.L., Fitzcharles, M.A., Fortin, P.R., Beaulieu, A., Zummer, M., . . . Clarke, A.E. (2000). Determinants of health status in fibromyalgia: A comparative study with systemic lupus erythematosus. *Journal of Rheumatology*. 27(2), 365-372.
- De Pascalis, V., Chiaradia, C., & Carotenuto, E. (2002). The contribution of suggestibility and expectation to placebo analgesia phenomenon in an experimental setting. *Pain*. 96, 393-402.
- Decety, J., & Chaminade, T. (2003). When the self represents the other: A new cognitive neuroscience view on psychological identification. *Consciousness and Cognition*. 12, 577-596.
- Decety, J., & Lamm, C. (2007). The role of the right temporoparietal junction in social interaction: How low-level computational processes contribute to meta-cognition. *The Neuroscientist*. 13, 580-593.

- Decety, J., Yang, C.Y., & Cheng, Y. (2010). Physicians down-regulate their pain empathy response: An event-related brain potential study. *NeuroImage*. 50(4), 1676-1682.
- Derbyshire, S.W.G. (2006). Can foetuses feel pain? *British Medical Journal*. 332, 909-912.
- Derbyshire, S.W.G., Whalley, M.G., Stenger, V.A., & Oakley, D.A. (2004). Cerebral activation during hypnotically induced and imagined pain. *NeuroImage*. 23, 392-401.
- Derbyshire, S.W.G., Whalley, M.G., & Oakley, D.A. (2009). Fibromyalgia pain and its modulation by hypnotic and non-hypnotic suggestion: An fMRI analysis. *European Journal of Pain*. 13,542-550.
- Deyo, R.A., Battie, M., Beurskens, A.J., Bombardier, C., Croft, P., & Koes, B. (1999). Outcome measures for low back pain research. A proposal for standardized use correction. *Spine*. 23, 2003–2013.
- Dieguez, S., Mercier, M.R., Newby, N., & Blanke, O. (2009). Feeling numbness for someone else. *Current Biology*, 24 (19), R1108-R1109
- Drummer, T., Picot-Annand, A., Neal, T., & Moore, C. (2009). Movement and the rubber hand illusion. *Perception*. 38(2), 271-280.
- Duque, J., Mazzocchio, R., Dambrosia, J., Murase, N., Olivier, E., & Cohen, L. G. (2005). Kinematically specific interhemispheric inhibition operating in the process of generation of a voluntary movement. *Cerebral Cortex*. 15, 588–593.

- Ehrsson, H.H., Holmes, N.P., & Passingham, R.E. (2005). Touching a rubber hand: Feeling of body ownership is associated with activity in multisensory brain areas. *Journal of Neuroscience*. 25, 10564–10573.
- Eisenberger, N.I., Lieberman, M.D., & Williams, K.D. (2003). Does rejection hurt? An fMRI study of social exclusion. *Science*. 302, 290-292.
- Epley, N., Keysar, B., Van Boven, L., Gilovich, T. (2004). Perspective taking as egocentric anchoring and adjustment. *Journal of Personality and Social Psychology*. 87, 327–39.
- Epley, N., Morewedge, C., & Keysar, B. (2004). Perspective taking in children and adults: Equivalent egocentrism but differential correction. *Journal of Experimental Social Psychology*. 40, 760-768.
- Fan, Y., & Han, S. (2008). Temporal dynamic of neural mechanisms involved in empathy for pain: An event-related brain potential study. *Neuropsychologia*. 46, 160-173.
- Farina, S., Tinazzi, M., Le Pera, D., & Valeriani, M. (2003). Pain-related modulation of the human motor cortex. *Neurological Research*. 25, 130-142.
- Fassbender, K., Samborsky, W., Kellner, M., Muller, W., & Lautenbacher, S. (1997). Tender points, depressive and functional symptoms: Comparison between fibromyalgia and major depression. *Clinical Rheumatology*. 16, 76-79.

- Ffytche, D.H., Howard, R.J., Brammer, M.J., David, A., Woodruff, P., & Williams, S. (1998). The anatomy of conscious vision: An fMRI study of visual hallucinations. *Nature Neuroscience*. 1, 738-742.
- Fisher, J.P., Hassan, D.T., & O'Connor, N. (1995). Minerva. *British Medical Journal*. 310, 70.
- Fitzgibbon, B.M., Giummarra, M.J., Georgiou-Karistianis, N., Enticott, P.G., & Bradshaw, J.L. (2010). Shared pain: From empathy to synaesthesia. *Neuroscience and Biobehavioural Reviews*. 34(4), 500-512.
- Flor, H. (2000). The functional organization of the brain in chronic pain. *Progress in Brain Research*. 129, 313-322.
- Flor, H. (2003). Cortical reorganisation and chronic pain: Implications for rehabilitation. *Journal of Rehabilitation Medicine*. S41,66-72.
- Flykt, A. (2006). Preparedness for action: Responding to the snake in the grass. *American Journal of Psychology*. 119, 29-44.
- Fogassi, L., Ferrari, P.F., Gesierich, B., Rozzi, S., Chersi, F., Rizzolatti, G. (2005). Parietal lobe: From action organization to intention understanding. *Science*. 308, 662-667.
- Freedberg, D., & Gallese, V. (2007). Motion, emotion, and empathy in esthetic experience. *Trends in Cognitive Sciences*. 11, 197-203.

Frith, C. (1996). What are the implications of experiential abnormalities for the neurobiology of Schizophrenia. *British Medical Bulletin*. 52, (2), 618-623.

Gallese, V. (2001). The “Shared Manifold” Hypothesis: From mirror neurons to empathy. *Journal of Consciousness Studies*. 8(5-7), 33-50.

Gallese, V. (2005). Embodied stimulation: From neurons to phenomenal experience. *Phenomenology and the Cognitive Sciences*. 4, 23-48.

Gallese, V., & Goldman, A. (1998). Mirror neurons and the simulation theory of mind-reading. *Trends in Cognitive Sciences*. 12, 493, 501.

Gallese, V., Keysers, C., & Rizzolatti, G. (2004). A unifying view of the basis of social cognition. *Trends in Cognitive Science*. 8, 396–403.

Gazzola, V. & Keysars, K. (2009). The execution and observation of actions share motor and somatosensory voxels in all tested subjects: Single subject analyses of unsmoothed subject data. *Cerebral Cortex*. 19, 1239-1255.

Gloor, P. (1990). Experiential phenomena of temporal lobe epilepsy. *Brain*. 113(6), 1673-1694.

Grahek, N. (2001). *Feeling pain and being in pain*. Cambridge, Massachusetts: Massachusetts Institute of Technology Press.

Giummarra, M.J., & Bradshaw, J.L. (2008) Synaesthesia for pain: Feeling pain with another.

In: Pineda, J.A., (Ed.), *Mirror neuron systems: The role of mirroring processes in social cognition*. Totowa: USA Humana Press Inc.

Godinho, F., Magnin, M., Frot, M., Perchet, C., & Garcia-Larrea, L. (2006). Emotional modulation of pain: Is it the sensation or what we recall? *Journal of Neuroscience*. 26(44), 11454-11461.

Goh, K.T. (1987). Epidemiological enquiries into a school outbreak of an unusual illness. *International Journal of Epidemiology*. 16, 265-270.

Goubert, L., Craig K.D., Vervoort, T., Morley, S., Sullivan, M.J., Williams, A.D., . . .

Crombez, G. (2005). Facing others in pain: The effects of empathy. *Pain*. 118, 285-288.

Hadjistavropoulos, T., & Craig, K.D. (2002). A theoretical framework for understanding self-report and observational measures of pain: a communications model. *Behaviour Research and Therapy*. 40(5), 551-570.

Haggard, P., & Tsakiris, M. (2005). The rubber hand illusion revisited: Visuotactile integrations and self-attribution. *Journal of Experimental Psychology: Human Perception and Performance*. 31(1), 80-91.

Halverson, H., Crooks, J., LaHart, D.A., & Farrell, K.P. (2008). An outbreak of itching in an elementary school – A case of mass psychogenic response. *Journal of School Health*. 78(5), 294-297.

Hamilton, A., Brindley, R., & Frith, U. (2009). Visual perspective taking impairment in children with autistic spectrum disorder. *Cognition*. 113(1), 37-44.

Hardcastle, V. (1997). *The myth of pain*. Cambridge, Massachusetts: The Massachusetts Institute of Technology Press.

Hauk, O., Johnsrude, I., & Pulvermuller, F. (2004). Somatotopic representation of action words in human motor and premotor cortex. *Neuron*. 41, 301-307.

Henriksson, C., & Burckhardt, C. (1996). Impact of Fibromyalgia on everyday life – A study of women in the USA and Sweden. *Disability and Rehabilitation*. 18, 241-248.

Hobson, A.R, Furlong, P.L., Worthen, S.F., Hillebrand, A., Barnes, G.R., Singh, K.D., Aziz, Q. (2005). Real-time imaging of human cortical activity evoked by painful oesophageal stimulation. *Gastroenterology*. 128, 610-619.

Hutchison, W.D., Davis, K.D., Lozano, A.M., Tasker, R.R., & Dostrovsky, J.O. (1999). Pain-related neurons in the human cingulate cortex. *Nature Neuroscience*. 2, 403–405.

Iacoboni, M., & Dapretto, M. (2006). The mirror neuron system and the consequences of dysfunction. *Nature Reviews Neuroscience*. 7(12), 942-951.

- Ishida, H., Nakajima, K., Inase, M., & Murata, A. (2009) Shared mapping of own and others' bodies in visuotactile bimodal area of monkey parietal cortex. *Journal of Cognitive Neuroscience*. 22(1), 83-96.
- Jackson, P.L., Brunet, E., Meltzoff, A.N., & Decety, J. (2006). Empathy examined through the neural mechanisms involved in imagining how I feel versus how you feel pain. *Neuropsychologia*. 44, 752-761.
- Jackson, P.L., Meltzoff, A.N., & Decety, J. (2005). How do we perceive the pain of others? A window into the neural processes involved in empathy. *Neuroimage*. 24, 771-769.
- Jackson, P.L., Rainville, P., & Decety, J. (2006). To what extent do we share the pain of others? Insight from the neural basis of empathy. *Pain*. 125, 5-9.
- Jantsch, H.H., Gawlitza, M., Geber, C., Baumgartner, U., Kramer, H.H., Magerl, W., . . . Birklein, F. (2009). Explicit episodic memory for the sensory-discriminative components of capsaicin-induced pain: immediate and delayed ratings. *Pain*. 143, 97-105.
- Jeannerod, M. (1997). *The cognitive neuroscience of action*. Oxford: Wiley-Blackwell.
- Jeannerod, M. (2004). Visual and action cues contribute to the self-other distinction. *Nature Neuroscience*. 7(5), 422-423.

- Jeannerod, M., & Anquetil, T. (2008). Putting oneself in the perspective of the other: A framework for self-other differentiation. *Social Neuroscience*. 3(3-4), 356-367.
- Johns, L.C., Nazroo, J.Y., Bebbington, P., & Kuipers, E. (2002). Occurrence of hallucinatory experiences in a community sample and ethnic variations. *British Journal of Psychiatry*. 180, 174-178.
- Jones, E., & Wessely, S. (2003). PTSD: the history of a concept. *Psychiatry*. 2, 1-4.
- Jones, T.F., Craig, A.S., Hoy, D., Gunter, E.W., Ashley, D.L., Barr, D.B., . . . Schaffner, W. (2000). Mass psychogenic illness attributed to toxic exposure at a high school. *New England Journal of Medicine*. 342(2), 96-100.
- Kain, Z.N., Sevarino, F., Alexander, G.M., Pincus, S., & Mayes, L.C. (2000). Preoperative anxiety and postoperative pain in women undergoing hysterectomy: A repeated measures design. *Journal of Psychosomatic Research*. 49, 417-422.
- Karst, M., Rahe-Meyer, N., Guedek, A., Hoy, L., Borsutzky, M., & Passie, T. (2005). Abnormality in the self-monitoring mechanism in patients with Fibromyalgia and Somatoform Pain Disorder. *Psychosomatic Medicine*. 67, 111-115.
- Katz, J., & Melzack, R. (1990). Pain 'memories' in phantom limbs: Review and clinical observations. *Pain*. 43(3), 319-336.

- Kelly, S., Lloyd, D., Nurmikko, T., & Robert, N. (2007) Retrieving autobiographical memories of painful events activates the anterior cingulate cortex and inferior frontal gyrus. *The Journal of Pain*. 8(4), 307-314.
- Kessler, K., & Thomson, L.A. (2010). The embodied nature of spatial perspective taking: Embodied transformation versus sensorimotor interference. *Cognition*. 114, 72-88.
- Keysers, C., & Gazzola, V. (2006). Towards a unifying neural theory of social cognition. *Progress in Brain Research*. 156, 383--406.
- Keysers, C., & Gazzola, V. (2007). Integrating simulation and theory of mind: From self to social cognition. *Trends in Cognitive Sciences*. 11, 194--196.
- Keysers, C., & Gazzola, V. (2009). Expanding the mirror: Vicarious activity for actions, emotions, and sensations. *Current Opinion in Neurobiology*. 19(6), 666-671.
- Keysers, C., Wicker, B., Gazzola, V., Anton, J.L., Fogassi, L., & Gallese. (2004). A touching sight: SII/PV activation during the observation and experience of touch. *Neuron*. 42, 335-346.
- Kirkwood, C.R., Clure, H.R., Brodsky, R., Gould, G.H., Knaak, R., . . . Romeo, S. (1982). The diagnostic content of family practice: 50 most common diagnoses recorded in the WAMI community practices. *Journal of Family Practice*. 15(3), 485-492.
- Kirsch, I., & Lynn, S.J. (1997). Hypnotic involuntariness and the automaticity of everyday life. *American Journal of Clinical Hypnosis*. 40, 329-348.

Kirwilliam, S.S., & Derbyshire, S.W.G. (2008). Increased bias to report heat or pain following emotional priming of pain-related fear. *Pain*. 137, 60-65.

Kofler, M., Glocker, F.X., Leis, A.A., Seifert, C., Wissel, J., Kronenberg, M.F., & Fuhr, P. (1998). Modulation of upper extremity motoneurone excitability following noxious finger tip stimulation in man: A study with transcranial magnetic stimulation. *Neuroscience Letters*. 246 (2), 97-100.

Koutantki, M., Pearce, S.A. and Oakley, D. A. (1998). The relationship between gender and family history with pain and current pain experience and awareness of others in pain. *Pain*. 77 (1), 25-31.

Kroenke, K., & Swindle, R. (2001). Cognitive-behavioural therapy for somatisation and symptom syndromes: A critical review of controlled clinical trials. *Psychotherapy and Psychosomatics*. 69(4), 205-215.

Kulkarni, B., Bentley, D.E., Elliott, R., Youell, P., Watson, A., Derbyshire, S.W.G., . . . Jones, A. (2005). Attention-dependent processing of nociception in the human brain. *European Journal of Neuroscience*. 21, 3133-3142.

Kuhn, K.A., Kulik, L., Tomooka, B., Braschler, K.J., Arend, W.P., Robinson, W.H. & Holers, V.M. (2006). Antibodies against citrullinated proteins enhance tissue injury in experimental autoimmune arthritis. *Journal of Clinical Investigation*. 116(4), 961-973.

- Lamm, C., Batson, C.D., & Decety, J. (2007). The neural basis of human empathy – Effects of perspective-taking and cognitive appraisal: An event-related fMRI study. *Journal of Cognitive Neuroscience*. 19, 42-58.
- Lamm, C., Nusbaum, H.C., Meltzoff, A.N., & Decety, J. (2007). What are you feeling? Using functional magnetic resonance imaging to assess the modulation of sensory and affective responses during empathy for pain. *PLoS ONE*. 2(12), e1292.
- Lang, P.J., Bradley, M.M., & Cuthbert, B.N. (1999). *International affective picture system (IAPS): Technical manual and affective ratings*. Gainesville: University of Florida, Center for Research in Psychophysiology.
- Lawrence, E.J., Shaw, P., Baker, D., Baron-Cohen, S., & David, A.S. (2004). Measuring empathy – Reliability and validity of the empathy quotient. *Psychological Medicine*. 34, 911-919.
- Leis, A.A., Stokic, D.S., Fuhr, P., Kofler, M., Kronenberg, M.F., Wissel, J., . . . Štetkárová, I. (2000). Nociceptive fingertip stimulation inhibits synergistic motoneuron pools in the human upper limb. *Neurology*. 55, 1305-1309.
- Lennox, B.R., Park, S.B., Medley, I., Morris, P.G., & Jones, P.B. (2000). The functional anatomy of auditory hallucinations in schizophrenia. *Psychiatry Research*. 100(1), 13-20.

Le Pera, D., Graven-Nielsen, T., Valeriani, M., Oliviero, A., Di Lazzaro, V., Tonali, P.A., & Arendt-Nielsen, L. (2001). Inhibition of motor system excitability at cortical and spinal level by tonic muscle pain. *Clinical Neurophysiology*. *112*, 1633-1641.

Levy, R.L., Jones, K.R., Whitehead, W.E., Feld, S.I., Talley, N.J., & Corey, L.A. (2001). Irritable bowel syndrome in twins: heredity and social learning both contribute to etiology. *Gastroenterology*. *121*(4), 799-804.

Linton, S.J., Buer, N., Vlaeyen, J., & Hellising, A. (2000). Are fear-avoidance beliefs related to the inception of an episode of back pain? A prospective study. *Psychology and Health*, *14*, 1051–1059.

Loggia, M.L., Mogil, J.S., & Bushnell, M.C. (2008). Empathy hurts: Compassion for another increases both sensory and affective components of pain. *Pain*. *136*, 168-176.

Lombardo, M.V., Chakrabarti, B., Bullmore, E.T., Sadek, S.A., Pasco, G., Wheelwright, S.J., . . . Baron-Cohen, S. (2010). Atypical neural self-representation in autism. *Brain*. *133*(2), 611-624.

MacDonald, G., & Leary, M.R. (2005). Why does social exclusion hurt? *Psychology Bulletin*. *131*, 202-223.

Makin, T.R., Holmes, N.P., & Ehrsson, H.H. (2008). On the other hand: Dummy hands and peripersonal space. *Behavioural Brain Research*. *191*(1), 1-10.

- Martel, M.O., Thibault, P., Roy, C., Catchlove, R., & Sullivan, M.J.L. (2008). Contextual determinants of pain judgements. *Pain*. 139(3), 562-568.
- Mayou, R., Bass, C., & Sharpe, M. (1995). Overview of epidemiology, classification, and aetiology. *Treatment of Functional Somatic Symptoms*. 42-65.
- Mayou, R., Kirmayer, L.J., Simon, G., Kroenke, K., & Sharpe, M. (2005). Somatoform disorders: Time for a new approach in DSM-V. *American Journal of Psychiatry*. 162(5), 847-855.
- Mazzoni, G., Foan, L., Hyland, M.E., & Kirsch, I. (2010). The effects of observation and gender on psychogenic symptoms. *Health Psychology*. 29(2), 181-185.
- McCabe, C.S., Haigh, R.C., Halligan, P.W. & Blake, D.R. (2005). Simulating sensory-motor incongruence in healthy volunteers: Implications for a cortical model of pain. *Rheumatology*. 44(4), 509-516.
- McCabe, C.S., Haigh, R.C., Ring, E.F.J., Halligan, P.W., Wall, P.D., & Blake, D.R. (2003). A controlled pilot study of the utility of mirror visual feedback in the treatment of complex regional pain syndrome (type 1). *Rheumatology*. 42(1), 97-101.
- McCabe, C.S., Saidi, M., & Priebe, S. (2007). Patient-reported outcomes in schizophrenia. *The British Journal of Psychiatry*. 191, s21-s28.

- McCracken, L.M., Zayfert, C. & Gross, R.T. (1992). The Pain Anxiety Symptoms Scale: Development and validation of a scale to measure fear of pain. *Pain*. 50,67–73.
- McGilchrist, I., & Cutting, J. (1995). Somatic delusions in schizophrenia and the affective psychoses. *The British Journal of Psychiatry*. 167, 350-361.
- Mehling, W.E., Gopisetty, V., Daubenmier, J., Price, J., Hecht, F.H., & Stewart, A. (2009). Body awareness, construct and self-report measures. *PLoS One*. 4(5), e5614.
- Melzack, R. (1987). The short-form McGill Pain Questionnaire. *Pain*. 30, 191-197.
- Melzack, R. (1990). Phantom limbs and the concept of a neuromatrix. *Trends in Neuroscience* 13:8892.
- Melzack, R. (2001). Pain and the neuromatrix in the brain. *Journal of Dental Education*. 65(12), 1378-1382.
- Melzack, R., & Katz, J. (1994). Pain measurement in persons in pain. In Wall, P.D., & Melzack, R. (Eds.), *Textbook of Pain*. London: Churchill Livingstone.
- Melzack, R., & Wall, P.D. (1965). Pain mechanisms: A new theory. *Science*. 150(699). 971-979.
- Melzack, R., Wall, P.D., & Tye, T.C. (1982). Acute pain in an emergency clinic – Latency of onset and descriptor patterns related to different injuries. *Pain*. 14(1), 33-43.

Merskey, H. (1991). The definition of pain. *European Journal of Psychiatry*, 6, 153-159.

Merskey, H.M., & Bogduk, N. (1994). *Classification of chronic pain*. 2nd ed. Seattle: IASP Press.

Michelon, P., & Zacks, J.M. (2006). Two kinds of visual perspective taking. *Perception & Psychophysics*. 68, 327-337.

Milan, M.J. (2002). Descending control of pain. *Progress in Neurobiology*. 66, 355-474.

Militerni, R., Bravaccio, C., Falco, C., Puglisi-Allegra, S., Passucci, T., Fico, C. (2000). Pain reactivity in children with autistic disorder. *Journal of Headache Pain*. 1, 53-56.

Minio-Paluello, I., Baron-Cohen, S., Avenanti, A., Walsh, A. V., & Aglioti, S.M. (2009). Absence of embodied empathy during pain observation in Aspergers Syndrome. *Biological Psychiatry*. 65, 55-62.

Miron, D., Duncan, G.H., & Bushnell, M.C. (1989). Effects of attention on the intensity and unpleasantness of thermal pain. *Pain*. 39, 345-352.

Mogg, K., Bradley, B.P., Miles, F., & Dixon, R. (2004). Time course of attentional bias for threat scenes: Testing the vigilance-avoidance hypothesis. *Cognition and Emotion*. 18(5), 689-700.

- Morley, S. (1993). Vivid Memory for 'Everyday' Pains. *Pain*. 55, 55-62.
- Morrison, I., & Downing, I. (2007). Organisation of felt and seen pain responses in anterior cingulate cortex. *NeuroImage*. 37(2), 642-651.
- Morrison, I., Lloyd, D., Di Pellegrino, G., & Roberts, N. (2004). Vicarious responses to pain in anterior cingulate cortex: Is empathy a multisensory issue? *Cognitive, Affective & Behavioural Neuroscience*. 4,270–278.
- Moseley, G.L., Olthof, N., Venema, A., Don, S., Wijers, M., Gallace, A., & Spence, C. (2008). Psychologically induced cooling of a specific body part caused by the illusory ownership of an artificial counterpart. *Proceedings of the National Academy of Sciences*. 105, 13169-13173.
- Mussap, A.J., & Salton, N. (2006). A "rubber-hand" illusion reveals a relationship between perceptual body image and unhealthy body change. *Journal of Health Psychology*. 11, 627-639.
- Newcombe, N. (1989). Development of spatial perspective taking. In H.W. Reese (Ed.), *Advances in child development and behaviour*. San Diego, CA: Academic Press.
- Niedenthal, P.M. (2007). Embodying emotion. *Science*. 316, 1002-1005.
- Nimnuan, C., Hotopf, M., & Wessely, S. (2001). Medically unexplained symptoms: An epidemiological study in seven specialities. *Journal of Psychosomatic Research*. 51, 361-367.

Oberman, L.M., & Ramachandran, V.S. (2007). Evidence for deficits in mirror neuron functioning, multisensory integration, and sound-form symbolism in autism spectrum disorders. Invited submission to special issue of *Social Neuroscience* on Interpersonal Sensitivity.

Ogawa, S., Lee, T.M., Kay, A.R., & Tank, D.W. (1990). Brain Magnetic Resonance Imaging with contrast dependent on blood oxygenation. *Proceedings of the National Academy of Sciences*. 87, 9868–9872.

Ohayon, M.M. (2000). Prevalence of hallucinations and their pathological associations in the general population. *Psychiatry Research*. 97(2-3), 153-164.

Oswald, P.A. (1996). The effects of cognitive and affective perspective-taking on empathic concern and altruistic helping. *Journal of Social Psychology*. 136, 613-623.

Pavani, F., Spence, C., & Driver, J. (2000). Visual capture of touch: Out-of-the-body experiences with rubber gloves. *Psychological Science*. 11, 353-359.

Peled, A., Ritsner, M., Hirschmann, S., Geva, A.B., & Modai, I. (2000). Touch feel illusion in schizophrenic patients. *Biological Psychiatry*. 48(11), 1105-1108.

Pennebaker, J.W. (1982). *The Psychology of Physical Symptoms*. Berlin: Springer-Verlag.

- Peralta, V., & Cuesta, M.J. (1990). Síntomas esquizofrénicos positivos y negativos: un reanálisis del modelo dicotómico de la esquizofrenia. *Actas Luso Esp Neurol Psiquiatr.* 18, 266-273.
- Persinger, M.A., & Makarec, K. (1987). Temporal lobe signs and correlative behaviours displayed by normal populations. *Journal of General Psychology.* 114, 179-195.
- Peyron, R., Laurent, B., & Garcia-Larrea, L. (2000). Functional imaging of brain responses to pain: A review and meta-analysis. *Neurophysiologie Clinique.* 30, 263-288.
- Ploner, M., Gross, J., Timmermann, L., & Schnitzler, A. (2006). Pain processing is faster than tactile processing in the human brain. *The Journal of Neuroscience.* 26(42), 10879-10882.
- Ploghaus, A., Narain, C., Beckmann, C.F., Clare, S., Bantick, S., Wise, R., & Tracey, I. (2001). Exacerbation of pain by anxiety is associated with activity in a Hippocampal network. *Journal of Neuroscience.* 21, 9896-9903.
- Preston, S.D., & De Waal, F.B.M. (2002). Empathy: Its ultimate and proximate bases. *Behavioural Brain Science.* 25, 1-20.
- Price, D.D. (2000). Psychological and neural mechanisms of the affective dimension of pain. *Science.* 288, 1769-1772.

- Prkachin, K.M., Solomon, P., Hwang, T., & Mercer, S.R. (2001). Does experience affect judgements of pain behaviour? Evidence from relatives of pain patients and health-care providers. *Pain Research and Management*. 6, 105-112.
- Rainville, P., Duncan, G.H., Price, D.D., Carrier, B., & Bushnell, M.C. (1997). Pain affect encoded in human anterior cingulate but not Somatosensory cortex. *Science*. 277, 968-971.
- Ramachandran, V.S., & Hubbard, E.M. (2001). Synaesthesia: A window into perception, thought and language. *Journal of Consciousness Studies*. 8(12), 3-34.
- Renn, C.L., & Dorsey, S.G. (2005). The physiology and processing of pain: A review. *AACN Clinical Issues*. 16(3), 277-290.
- Ricci, J.A., Chee, E., Lorandean, A.L., & Berger, J. (2007). Fatigue in the U.S. workforce: Prevalence and implications for lost productive work time. *Journal of Occupational and Environmental Medicine*. 49(1), 1-10.
- Rizzolatti, G., Fogassi, L., & Gallese, V. (2001). Neurophysiological mechanisms underlying the understanding and imitation of action. *Nature Reviews Neuroscience*. 2, 661-670.
- Rhudy, J.L., & Meager, M.W. (2000). Fear and anxiety: Divergent effects on human pain thresholds. *Pain*. 84, 65-75.
- Rizzolatti, G., Fadiga, L., Gallese, V., & Fogassi, L. (1996). Premotor cortex and the recognition of motor actions. *Cognitive Brain Research*. 3 (2), 131-141.

Rizzolatti, G., Fogassi, L., & Gallese, V. (2001). Neurophysiological mechanisms underlying the understanding and imitation of action. *Nature Reviews Neuroscience*. 2, 661–670.

Ruo, B., Rumsfeld, J.S., Hlatky, M.A., Liu, H., Browner, W.S., & Whooley, M.A. (2003). Depressive symptoms and health-related quality of life: The heart and soul study. *The Journal of the American Medical Association*. 290(2), 215-221.

Saarela, M.V., Hlushchuk, Y., Williams, A.C., Schurmann, M., Kalso, E., & Hari, R. (2007). The compassionate brain: Humans detect intensity of pain from another's face. *Cerebral Cortex*. 17(1), 230-237.

Sailer, A., Molnar, G.F., Cunic, D.I., & Chen, R. (2004). Effects of peripheral sensory input on cortical inhibition in humans. *The Journal of Physiology*. 544(2), 617-629.

Salomons, T.V., Osterman, J.E., Gagliese, L., & Katz, J. (2004). Pain flashbacks in Post-Traumatic Stress Disorder. *Clinical Journal of Pain*. 20, 83-87.

Samson, D., Apperly, I.A., Braithwaite, J.J., Andrews, B.J., & Bodley Scott, S.A. (in press). Seeing it their way: Evidence for rapid involuntary computation of what other people see. *Journal of Experimental Psychology: Human Perception & Performance*.

Samson, D., Apperly, I.A., Chiavarino, C., & Humphreys, G.W. (2004). The left temporo-parietal junction is necessary for representing someone else's belief. *Nature Neuroscience*. 7, 499-500.

Samson, D., Apperly, I.A., Kathirgamanathan, U., & Humphreys, G.W. (2005). Seeing it my way: A case of selective deficit in inhibiting self-perspective. *Brain*. 128, 1102-1111.

Sawamoto, N., Honda, M., Okada, T., Hanakawa, T., Kanda, M., Fukuyama, H., . . .

Shibasaki, H. (2000). Expectation of pain enhances responses to nonpainful somatosensory stimulation in the anterior cingulate cortex and parietal operculum/posterior insula: An event-related functional magnetic resonance imaging study. *The Journal of Neuroscience*. 20(19), 7438-7445.

Schoth, D., & Liossi, C. (2010). Attentional bias toward pictorial representations of pain in individuals with chronic headache. *Journal of Pain*. 26(3), 244-250.

Schweiger, A., & Parducci, A. (1981). Nocebo: The psychologic induction of pain. *The Pavlovian Journal of Biological Science*. 16, 140-143.

Schweinhardt, P., Sauro, K.M., & Bushnell, M.C. (2008). Fibromyalgia: A disorder of the brain? *Neuroscientist*. 14(5), 415-421.

Singer, T., Seymour, B., O'Doherty, J., Kaube, H., Dolan, R.J., & Frith, C. (2004). Empathy for pain involves the affective but not sensory components of pain. *Science*. 303, 1157-1162.

Smith, G.R., Monson, R.A., & Ray, D.C. (1986). Patients with multiple unexplained symptoms. Their characteristics, functional health and health care utilisation. *Archives of Internal Medicine*. 146, 69-72.

Smith, S.M., Jenkinson, M., Woolrich, M.W., Beckmann, C.F., Behrens, T.E.J., Johansen-Berg, H., . . . Matthews, P.M. (2004). Advances in Functional and Structural MR Image analysis and implementation as FSL. *NeuroImage*. 23, 208-219.

Söderberg, S., & Lundman, B. (2001). Transitions experienced by women with Fibromyalgia. *Health Care for Women International*. 22(7), 617-631.

Stamenov, N.I., and Gallese, V. (2002). *Mirror neurons and the evolution of brain and language*. Amsterdam: John Benjamins Publishing Company.

Stefan, K., Cohen, L.G., Duque, J., Mazzacchio, R., Celnik, P., Sawaki, L., & Classen, J. (2005). Formation of a mirror memory by action observation. *The Journal of Neuroscience*. 25(41), 9339-9346.

Struewing, J.P., & Gray, G.C. (1990). Epidemic of respiratory complaints exacerbated by mass psychogenic illness in a military recruit population. *American Journal of Epidemiology*. 132, 1120-1129.

Sullivan, M.J.L., Martel, M.O., Tripp, D.A., Savard, A., & Crombez, G. (2006). Catastrophic thinking and heightened perception of pain in others. *Pain*. 123(1), 37-44.

Sullivan, M.J.L., Thorn, B., Haythornthwaite, J.A., Keefe, F., Martin, M., Bradley, L.A., & Lefebvre, J.C. (2001). Theoretical perspectives on the relation between catastrophising and pain. *Clinical Journal of Pain*. 17, 52-64.

Thakkar, K.N., & Park, S. (in press). Empathy, schizotypy, and visuospatial transformations. *Cognitive Neuropsychiatry*.

Théoret, H., Halligan, E., Kobayashi, M., Fregni, F., Tager-Flusberg, H., & Pascual-Leone, A. (2005). Impaired motor facilitation during action observation in individuals with autism spectrum disorder. *Current Biology*. 159(3), R84-R85.

Tsakiris, M., Carpenter, L., James, D., & Fotopoulou, A. (2010). Hands only illusion: Multisensory integration elicits sense of ownership for body parts but not for non-corporeal objects. *Experimental Brain Research*. 204(3), 343-352.

Tsakiris, M., Hesse, M., Boy, C., Haggard, P., & Fink, G.R. (2007). Neural correlates of body-ownership: A sensory network for bodily self-consciousness. *Cerebral Cortex*. 17, 2235-2244.

Tsakiris, M., Prabhu, G., & Haggard, P. (2006). Having a body versus moving your body: How agency structures body-ownership. *Consciousness and Cognition*. 15, 423–432.

Turkat, I.D., Guise, B.J., & Carter, K.M. (1983). The effects of vicarious experience on pain termination and work avoidance: A replication. *Behaviour Research and Therapy*. 21(5), 491–493.

Tversky, B., & Hard, B.M. (2009). Embodied and disembodied cognition: Spatial perspective taking. *Cognition*. 110, 124-129.

Valeriani, M., Betti, V., Le Pera, D., De Armas, L., Miliucci, R., Restuccia, D., . . . Aglioti, S.M. (2008). Seeing the pain of others while being in pain: A laser-evoked potentials study. *Neuroimage*. 40, 1419-1428.

Van Hemert, A.M., Hengeveld, M.W., Bolk, J.H., Rooijmans, H.G.M, & Vandenbroucke, J.P. (1993). Psychiatric disorders in relation to medical illness among patients of a general medical out-patient clinic. *Psychological Medicine*. 23,167-173.

Vignemont, F.D. (2007). Habeas Corpus: The sense of ownership of one's own body. *Mind and Language*. 22(4), 427-449.

Vogeley, K., Bussfeld, P., Newen, A., Herrmann, S., Happe, F., & Falkai, P. (2001). Mind reading: Neural mechanisms of Theory of Mind and self-perspective. *NeuroImage*. 14(1), 170-181.

Vogt, B.A., Berger, G.R., & Derbyshire, S.W.G. (2003). Structural and functional dichotomy of human midcingulate cortex. *European Journal of Neuroscience*. 18, 3134-3144.

Waddell, G. (1987). 1987 Volvo award in clinical sciences. A new clinical model for the treatment of low-back pain. *Spine*. 12(7), 632-644.

- Waddell, G., Feder, G., McIntosh, G., Lewis, M., & Hutchinson, A. (1996). *Low back pain evidence review*. London: Royal College of General Practitioners.
- Wall, P.D. (1999). *Pain: The science of suffering*. London: Wiedenfeld and Nicolson.
- Weinstein, A (1995) Visual ERP evidence for enhanced processing of threatening information in anxious university students. *Biological Psychiatry*, 37, 847-858
- Wessely, S., & White, P.D. (2004). There is only one Functional Somatic Syndrome. *British Journal of Psychiatry*. 185, 95-96.
- Whalley, M.G., Farmer, E., & Brewin, C.W. (2007). Pain flashbacks following the July 7th London bombings. *Pain*. 132, 332-336.
- Wheeler, M.E., Petersen, S.E., & Buckner, R.L. (2000). Memory's echo: Vivid remembering reactivates sensory-specific cortex. *Proceedings of the National Academy of Science*. 97, 11125-11129.
- Wicker, B., Keysers, C., Plailly, J., Royet, J.P., Gallese, V., & Rizzolatti, G. (2003). Both of us disgusted in my insula: The common neural basis of seeing and feeling disgust. *Neuron*. 40, 655-664.
- Wolfe, F., Smythe, H.A., Yunus, M.B., Bennett, R.M., Bombardier, C., Goldenberg, D.L., . . . Clark, P. (1990). The American College of Rheumatology 1990 Criteria for the

classification of Fibromyalgia. Report of the Multicenter Criteria Committee. *Arthritis and Rheumatism*. 33(2), 160-172.

Wolff, N., Darlington, A., Hunfeld, J., Verhulst, F., Jaddoe, V., Hofman, A., . . . Tiemeier, H. (2010). Determinants of somatic complaints in 18-month-old children: The Generation R Study. *Journal of Paediatric Psychology*. 35(3), 306-316.

Wood, G. C., Bentall, R. P., Gopfert, M., Dewey, M. E. & Edwards, R. H. (1994). The differential response of chronic fatigue, neurotic and muscular dystrophy patients to experimental psychological stress. *Psychological Medicine* 24, 357-364.

Wunsch, A., Philippot, P., & Plaghki, L. (2003). Affective associative learning modifies the sensory perception of nociceptive stimuli without participant's awareness. *Pain*. 102, 27-38.

Yen, C.P., Kung, S.S., Su, Y.F., Lin, W.C., Howng, S.L., & Kwan, A.L. (2005). Stereotactic bilateral anterior cingulotomy for intractable pain. *Journal of Clinical Neuroscience*. 12(8), 886-890.

Yeziarski, R.P., Gerhart, K.D., Schrock, B.J., & Willis, W.D. (1983). A further examination of effects of cortical stimulation on primate spinothalamic tract cells. *Journal of Neurophysiology*. 49(2), 424-441.

Zacks, J.M., & Michelon, P. (2005). Transformations of visuospatial images. *Behavioural and Cognitive Neuroscience Reviews*. 4(2), 96-118.

[The Appendices are not available in the digital version
of this thesis]