

**COLLOCATION AND PREPOSITION SENSE:
A PHRASEOLOGICAL APPROACH TO THE COGNITION OF
POLYSEMY**

by

YOSHIHITO KAMAKURA

**A thesis submitted to
the University of Birmingham
for the degree of
DOCTOR OF PHILOSOPHY**

**Department of English
School of English, Drama and American Studies
College of Arts and Law
The University of Birmingham
February 2011**

ABSTRACT

This study explores the relationship between the ‘sense’ of the prepositions *over*, *into* and *through* and the combined ‘form’ of their preceding and following nouns, using the hypothesis that the co-occurring nouns can predict different senses of the prepositions. It uses concepts drawn from both corpus linguistics and cognitive linguistics, in particular drawing on theories of phraseology formulated by Sinclair and others and on theories of preposition meaning formulated by Langacker and Taylor.

1,366 instances of the use of the prepositions from the ICE-GB corpus were examined. The results indicate a relationship between the senses of prepositions and their co-occurring nouns together with some features of their linguistic behaviour. *Over*, *into* and *through* have similar patterns when their trajector and landmark are combined. The thesis draws on statistical information regarding Human, Concrete object and Abstract object classifications to explore the distribution of sense of *over*. It uses equivalent information relating to *into* and *through* to reinforce and amend the semantic networks for these prepositions proposed by Lakoff and by Tyler and Evans.

DEDICATION

To Fusako and Kent

ACKNOWLEDGEMENTS

I came alone to the university and found a high-rise clock tower that psychologically overpowered me. I was fearful about earning a degree at a foreign country. My wife came to Birmingham three months afterwards and our life in pursuit of the PhD degree started.

With a deep sense of gratitude, I want to express my sincere thanks to my supervisors. Professor Susan Hunston has offered immense help and valuable suggestions. Every time we have met, for five years, I have enjoyed her cheerful supervision. Without her help, I could never have reached this stage. My sincere thanks are due to Dr. Jeannette Littlemore for offering clear advice, encouragement and guidance in the course of writing this thesis. I am also grateful to Dr. Eve Richards for offering clear advice about my academic writing any weekend when I asked for proofreading. I owe particular thanks to Ken and Liz Pheysey for their tremendous help and great generosity in treating my wife and me as part of their family. Finally, my greatest gratitude always goes to my dearest wife, Fusako. I would like to thank her for her constant care, especially for making a lunch box for me every day that I studied at the university. Without her loving support, I would never have completed my present work.

My son, Kent, was born in England in August last year. I arrived here on my own and then Fusako came. Now, three of us are going back to my home country, Japan, with the title of PhD.

TABLE OF CONTENTS

Chapter 1 INTRODUCTION	1
Chapter 2 LITERATURE REVIEW	7
2.1 Categorization	7
2.2 Prototype and semantic network.	12
2.2.1 Prototype	12
2.2.2 Semantic network	19
2.2.3 Trajector and landmark	23
2.3 Embodiment and image schema	28
2.4 Metonymy and metaphor	38
2.5 Phraseology	50
2.6 Lexical priming	53
2.7 Approaches of corpus linguistics to prepositions	58
2.8 Meaning and lexical representation	63
2.8.1 Lexical representation and semantic composition	64
2.8.2 LCCM Theory concerning polysemy	67
2.9 Summary of the chapter	69
Chapter 3 DATA AND METHODOLOGY	71
3.1 Corpus data	72
3.2 HCA classification.	74
3.2.1 Experiment on the HCA classification.	76
3.2.2 Metaphorical extension of the HCA combinations	80
3.3 Prototypicality of the senses of prepositions	84
3.3 Summary of the chapter	87
Chapter 4 PILOT STUDY: TR AND LM COMBINATIONS IN SEVEN PREPOSITIONS	89
4.1 Chi-square test of the distribution of HCA combinations	90
4.2 Cluster dendrogram and analysis of the clustering	94
4.3 Summary of the chapter	99
Chapter 5 THE MEANING COMPONENTS OF <i>OVER</i>	101
5.1 The polysemy and semantic network of <i>over</i>	101
5.2 The case studies of <i>over</i>	103

5.2.1 The central schema of <i>over</i> .	103
5.2.2. Motivations behind the semantic network	107
5.2.3. Sentential components of senses of <i>over</i>	109
5.3 Corpus research on the guiding senses of <i>over</i>	111
5.3.1 Overview of the distribution of senses	113
5.3.2 Sense and the sentential components in the corpus	115
5.3.3 Implications about the analysis of the over senses in the semantic network	157
5.4 TR and LM combination	164
5.4.1 Distribution of TR and LM combination	164
5.4.2 Overused and underused combinations of TR and LM	168
5.4.2.1 Overused CC combination	169
5.4.2.2 Overused AA combination	172
5.4.2.3 Underused CA and AC combination	175
5.4.3 Embodied and figurative senses with the TR of human being	177
5.5 Summary of the chapter	179
Chapter 6 ANALYSIS OF INTO	181
6.1 Distribution of HCA	183
6.2 Central and derived senses of <i>into</i>	187
6.2.1 Mental representation of the central sense of <i>into</i>	187
6.2.2 Trajector and landmark of <i>into</i>	191
6.2.3 Derived senses of <i>into</i>	193
6.3 HCA classification of <i>into</i>	198
6.3.1 CC combination and the central sense of <i>into</i>	198
6.3.2 HC and CH combination	203
6.3.3 HH combination	207
6.3.4 HA combination	210
6.3.5 AH, CA and AC combination	215
6.3.6 AA combination	217
6.4 Implications of the HCA combination analysis	221
6.5 Summary of the chapter	228
Chapter 7 ANALYSIS OF THROUGH	229
7.1 Distribution of HCA	230
7.2 Central and derived senses of <i>through</i>	236
7.2.1 Mental representation of the central sense of <i>through</i>	236
7.2.2 Derived senses of <i>through</i>	239

7.3 HCA classification of <i>through</i>	242
7.3.1 CC and HC combinations and the central sense of <i>through</i>	243
7.3.2 CH and HH combinations	255
7.3.3 HA combination	258
7.3.4 AH, CA and AC combinations	264
7.3.5 AA combination	266
7.4 Implications of the HCA combination analysis	268
7.5 Summary of the chapter	274
Chapter 8 DISCUSSION AND CONCLUSION	275
8.1 HCA combinations and the senses of the preposition	276
8.2 The HCA combinations and semantic network	286
8.3 Metaphor in the semantic network	294
8.4 Applications of the results and limitations	301
8.5 Conclusion and future work	307
APPENDICES	310
REFERENCES	416

APPENDICES

Appendix 1: Enquiries and questionnaire concerning classification (Chapter 3)	310
Human (animate), concrete object and abstract object classification enquiries	311
Questionnaire of senses of preposition	313
Appendix 2: Statistics of the Pilot Study (Chapter 4)	314
3x3 distribution of HCA combination of seven prepositions	315
Appendix 3: HCA classification and the senses of <i>over</i> of the ICE GB data (Chapter 5)	316
Concordance lines of verb + <i>over</i>	317
Concordance lines of verb + noun phrase + <i>over</i>	326
Proto-scene (1)	329
On-the-other-side-of (2A)	330
Above-and-beyond (Excess I) (2B) and Completion (2C)	334
Transfer (2D)	335
Temporal (2E)	336
Covering (3)	339
Examining (4)	341
Focus-of-attention (4A)	342
More (5A) and Over-and-above (Excess II) (5.A.1)	344
Control (5B) and Preference (5C)	345
Reflexive (6) and Repetition (6A)	347
Appendix 4: HCA classification and the senses of <i>into</i> of the ICE GB data (Chapter 6)	348
Concordance lines of verb + <i>into</i>	349
Concordance lines of verb + noun phrase + <i>into</i>	364
CC combination	367
HC combination	371
HH combination	375
HA combination	376
CA combination	382
AC combination	383
AA combination	384

Appendix 5: HCA classification and the senses of <i>through</i> of the ICE GB data (Chapter 7)	390
Concordance lines of verb + <i>through</i>	391
Concordance lines of verb + noun phrase + <i>through</i>	400
CC combination	402
HC combination	404
CH combination	406
HH combination	407
HA combination	408
AH combination	411
CA combination	412
AC combination	413
AA combination	414

LIST OF FIGURES

Figure 2.1	Semantic category of BIRD	9
Figure 2.2	Family resemblance	10
Figure 2.3	Mental representations of <i>in, on, at</i>	13
Figure 2.4	Mental representations of ' <i>Jump over the box</i> ' and ' <i>The plane flew over the town</i> '	18
Figure 2.5	Idealised semantic network with radial category	20
Figure 2.6	Semantic network of <i>over</i> by Lakoff	21
Figure 2.7	Semantic network of <i>over</i> by Tyler and Evans	23
Figure 2.8	Rubin's vase	24
Figure 2.9	Trajector and landmark	25
Figure 2.10	Trajector and landmark of <i>through</i>	27
Figure 2.11	Pear in the bowl	31
Figure 2.12	Distribution patterns of the dependence sense of <i>on</i>	35
Figure 2.13	Distribution patterns of the locative and dependence senses of <i>on</i>	36
Figure 2.14	Mapping from the source domain to the target domain	40
Figure 2.15	The moving time model	47
Figure 2.16	The moving ego model	48
Figure 2.17	The semantic network for <i>over</i>	49
Figure 2.18	Semantic associations of collocation with preposition	63
Figure 2.19	Architecture of LCCM Theory	65
Figure 4.1	Dendrogram of the residuals of HCA combinations	94
Figure 4.2	HCA distribution patterns in the trajector-centred order	97
Figure 4.3	HCA distribution patterns in the landmark-centred order	98
Figure 5.1	The central schema of <i>over</i> , adapted from Lakoff	104
Figure 5.2	The central schema of <i>over</i> , adapted from Dewell	105
Figure 5.3	The proto scene of <i>over</i>	106
Figure 5.4	Configuration of an on-line meaning as in <i>The hummingbird hovered over the flower</i>	109
Figure 5.5	Component, relational, and integrative schema	110
Figure 5.6	The semantic network for <i>over</i>	112
Figure 5.7	The mental representation of (15) and (16)	118
Figure 5.8	The mental representation of (17) and (18)	119
Figure 5.9	<i>The cat jumped over the wall</i>	122
Figure 5.10	Geometric transition of covering sense, partly adapted from Lakoff	135
Figure 5.11	The mental representation of more sense	143

Figure 5.12	Clause pattern of the more sense of <i>over</i> with quantity verbs	145
Figure 5.13	Clause pattern of the more sense of <i>over</i> with be and over	146
Figure 5.14	The mental representation of the excess senses	147
Figure 5.15	The mental representation of the reflexive sense	153
Figure 5.16	The repetition sense	155
Figure 5.17	Radial network of the <i>over</i> senses	158
Figure 5.18	Degree of the relevance to the central schemata	159
Figure 5.19	Generation of the meaning of <i>The cat jumped over the wall</i>	164
Figure 6.1	Distribution pattern of Table 6.2	185
Figure 6.2	Distribution pattern of Table 6.3	186
Figure 6.3	Diagrams of prepositions	188
Figure 6.4	Diagram of <i>into</i>	188
Figure 6.5	Proto-scene for <i>into</i>	189
Figure 6.6	Foregrounding in path movement	191
Figure 6.7	Partially bounded LM of <i>into</i>	192
Figure 6.8	Clause pattern of the change into parts sense in CC combination	201
Figure 6.9	Semantic network of CC combinations	203
Figure 6.10	Semantic network of HC combination	207
Figure 6.11	Semantic network of HH combination	208
Figure 6.12	Semantic network of HA combination	211
Figure 6.13	Clause pattern of the involvement sense in HA combination	213
Figure 6.14	Clause pattern of the starting an action sense in HA combination	214
Figure 6.15	Clause pattern of the concerning/about sense in HA combination	215
Figure 6.16	Semantic network of AA combination	218
Figure 6.17	Clause pattern of the combination of starting a state containing <i>COME into</i> in AA	219
Figure 6.18	Semantic network of <i>into</i>	224
Figure 6.19	Frequency-based semantic network <i>into</i>	225
Figure 6.20	Domains of the HCA combinations	226
Figure 6.21	Radial category of the CC combination	227
Figure 6.22	Radial category of the HA combination	227
Figure 7.1	Phrase pattern of adverbial <i>through</i>	232
Figure 7.2	Mental representation of the phrase containing <i>through to</i> noun phrase	233
Figure 7.3	Distribution pattern of Table 7.3	235
Figure 7.4	Distribution pattern of Table 7.4	236
Figure 7.5	Mental representation of <i>through</i>	237
Figure 7.6	Referential points of <i>through</i> and <i>over</i>	238

Figure 7.7	Spatial configuration of Example (7)	239
Figure 7.8	Radial network of extensions of <i>through</i>	241
Figure 7.9	Semantic network of CC combination	245
Figure 7.10	Semantic network of HC combination	245
Figure 7.11	Clause pattern of the traversal sense in CC combination	249
Figure 7.12	Clause pattern of the traversal sense in HC combination	249
Figure 7.13	Clause pattern of the on-the-other-side-of, completion sense of <i>through</i>	251
Figure 7.14	Semantic network of the HH combination	256
Figure 7.15	Clause pattern of the ‘make someone do’ sense in HH combination	257
Figure 7.16	Semantic network of the HA combination	258
Figure 7.17	Semantic network of AH combination	265
Figure 7.18	Semantic network of AA combination	267
Figure 7.19	Semantic network of <i>through</i>	270
Figure 7.20	Frequency-based semantic network of <i>through</i>	271
Figure 7.21	Domains of the HCA combinations	272
Figure 7.22	Radial category of the CC and HC combinations	273
Figure 7.23	Radial category of the HA and AA combinations	273
Figure 8.1	Standard residuals of the HCA combinations of <i>over</i> , <i>into</i> and <i>through</i>	278
Figure 8.2	Generation of the meaning of <i>The cat jumped over the wall</i>	284
Figure 8.3	The semantic network for <i>over</i>	288
Figure 8.4	Domains of the HCA combinations of <i>into</i>	292
Figure 8.5	Radial category of the HA combination of <i>into</i>	293
Figure 8.6	Domains of the HCA combinations of <i>through</i>	297

LIST OF TABLES

Table 2.1	Features of primary object and secondary object	26
Table 2.2	List of image schemata	31
Table 2.3	Ratings of the image schemas of <i>on</i> and <i>to stand</i>	37
Table 2.4	The temporal sense of prepositions	45
Table 2.5	Definitions of collocation, colligation, semantic preference and semantic prosody	52
Table 2.6	Lexical description of <i>naked eye</i>	52
Table 2.7	The contrasting collocations, semantic associations, pragmatic associations, colligations and textual colligations of the two uses of <i>consequence</i>	57
Table 3.1	Instances of V prep and V O prep retrieval from the ICE GB	73
Table 3.2	HCA combinations of the TR and the LM	75
Table 3.3	Experiment of the HCA classification	77
Table 3.4	CC combination as the central sense	81
Table 3.5	HC and CH combinations as peripheral senses	82
Table 3.6	HH combination as a peripheral sense	82
Table 3.7	Combinations containing an abstract object as peripheral senses	83
Table 3.8	HCA combinations in the order of the central to peripheral senses	84
Table 3.9	Questionnaire on the degree of concreteness of <i>into</i>	86
Table 4.1	Incidence of VB + preposition in the Bank of English and the ranking of frequent prepositions	89
Table 4.2	Overuse and underuse of subject and object combinations	91
Table 4.3	Residuals and significant overuses and underuses	95
Table 5.1	Distribution of senses of <i>over</i> in the ICE GB	114
Table 5.2	Verbs and sentence structures in the sense of proto scene	120
Table 5.3	Verbs and sentence structures in the sense of on-the-other-side-of	125
Table 5.4	Verbs and sentence structures in the above-and-beyond sense	127
Table 5.5	Verbs and sentence structures in the completion sense	129
Table 5.6	MI and t-score of co-occurring verbs and nouns with temporal <i>over</i>	132
Table 5.7	Covering senses and the co-occurring verbs	136
Table 5.8	TR and LM in distributive location covering senses	137
Table 5.9	TR and LM in multiplex path covering senses	137
Table 5.10	TR and LM in concealing covering	138
Table 5.11	TR and LM in examining sense	140
Table 5.12	TR and LM in the more sense	143
Table 5.13	TR and LM of the over-and-above sense (Excess II)	148

Table 5.14	TR and LM of the reflexive sense	154
Table 5.15	TR and LM of the repetition sense	155
Table 5.16	The senses of <i>over</i> in the order of high proportion of without LM	166
Table 5.17	HCA combination of TR and LM	167
Table 5.18	TR and LM combination with the distribution of the <i>over</i> senses	169
Table 5.19	Units of meaning of the temporal sense <i>over</i>	173
Table 5.20	Units of meaning of deterioration and aggravation <i>over</i>	174
Table 5.21	Units of meaning of the focus-of-attention <i>over</i>	175
Table 5.22	Passives of the underused CA combination	176
Table 6.1	HCA distribution of the TR and LM with <i>into</i>	183
Table 6.2	Standard residuals of HCA combinations containing <i>into</i> in the pilot study and ICE GB	184
Table 6.3	Residuals of <i>over</i> and <i>into</i> and the significance of overuse and underuse	186
Table 6.4	Senses of <i>into</i> by Lindkvist	194
Table 6.5	The meaning extensions of prepositions	196
Table 6.6	Senses of V into n and meaning extensions of prepositions	197
Table 6.7	TR and LM in change into parts sense	201
Table 6.8	Distribution of the senses in CC combination	202
Table 6.9	TR, LM and verbs in the orientation sense of HC combination	204
Table 6.10	TR, LM and verbs in the change into parts sense of HH combination	209
Table 6.11	TR, LM and verbs in the encounter sense of HH combination	210
Table 6.12	TR, LM and verbs in the time sense of HA combination	212
Table 6.13	Distribution of the HCA combinations and the senses of <i>into</i>	222
Table 7.1	Adverbial use of <i>through</i> and <i>over</i> in the ICE GB	230
Table 7.2	HCA distribution of the TR and LM of <i>through</i>	234
Table 7.3	Standard residuals of HCA combinations containing <i>through</i> in the pilot study and ICE GB	234
Table 7.4	Residuals of <i>over</i> , <i>into</i> and <i>through</i> and the significance of overuse and underuse	236
Table 7.5	Senses of <i>through</i> by Lindkvist	240
Table 7.6	The senses of <i>through</i> suggested by Tyler and Evans	242
Table 7.7	Distribution of the HCA combination and the senses of <i>through</i>	243
Table 7.8	Sense distribution of <i>through</i> in the CC and HC combinations	244
Table 7.9	Spread covering senses of <i>through</i> phrases in the CC combination	252
Table 7.10	Spread covering senses of <i>through</i> in the combinations except for the CC	252
Table 7.11	TR and LM of the ‘by means of’ sense in CC combination	255
Table 7.12	TR and LM of the ‘by means of’ sense in HC combination	255

Table 7.13 TR, LM and verbs of the ‘make someone do’ sense in HH combination	257
Table 7.14 Verbs and LMs with <i>through</i> , <i>over</i> and <i>into</i> in the temporal sense	259
Table 7.15 TR, LM and verbs of the experience sense in HA combination	260
Table 7.16 Distribution of the HCA combinations in the examining sense	262
Table 7.17 <i>Go</i> + <i>over/into/through</i> in the examining sense	262
Table 7.18 TR, LM and verb of the examining sense in HA combination	263
Table 7.19 TR, LM and verb of the make someone do sense in AH combination	265
Table 7.20 TR, LM and verb of the reason/because of sense in the AA and HA combinations	268
Table 7.21 Units of meaning of the ‘reason/because of’ sense of <i>through</i>	268
Table 7.22 Distribution of the HCA combinations and the senses of <i>through</i>	270
Table 8.1 Distribution of the HCA combinations and the senses of <i>into</i>	282

LIST OF ABBREVIATIONS

TR trajector

LM landmark

HCA human, concrete objects and abstract objects

HH human trajector and human landmark

HC human trajector and concrete object landmark

HA human trajector and abstract object landmark

CH concrete object trajector and human landmark

CC concrete object trajector and concrete object landmark

CA concrete object trajector and abstract object landmark

AH abstract object trajector and human landmark

AC abstract object trajector and concrete object landmark

AA abstract object trajector and abstract object landmark

1. INTRODUCTION

Great literature is simply language charged with meaning to the utmost possible degree. (Pound, 1931)

The quotation above, from the American poet, Ezra Pound, asserts that a great work of literature gives meaning to language and uses language functions as a vehicle to convey all possible nuances of meaning. From my viewpoint as a linguist, the quotation also seems to suggest that we think that ‘language’ and ‘meaning’ are distinct and that language is a medium to carry the meaning which we want to express. I always wonder how we associate language with meaning and specify one particular meaning without getting it confused with another similar one. Obviously, language must function to specify meaning. However, where does meaning come from and what precisely carries it? How is it transmitted? These questions lead to one of the key questions of linguistics, the relationship between ‘form’ and ‘meaning’. The central aims of this thesis are to find where meaning resides in language and to discuss the extent to which language contributes to establishing meaning. I would like to adopt the methodology of focusing on the nouns, the verbs and the sentence structure which co-occur with prepositions in order to analyse how far the collocates predict the senses¹ of these prepositions.

1.1 Meaning and language

The relationship between meaning and language has been discussed in various areas of linguistics. Corpus linguists, for example, argue that meaning is specified by phrases and pattern (e.g., Sinclair, 1991a; Hunston and Francis, 2000). In other words, a particular

¹ I use the term ‘sense’ signifying that meaning is generally agreed and defined in dictionaries, whereas ‘meaning’ indicates a precise and flexible description of relationships which vary according to the setting.

meaning co-occurs with specific phrases and patterns. Such a 'phraseological' approach is likely to answer my earlier question as to how a 'form' as represented in language determines 'meaning'. It is, however, the case that form and meaning tend not to have a one-to-one relationship, as there exist a number of polysemous words and phrases, such as phrasal verbs, which have more than one sense (e.g., *LOOK through a key hole* and *LOOK through documents*). This seems to suggest that even the phraseological approach is unlikely to specify meaning due to excluding the involvement of nouns for meaning construction. Moreover, it is likely that cognitive linguists claim that the lexical representation of phrase can satisfactorily represent meaning and disregards the detailed features of entities involved in the setting where meaning is conveyed. As it is suggested that the range of a phrase can be indefinite (Sinclair, 1991a), the other elements of phrase, nouns in this case, should be examined to discover the formation of meaning. Hence, this study explores the collocation of the nouns co-occurring with prepositions, which have hardly been highlighted to date, and classifies the nature of the nouns in order to see differences in meaning.

Cognitive linguists argue that our knowledge of the world helps us to interpret intricate meaning (Evans, 2009; Langacker, 1987; Tyler and Evans, 2003a), and language serves to indicate part of the meaning. More specifically, language can trigger the interpretation of meaning, but it cannot specify the meaning without knowledge of the world. Our knowledge of the world is represented by nouns which our conceptualisations are named for. Investigating nouns can be justified, not only by extending the phraseological approach to nouns, but also by seeing the involvement of our world knowledge in meaning construction. In other words, investigating nouns preceding and following a preposition is likely to suggest how meaning differs in the nature of nouns which bear our world knowledge, and to demonstrate the way in which nouns phraseologically relate to the co-occurring preposition. As a result, this approach can empirically show the relationship between lexical representation

generated by collocation and meaning construction dependent on our world knowledge.

Thus, this study focuses on how far language specifies meaning and contributes to interpretation: when more than one sense is available, language determines one particular sense of a polysemous preposition in each case.

1.2 Polysemy in prepositions

Cognitive linguists have investigated polysemy in prepositions by discovering the factors of multi-senses, such as verticality and trajectory, which are thought to lie behind the meaning (Bennett, 1975; Dewell, 1994; Kreitzer, 1997; Lakoff, 1987; Lindkvist, 1976). The aims are to describe the semantic memory of language users, which retain different senses, by disregarding the context of prepositional settings (Evans, 2009). In other words, the entities involved in prepositional configuration have been little studied in the study of polysemy in cognitive linguistics. This study can shed light on ‘contexts’, which are represented by nouns, verbs and other words, in order to describe polysemy in prepositions on the hypothesis that a particular ‘form’ relates to a particular ‘meaning’ of prepositions.

In addition, the challenges of those researchers failed to describe the nuances of meaning which varied according to the different entities involved in the configuration. As Tyler and Evans suggest (2003a), the ‘locating above’ sense of *over* does differ in the two sentences *The cat jumped over the wall* and *The hummingbird hovered over the flower*. The meaning in the real world, which varies according to settings, can be ‘context-dependent’ (Evans, 2009: 11). The differences in the meanings of these examples are probably due to the nature of such constituents of the context as *cat* and *wall*, *hummingbird* and *flower*. The analysis of the noun collocates is expected to indicate the nuances of sense, which conventional approaches were inclined to encompass into an individual sense.

LCCM Theory, suggested by Evans (2009), holds that polysemous prepositions can

have more than one sense associated with a single phonological form, since language functions to prompt access to lexical concepts which closely relate to different senses. In the classic approach to the polysemy of prepositions, the senses were assumed to be generally fixed and prepositions to have ‘context-independent meaning’. Drawing on LCCM Theory, I hypothesise that the two principal constituents represented by a noun phrase may function to infer the context of the prepositional meaning. This hypothesis is a theory of cognitive linguistics which holds that our cognition of spatial relationships is composed of two entities involved (Langacker, 1987), and the theory offers a rationale for collocation of the nouns preceding and following the preposition. In this study, a large amount of analysis of the usage of prepositions is carried out in order to see whether the sense is determined by the linguistic representation of noun collocates and how far language contributes to context-dependent meaning construction.

1.3 Research questions

In the present research, 1,366 instances of prepositional phrases extracted from corpus data were analysed and the nouns co-occurring before and after the prepositions *over*, *into* and *through* were categorised into ‘animate’, ‘concrete object’ or ‘abstract entity’ applications. These categories are hypothesised to reflect our construal to the real world and the combination of the nouns preceding and following the preposition. This new procedure fills a gap in the previous research. To my knowledge, little research into the polysemy of prepositions has been conducted by analysing a corpus, a large quantity of real language data, which has been compiled from various media. I would argue that the senses of prepositions are likely to correspond to their linguistic environment, which is created by the co-occurring phrases. This study focuses on the relationship of prepositional senses with the preceding and following nouns, in what I call ‘preposition-centred phrases’.

The novelty of this approach lies in providing a rationale for analysing noun collocates by adopting the theory of the two principal entities in spatial configuration, the ‘trajector’ and the ‘landmark’ (Langacker, 1987: 231). This challenge bridges the gap between corpus linguistics and cognitive linguistics. In the theory of corpus linguistics, specifically in phraseology, collocation and pattern represent meaning, whereas cognitive linguists argue that the entities indicated by a noun are closely involved in the spatial configuration of prepositions. This hypothesis of the collocation of prepositional-centred phrases agrees with the latest suggestions concerning the relationship between collocation and meaning offered by cognitive linguists (Evans, 2009; Goldberg, 1995; Taylor, 2003). My approach is expected to explore how far the collocation and pattern of a preposition determines one sense of a polysemous preposition. The research questions of this study are as follows:

1. Is there a relationship between the senses of prepositions and their co-occurring nouns?
2. If there is indeed a relationship of this kind, how far can the co-occurring nouns predict the sense of the preposition? Can the classification of the nouns, which, I hypothesise, is one type of reflection of our construal, contribute to describing the polysemous senses of prepositions?
3. Can the comprehensive language data of a corpus, which is not based on researchers’ intuition, shed light on different aspects of the description of prepositional senses?

This thesis is structured as follows. Chapter 1 introduces the aims and the research questions of the study. Chapter 2 provides a review of the research done so far which relates to the senses of prepositions in cognitive linguistics and corpus linguistics. Chapter 3 describes the data and the methodology which were employed in this study. Before turning to the main analyses, Chapter 4 introduces a pilot study on the relationship between seven

prepositions and their noun collocates and explains the reasons for choosing the prepositions *over*, *into* and *through* for the following analyses.

Chapters 5 to 7 present the main analyses of the relationships between the sense of the prepositions and their preceding and following nouns. Chapter 5 introduces the analysis of *over* and revisits the preceding studies concerning the senses of *over* in order to see how far the combination of the trajector and the landmark is compatible with the polysemous senses of *over*. The chapter also presents a statistical account of the TR and LM combinations and the senses of *over*. Based on the results of the analysis in Chapter 5, an original set of the senses of *into* and their semantic network are provided in Chapter 6. By examining the corpus, the combinations of the noun collocates are examined to describe the senses of *into*. Chapter 7 extends the study to the senses of *through*. In the same manner as the account of *into*, the senses of *through* are described by investigating the corpus and a semantic network is established on the basis of the HCA combinations. The topic of the final chapter, Chapter 8, is the discussion of this research to assess how far HCA combinations are applicable to the description of the senses of prepositions. This chapter also contains the applications of the HCA combinations and some concluding remarks.

2. LITERATURE REVIEW

This literature review aims to provide theoretical accounts of prepositions by examining the research in cognitive linguistics and corpus linguistics. These two types of linguistics seem to differ in the rationale underlying their theories of meaning: The former holds that the physiological experience of language users involves the conceptualisation of meaning; the latter attempts to describe meaning by a comprehensive analysis of the collocations and patterns in language. In other words, in cognitive linguistics, determining meaning is seen as a largely human activity, whereas in corpus linguistics, language *per se* is considered to account for the transmission of meaning. In describing the meaning of prepositions, I would like to bridge this gap between the different theories of linguistics. This chapter introduces the main hypotheses of cognitive linguistics relating to the analysis of prepositions and provides accounts of the theories of corpus linguistics. It then summarises an account of the connections between cognitive linguistics and corpus linguistics, in an attempt to describe the senses of prepositions.

2.1 Categorization

After the advent of cognitive semantics, based largely on the studies of philosophy (e.g. Wittgenstein, 1953) and psychology (e.g. Rosch, 1973), the descriptions of the senses of words changed dramatically. Until then, the primary purpose of analysing the senses of a word was to discover its common attributes. It was believed that there were attributes, represented by the semantic units and components as introduced above, which were shared by the various senses of one lexical item. In the case of *into*, it is likely that ‘penetration’ is a necessary and sufficient condition of all the senses conveyed by the preposition. Yet it does not seem to be the case that the ‘metamorphosis’ sense of *into* encompasses the concept of penetration among its components. According to the cognitive linguistic approach, the key to

the description of a word is its categorization, not the attributes shared by all its senses. Hence, the traditional approach suggested by Aristotelians that categorization lies in exclusive attributes is unlikely to apply to such a flexible category as *into*.

The classical approach of basing category on a set of necessary and sufficient conditions can be also refuted by a word such as ‘game’ (*‘spiel’* in German, Wittgenstein, 1953). What is the common attribute of ‘game’? It may be winning or losing, but children and sometimes others play a game for fun, not always in order to win it. It may involve luck; however, chess players are expected to have more skill than luck. Games are expected to be amusing, but some games put players under intolerable pressure. As a result, Wittgenstein concludes that the senses of a word are categorized by the way in which a particular feature within the same category is shared by some members, but at the same time other members can belong to the category by sharing a different feature. The finding that the category of game is composed of several features counters the traditional theory of categorization in which conditions are common in all the members of the category. Such flexible categorization is defined as ‘family resemblance’, which derives from the partial similarity common to all the members of a family, who are nevertheless recognised as a family. Take BIRD¹ for instance, as shown in Figure 2.1 below: ‘birds’ is the name generally given to small vertebrates which can fly. However, there are birds which cannot fly, such as >ostriches< and >penguins<². Some contend that flying in the sky is a common attribute of birds, or that birds have small yellow beaks. But >ducks<, >geese< and >swans< spend plenty of time in ponds and >storks<, >ostriches< and >flamingos< possess relatively large beaks and long necks. Despite these differences, we recognise all of them as birds, since the family resemblances shared by some of the members, such as ‘not flying’, ‘living in water’ and ‘large beaks and long necks’, help

¹ In this chapter, cognitive categories, concepts, cognitive and cultural models are shown in small upper-case.

² Members of categories are represented by arrows and small lower-case letters.

us to categorize them. Hence, as illustrated in Figure 2.2 below, different attributes, which are not necessarily shared by all members (A, B, C, D, E and F in the figure), contribute to establishing a category and are shared by some of the members (by A and B, B and C, and B and D, but not by F). Moreover, the fringe members which do not directly link with other members (A, C and E in the middle diagram in Figure 2.2) associate with others via the shared members (B and D). Such extension from a shared member to peripheral ones is dubbed a ‘radial category’ (Lakoff, 1987: 91), which can be observed in the category of BIRD in that >duck< and >stork< serve as the centre of radial extension (Figure 2.1).

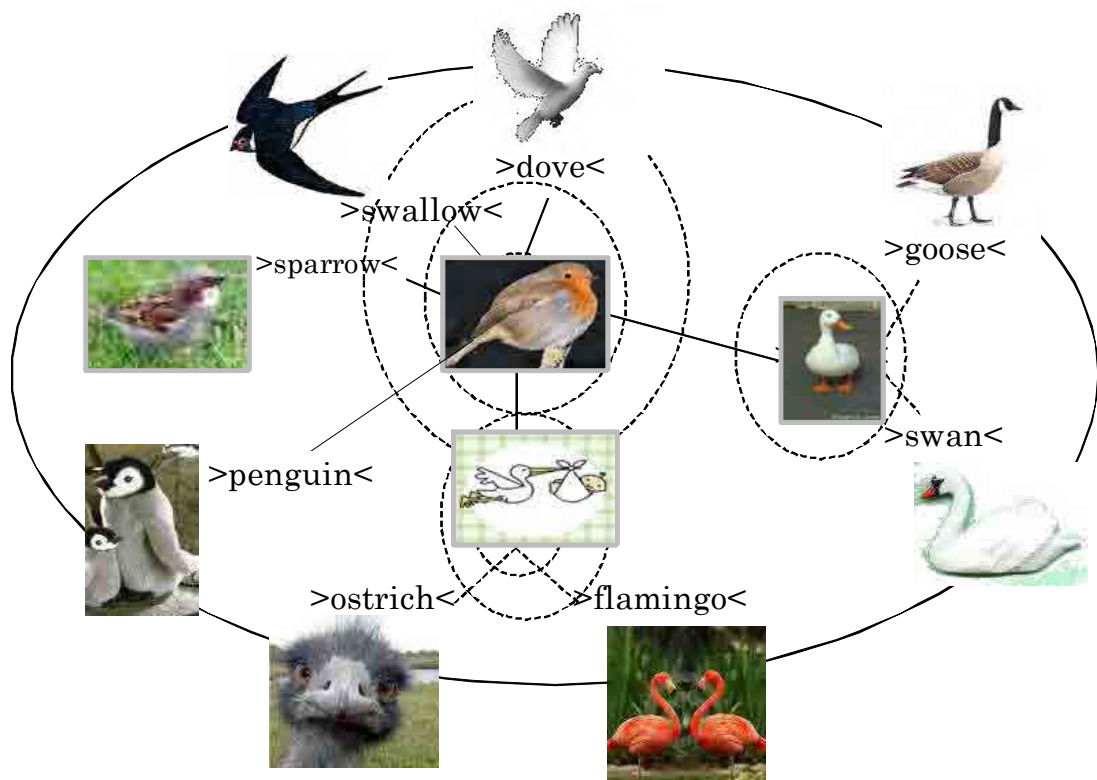

Figure 2.1 Semantic category of BIRD (adapted from Ungerer and Schmid, 2006: 30)

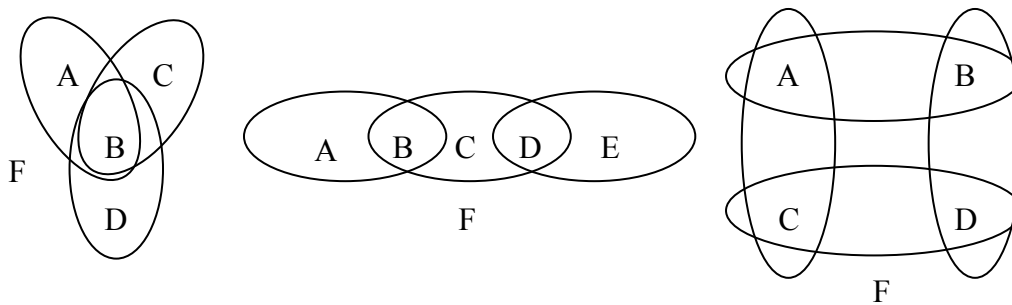

Figure 2.2 Family resemblance (Matsumoto, 2003: 29)

Wittgenstein’s categorization is necessarily complemented by the ‘prototype’ theory proposed by Rosch (1973), largely because his categorization cannot explain why, in a category, some examples are better than others (Lakoff, 1987; Taylor, 2003). For instance, as far as *into* is concerned, the physical penetration sense is more likely to be typical than the ‘metamorphosis’ sense – this asymmetry in members is defined as the ‘basic level category’ and is discussed in detail in the next section. Rosch (1973) examines how speakers of Dani could learn arbitrary invented words for colours, resulting in the names of ‘focal colours’, which are the basic colours general in many languages (Berlin and Kay, 1969) and are learnt more easily. This implies that good examples exist in the category of colours. The finding suggests that the prominence of focal colours originates from kinaesthetic, embodied experiences due to neurophysiological factors (Kay and McDaniel, 1978).

In view of these results, Lakoff (1987) and Taylor (2003) go on to say that categorization lies in ‘prototypicality’, which is discussed in detail in the next section (2.2), and ‘embodiment’ (likewise, in section 2.3), in an attempt to rebut the classic theory which holds that the shared features of members are key to establishing a category. Again, as regards BIRD in Figure 2.1, the category is hypothesised to have a central member, >robin<, and peripheral members, the other types of bird. And it is argued that we perceive the asymmetry between the members of the category owing to our experiences. If we allow that the prototype

can vary according to where we live and see examples of it, most of us would consider that the robin is probably the most typically recalled bird, largely because we see it more often than the others. However, unlike the birds which objectively exist, some members of preposition sense-categories cannot be observed or physically experienced. Although the traversal sense of *through*, for example, *a ball goes through legs*, can be seen and physically experienced, a metaphorical sense of the preposition is unlikely to see or touch the traversing movement, e.g., *He's just going through a divorce* <S1A-076 #042>. It can be thus suggested that there may exist a network of the senses of the preposition composed of typical and atypical members in the categorization of language, and it is argued that such categorization is ubiquitous in a number of features of language, such as morphology, syntax, grammar and even phonology (Taylor, 2003). Given that prototype theory allows a flexible category by ruling out the classic approach which supports necessary and sufficient conditions, the category of prepositions may be fuzzily organised by human perceptions about the locative sense, which is prototypical, and the metaphorical senses.

The research on prepositions in cognitive linguistics has explored the notion of embodiment encoded in prepositions, studying world languages and child language development. Spatial relations can be bodily experienced by seeing and touching them. Regarding world languages, the embodiment in spatial expressions was examined not only in European languages, such as Dutch (Cuykens, 1993), French (Hottenworth, 1993), German, (Carroll, 1997) and Italian (Taylor, 1988), but also in African (Heine, 1997) and Asian ones, such as Chinese (Yu, 1999) and Japanese (Hawkins, 1993, Kita, 2006). Similarly, the acquisition of spatial concepts and expressions with regard to child language was examined (Mandler, 1992; Bowerman, 1996; Clark, 1973; Landau, 1996; Freeman *et al.*, 1980), while some researchers investigated both aspects as the early stages of acquisition of spatial prepositions in non-English languages, such as Korean (Choi and Bowerman, 1991) and

Polish (Rohlfing, 2001). These studies aim at discovering universal and distinctive features of the various languages, as well as those in children's development of spatial concepts.

As we have seen, more theoretical approaches have been taken to prepositions, instead of an empirical examination of language data. I intend to analyse the instances of such prepositions as *over*, *into* and *through* on the basis of theories formulated in cognitive linguistics, which is discussed in the following sections, and in corpus linguistics, which theoretically depends on empirical language data. It should be noted that the category of prepositions is composed of physical and non-physical senses, and therefore its category is hypothesised to have a radial extension from a locative sense at the centre to metaphorical senses on the periphery.

2.2 Prototype and semantic network

2.2.1 Prototype

Unlike the classic approach to categorization, this research hypothesises that the members of a category consist of one central and several peripheral members. How can the central member be specified? It is argued that a prototype represents a 'good example' in the category (Lakoff, 1987; Taylor, 2003; Unger and Schmid, 2006) and it is a simple concept without detailed information which reflects the mental representation of language users. Rosch (1975) investigated the 'goodness-of-example' (Taylor, 2003: 46; Taylor, 2008: 41) of FURNITURE by asking 200 American college students to judge which member of this category was better than the others³. >Chair< appeared to be a better example in FURNITURE than >table< and >bed<. 'Prototype effects' give rise to such asymmetrical positions in members of a category (Taylor, 2003). It follows that better examples do exist in categories and each category is structured with the better example at its centre.

³ Rosch (1975) investigated the goodness-of-example of FURNITURE as well as those of FRUIT, VEHICLE, WEAPON, VEGETABLE, TOOL, BIRD, SPORT, TOY and CLOTHING.

The locative sense is highly likely to be prototypical in terms of prepositions, since a number of linguists provide accounts with a mental representation of the spatial relationship illustrated by diagrams, as in Figure 2.3 below, and they are often applied to explain the metaphorical senses too (Dirven, 1989; Lindstromberg, 1998; Quirk *et al.* 1985). A spatial configuration is considered to be the basic sense of a preposition and the physical relationship can stretch to accommodate the explanations of the metaphorical senses expressed by the same preposition. Consequently, the locative sense is conceptualised as the most typically recalled sense of prepositions, and the spatial relationship of entities involved, which can be represented by a diagram, maximises the differences in the attributes of prepositions, namely, containment in *in*, support in *on* and contiguity in *at* (Herskovits, 1988: 272). In other words, the locative sense of prepositions is prototypical in that it effectively highlights the prototypicality and the features which distinguish this one preposition from all the others.

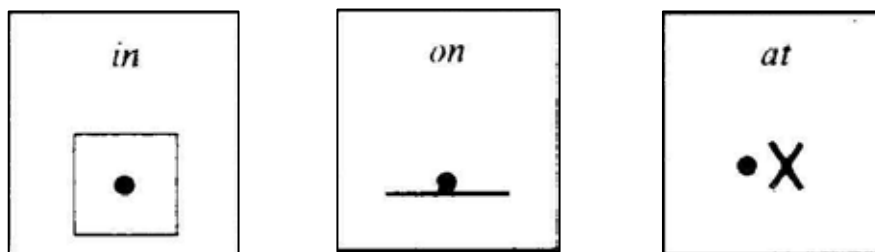

Figure 2.3 Mental representations of *IN*, *ON*, *AT* (Quirk *et al.*, 1985: 674)

Now let us turn to the hypotheses on the subject of where prototype emerges and the approaches to identifying prototype. Geeraerts (2007: 168) points out the four hypotheses which concern prototype:

- physiological
- referential
- statistical

- psychological

The physiological hypothesis is exemplified by the experiments conducted by Berlin and Kay (1969) and Rosch (1973), which were introduced in the previous section (see p.11). The results suggest a connection between physiological salience in colours and the establishment of the mental lexicon. However, this hypothesis is unlikely to apply to examination of the prototype of prepositions. This is because there is no physiological system here, in contrast to sight for the light frequencies of colours, to perceive the differences of prepositional senses, which vary from locative to metaphorical.

The referential hypothesis concerns the attributes shared by the members of category. This hypothesis states that the prototype shares a maximum number of attributes with the non-prototypical members of category. Preposition *through* is assumed to have an attribute of ‘traversal’, e.g., ...*with light coming through a pane of glass* <S1B-015 #097>. The attribute of physically traversing an object seems less likely to be shared by the ‘by means of’ sense, as in *The winch...operated through a crown block* <W2A-031 #091>. Presumably, metaphor and metonymy, which are examined in Section 2.4, may be involved in the semantic extension of the traversal attribute. Establishing a semantic network of prepositions may possibly contribute to comparing different senses of a preposition and discovering the sharing of attributes between the members of a category. Moreover, ‘cue validity’ (Lakoff, 1978: 52-54; Rosch, 1978; Taylor, 2008: 45), which represents the degree of probability of a particular attribute occurring in a member of the category, closely relates to prototypicality, because a prototypical member shares a maximum number of attributes (Taylor, 2008). For example, flying is a strong cue validity to belonging to the BIRD category, whereas having a long neck is unlikely to predict a prototype of birds.

The statistical hypothesis states that the prototype is the most frequently experienced member in the category and that its frequency in relation to the other members determines its

prototypicality. Although this proposition is controversial, I would argue that frequency may relate to prototypicality, but not in a straightforward way (Bybee and Hopper, 2001; Geeraerts, 2007; Gibbs, 2006; Goldberg, 2006; Taylor, 2008). Given that high frequency does not necessarily determine which is the prototype, high frequency “may well be a symptom of prototypicality, not its cause” (Taylor, 2003: 56). A prototype is likely to have originated in our innate ability to categorize. Despite the great exposure of a temporal sense caused by high frequency, we still perceive spatial relationship as the prototype of prepositions. In addition, the occurrence of spatial configuration, for example, *There is a pen on the desk*, may not be so frequent in language production, because, to anyone who sees the two entities and understands the relation, the spatial configuration is too obvious to describe in words. The example is expected to occur exclusively in reply to questions such as *Is there anything on the desk?* (Shortall, personal communication, 2007). However, as the spatial relationship is also applied to metaphorical senses, such as time, the concept of the locative sense in the use of prepositions is frequent and pervasive with figurative interpretations. Hence, I believe that frequency may still be to some extent a clue to discovering prototypicality.

Geeraerts (2007) favours the psychological hypothesis due to cognitive economy in categorization, that is, “[t]he most information can be provided with the least cognitive effort” (Rosch, 1977 cited in Geeraerts, 2007: 169), whereby a prototype can incorporate the members bearing similar nuances into an individual concept. For this reason, a core concept framed by language users has been sought by means of eliciting tasks (Cuyckens, Sandra and Rice, 1997; Levinson and Wilkins, 2006; Sandra and Rice, 1995) as well as the description of ‘introspective judgements’ written in a synonym dictionary (Geeraerts, 2007: 177). In order to find the central concept by eliciting tasks, a number of prepositions were examined by sorting tasks, similarity judgements and acceptability decisions.

As claimed by the hypotheses given on prototype discussed above, what is projected

at the centre of language users' categories may be a plausible candidate for a prototype. Nevertheless, the inferences from statistical evidence may to some extent contribute to specifying the prototype of a category. Taylor (2003: 119) asked 13 English speakers to write down as many sentences containing *over* as came to mind. The result was given as follows:

17 instances *He jumped over the wall*

13 instances *Come over here*

12 instances *The lesson is over*

10 instances *Do it over again*

Given that adverbial senses are included, the spatial sense appeared frequently. More importantly, in 11 instances out of 17, the sense of *He jumped over the wall* were written at the top of the answer sheet. In other words, the spatial sense occurred first to 65% of the subjects. It can thus be implied that frequency may to a certain extent relate to prototypicality. It is probably the case that what first comes to mind is spoken and written with greater frequency (the converse is also the case).

Taylor (2003: 64) suggests three approaches to specifying prototype:

- prototype-as-exemplar approach
- prototype-as-subcategory approach
- prototype-as-abstraction approach

The 'prototype-as-exemplar' approach seeks to specify prototype by concrete examples. Language users who are asked what a prototype is are capable of providing specific examples. As far as *over* is concerned, examples such as *The cat jumped over the wall* (Tyler and Evans, 2003a: 9) and *The plane flew over the hill* (Lakoff, 1987: 421) were cited as typical illustrations of *over*. Although these may be prototypes, it is unlikely that these sentences encourage the grouping in the category of any senses expressed by *over*. Due to 'cognitive

economy' (Ungerer and Schmid, 2006; 71), whereby we expend the least effort possible on categorization, it is unlikely that a large number of spatial configurations of *over* would be adopted as the prototype. For this reason, the prototype-as-exemplar approach is less likely to specify prototype (Taylor, 2003). Rather, a concept which entails a variety of senses of a preposition may serve as prototype in order to lessen the cognitive strain on language users.

The 'prototype-as-subcategory' approach aims to decode the attributes of the prototype. This view complements the hypothesis of Geeraerts (2007) and is adopted for analysing the spatial configuration and movement denoted by prepositions. First, at least two entities are involved in the relationship of prepositions: for instance, '*the cat*' and '*the wall*' in Tyler and Evans' example above. The features of the two components have been extensively investigated (Lakoff, 1987, Langacker, 1987; Tyler and Evans, 2003a) and the analysis is more fully discussed in section 2.3 Trajector and Landmark, below. The 'path' movement is considered a key attribute of the composition of the prototype sense of *over*. As in the above examples, '*the cat*' and '*the plane*' make a path trajectory in relation to the other entities, '*the wall*' and '*the hill*' respectively. It can be concluded that there are three elements generating the sense of prototype: two entities and the spatial/movement configuration. These three elements are analysed in more depth throughout this study.

The 'prototype-as-abstraction' approach, for its part, focuses on the abstract concept of the prototype. The theory holds that abstraction gives rise to a mental representation of the concept. This seems to conform to the psychological hypothesis suggested above by Geeraerts (2007), since the judgement depends on the introspection and intuition of language users. The mental representations of *over* (Figure 2.4 below) are likely to be the outcome of the 'prototype-as-abstraction' and 'prototype-as-subcategory' approaches. The spatial relations established by preposition *over* are abstractly conceptualised by eliminating trivial descriptions: specifically, the colour of the box and the details of the town are withdrawn from

mental representation. Such a process of selection is defined as ‘schematisation’ (Talmy, 2007: 766, cf. ‘idealisation’, Langacker, 1987: 803). Moreover, the diagrams, which are the reflection of the mental image, also indicate the key constituents of the spatial configuration of *over*. The example below (Figure 2.4), *The plane flew over the town*, illustrates that one entity is ‘*the plane*’, which moves and is located at the centre of attention; the other, ‘*the town*’, stays and remains as the background; and the broken arrows show the movement of the plane. As a consequence, it may be concluded that the relationship expressed by prepositions is conceptualised into an abstraction with the essential components highlighted.

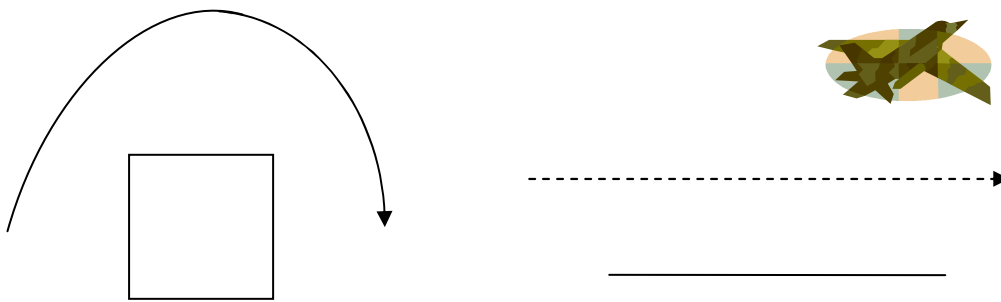

Figure 2.4 Mental representations of *Jump over the box* and *The plane flew over the town* (Lindstromberg, 1998:113)

To sum up, the prototype of prepositions is likely to be specified on a psychological hypothesis (Geeraerts, 2007) and also by sub-categorization and abstraction (Taylor, 2003). The internal and external structures of the prototype can be illustrated by the mental representation, which derives from the intuition of language users. The simplified model of prepositions is decoded into the three main components: one entity being the focus of attention, another the background and the third the indicator of the spatial relationship and movement. This section has provided accounts of the central member of a category and we discuss non-central members in the following section.

2.2.2 Semantic network

Semantic network closely relates to the prototype theory. Prototype effects are a phenomenon in human categorization which make a particular member of category prominent and as a result makes the other members less prominent⁴. However, the low profile members are associated with the prototype and the connections constitute an interrelated network with each member of the category sharing a common attribute.

Lakoff (1987: 74-75 and 83; 2007: 134) provides an illustrative example of the structure of a semantic network. Nowadays various kinds of mother exist in society: namely, >stepmother<, >adoptive mother<, >birth mother<, >natural mother<, >foster mother<, >biological mother<, >surrogate mother<, >unwed mother< and >genetic mother<. An idealised mother, on the one hand, who gives birth to a child, brings it up, possesses custodial rights and satisfies other conditions, is the most likely to be the prototype of the ‘mother’ category⁵. The given types of mother, on the other hand, are categorized into non-prototypical members of the category, largely because they do not share the attributes which the prototypical mother is expected to possess. These peripheral members do not irrationally form the network under the name of mother. Rather, particular attributes function to associate the peripheral members with a central member and the other members. For example, the attribute of nurturance serves to relate >stepmother<, >adoptive mother< and >foster mother<. Giving birth is the attribute connecting >birth mother<, >natural mother< and >surrogate mother<. And a genetic issue concerns the link between >biological mother< and >genetic mother<. These attributes associating the members of a network are called ‘clusters’ (Lakoff, 2007: 136). The clusters of nurturing the child, giving birth and sharing genes are located at the

⁴ Lakoff (2007: 136) argues that there are three sources of prototype effects: graded scale models whereby prototype is determined by measureable features, such as *rich*; classical models which depend on standards in society, for example, *bachelor*; and cluster models, which are discussed in the main text above.

⁵ ICM is the abbreviation of Idealised Cognitive Model proposed by Lakoff (1987). It is a mental representation of a typical theory and knowledge of the world to which language users belong (Evans 2007a).

centre of the related members and associate with the prototype, an idealised mother. The connection of the central and peripheral members through clusters establishes a ‘radial category’ (Lakoff, 1987: 91), as illustrated in Figure 2.5 below.

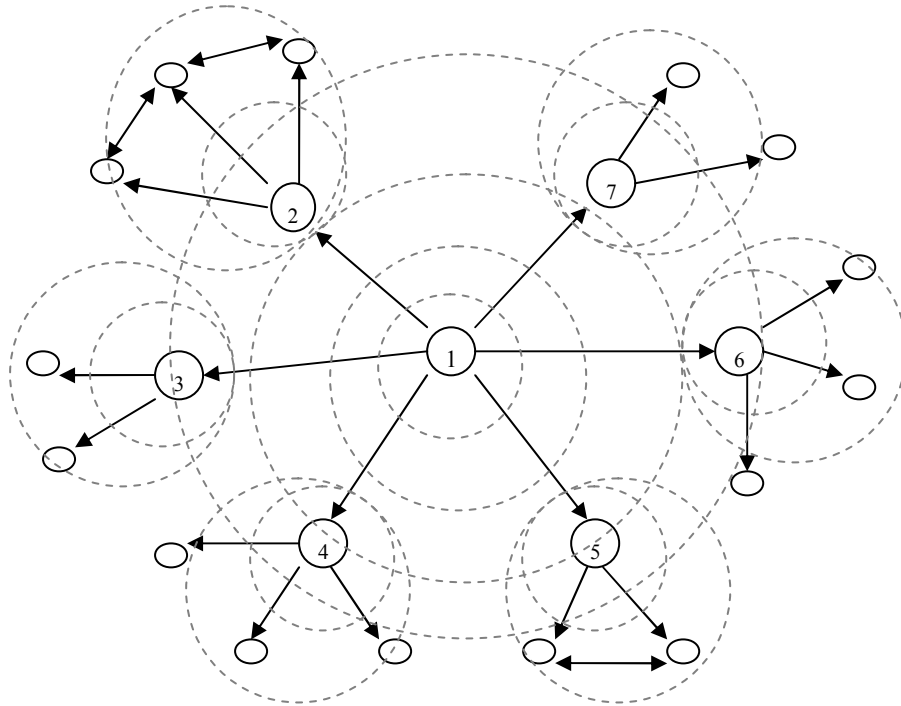
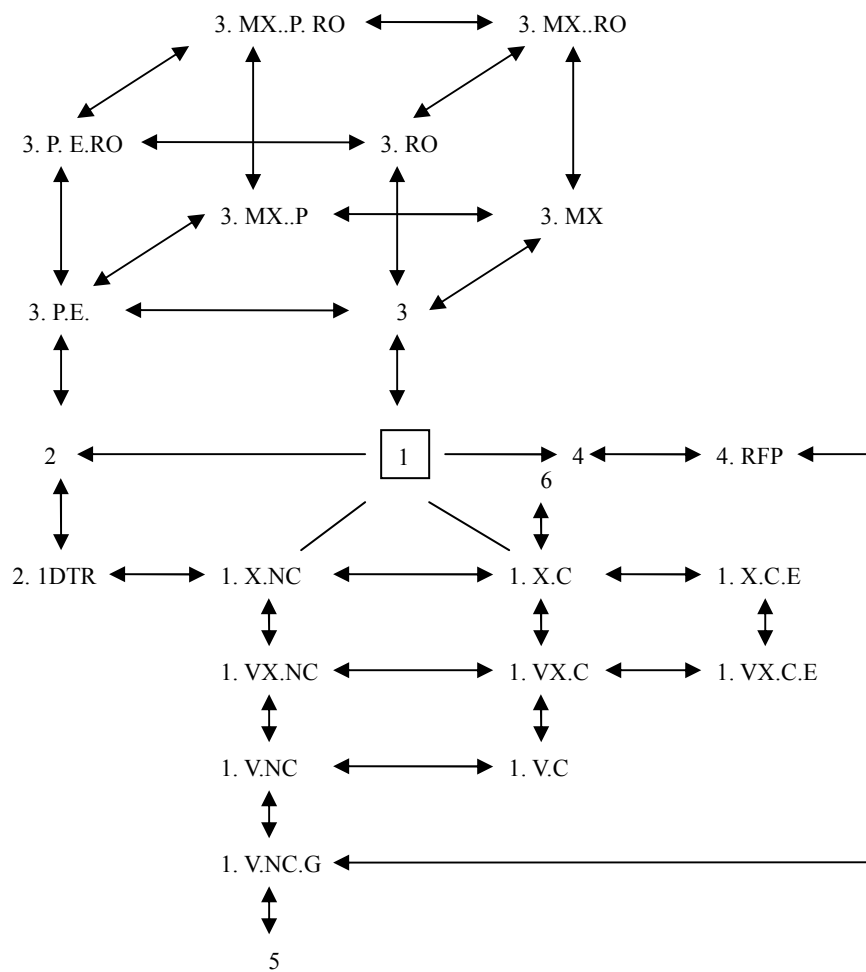

Figure 2.5 Idealised semantic network with radial category (adapted from Sandra and Rice, 1995: 96; Rice, 1996: 137)

The numbered clusters are associated with the prototype of mother located at the centre of the network. One of the numbered clusters (number 2), which corresponds to the attributes of nurturing the child, relates >stepmother<, >adoptive mother< and >foster mother< to one another in the cluster and at the same time the members in the subcategory interrelate by sharing certain attributes with each other. The extensions from the prototype to clusters and via the clusters which function as secondary centres are described as radial.



P, path; E, end-point; MX, multiplex; RO, rotated; 1 DTR, one dimensional; RFP, reflexive path;
X, extended; V, vertical; C, contact; NC, no contact; VX, vertical extended

Figure 2.6 Semantic network of over by Lakoff (1987: 436)

A radial semantic network is applicable to the description of prepositions. Lakoff (1987: 436) also provides an account of the semantic network of *over*, as illustrated in Figure 2.6 above. The network was established on the basis of schemas which represent a mental representation of different senses of *over*: schema 1 ‘above-across’, schema 2 ‘above’, schema 3 ‘covering’, schema 4 ‘reflexive’, schema 5 ‘excess’ and schema 6 ‘repetition’. The function of schemas in the network seem analogous to the clusters which specify the attributes of members. Schema 3, ‘covering’, for example, is associated directly and indirectly with the

members of the sub-category. The attributes of the cluster are decomposed into MX (multiplex), P (path), E (end-point) and RO (rotated) and their combination gives rise to the different ‘covering’ senses assigned to the members. For example, the covering sense of *over* in *The guards were posted over the hill* (Lakoff, 1987: 428) is assumed to have the attribute of multiplex (MX) in that scattered points, *the guards*, cover an entity which is construed as a planar, *the hill*. In addition to the MX, the path attribute (P) contributes to conveying the covering by the sum of movements of an entity, as in *I walked all over the hill* (ibid.: 429).

In contrast, the semantic network of *over* established by Tyler and Evans (2003a, Figure 2.7 below) suggests that the clusters of ‘A-B-C trajectory’ and ‘up’ should be extended to the derived senses. The former cluster represents the movement from the starting-point through the mid-point to the end, while the latter indicates vertical lifting. The mental representation of the A-B-C trajectory is hypothesised as being associated with those of the temporal sense, the completion and the transfer. It should be noted that peripheral senses can emerge indirectly from the prototype. The ‘over-and-above’ sense, for example, is in the network through the extension from the ‘up’ cluster and the ‘more’ sense. This ‘meaning chain’ (Taylor, 2003: 110) is likely to contribute to the establishment of a semantic network, since a derived sense cannot be linked to the prototype without the interference of the cluster and senses in the network.

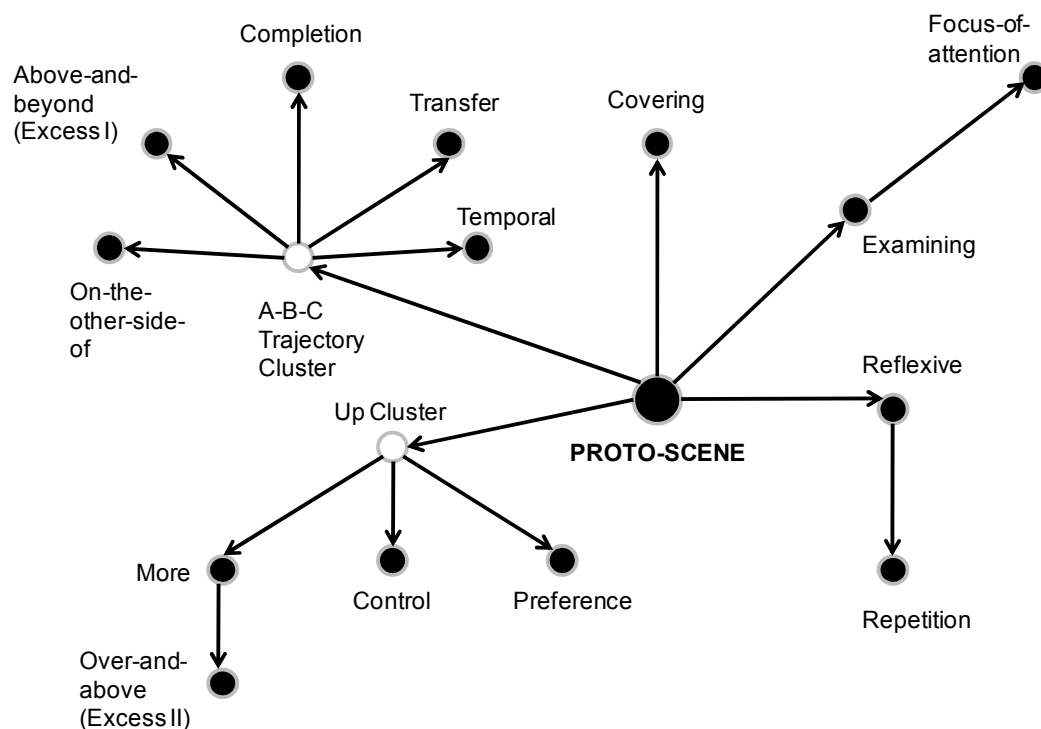

Figure 2.7 Semantic network of *over* by Tyler and Evans (2003a: 80)

The semantic network of *over* which is given here shows that the prototype at the centre is surrounded by the peripheral senses and connected through clusters which represent attributes and which group similar senses together. The referential hypothesis suggested by Geeraerts (2007) is likely to be supported by a semantic network where the prototype shares more attributes than the peripheral members of the category. In the following section we explore two entities involved in relationships expressed by prepositions.

2.2.3 Trajector and landmark

The locative sense is highly likely to be prototypical in terms of the senses of prepositions and the semantic network is assumed to consist of the prototype and the derived senses. The components of the prototype have to be understood before an association can be found between the central and peripheral senses. As the diagrams of the prototypes of prepositions are simply illustrated (Figure 2.3 above), the spatial relationship is established by at least two

of the entities involved: one is the centre of attention and likely to be movable, and the other is the background and referenced to the first. The cognition of making one thing ‘foregrounded’ (Lee, 2001:4) and at the same time holding the other in the background is a common phenomenon of human perception. This contrast is based on a basic antithesis in cognition: ‘figure’ and ‘ground’ (Herskovits, 1988; Langacker, 1987; Talmy, 2000). A well-known optical illusion, Rubin’s vase (Figure 2.8 below), shows how our construal alters in the relationship between figure and ground. Anyone who sees the black as salient finds two faces in profile. Alternatively, anyone who perceives the white as highlighted sees a white vase. Cognitive linguists posit that human perception, which interacts closely with the world, is actively involved in establishing the meaning of a word. In other words, meaning represents the way in which a language user ‘construes’ an entity or event as a result of perceptions (Tsuji, 2003: 22). Construal, a creative ‘way of seeing’ (Evans and Green, 2006: 467), is one of the essential and central notions in cognitive linguistics. What is construed becomes ‘conceptualised’ (Langacker, 1989) – coding reality as a concept, from the language user’s viewpoint – and is assigned to a language form as its meaning, based on human cognition and experience. ‘Conceptualisation’ in cognitive linguistics is deemed equivalent to the meaning of language (Langacker, 1987).



Figure 2.8 Rubin’s vase

The relationship between figure and ground is frequently observed in language. In terms of the relations, such as subject and object; adjective and qualified noun; and main clause and subordinate clause, one is foregrounded and the other is backgrounded (Langacker, 1987). Figure and ground applied to prepositions are coined as the ‘trajector’ and the ‘landmark’ (ibid.: 231). For example, the configuration of entities denoted by the preposition *in* indicates the thing in the container as the ‘trajector’ and the container as the ‘landmark’ (Figure 2.9).

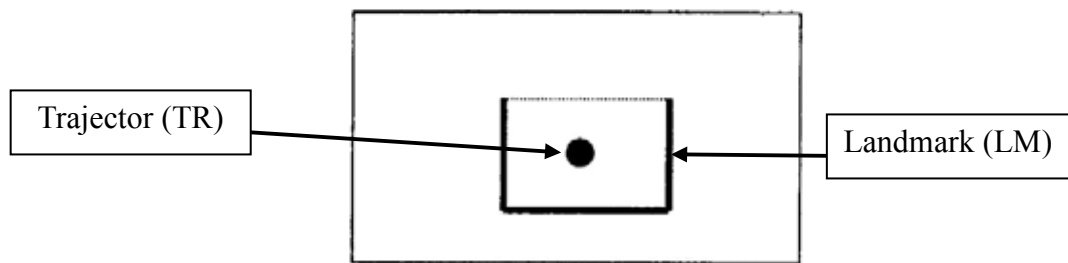

Figure 2.9 Trajector and landmark (adapted from Tyler and Evans, 2003a: 184)

The landmark serves as a reference object to the trajector and is characterised as a large, fixed object in the spatial configuration of the preposition (Herskovits, 1988). The nature is reflected in the noun phrase following *near* as in example (1) below. The smaller object, as landmark, *bicycle*, is expressed by a different phrase pattern, *where the bicycle is*, as in the paraphrase (ii). This is because we perceive that the first sentence violates a general law of landmark in relative size and immovability. Sandra and Rice (1995) advocate that the nature of the landmark is important to the analysis of the locative sense of prepositions.

- (1) (i) *Mary’s house is near the bicycle.
(ii) Mary’s house is near where the bicycle is.

(Herskovits, 1988: 274)

Talmy (2007) recounts the asymmetry between trajector and landmark, which in his account are named ‘primary object’ and ‘secondary object’ respectively⁶. The trajector (TR, hereinafter) is characterised as movable, small, simple, of great relevance, salient and dependent, whereas the landmark (LM, hereinafter) is described as a reference entity, relatively located, large, complex, of less relevance, backgrounded and independent (Table 2.1 below).

<i>Primary object</i>	<i>Secondary object</i>
<ul style="list-style-type: none"> · Has unknown spatial (or temporal) properties to be determined · More movable · Smaller · Geometrically simpler (often pointlike) in its treatment · More recently on the scene/in awareness · Of greater concern/relevance · Less immediately perceivable · More salient, once perceived · More dependent 	<ul style="list-style-type: none"> · Acts as a reference entity, having known properties that can characterise the primary object’s unknowns · More permanently located · Larger · Geometrically more complex in its treatment · Earlier on the scene/in memory · Of lesser concern/relevance · More immediately perceivable · More backgrounded, once primary object is · More independent

Table 2.1 Features of primary object and secondary object (Talmy, 2007: 771)

Despite the fact that the description is comprehensive, some of the features require discussion. For example, the description that the TR is geometrically simpler than the LM implies that the TR is simple and non-multilayered, unlike the LM of Figure 2.9 above; a box is geometrically decomposed into the inside of the entity, the outside and its boundary. But in fact the TR also has a complex structure in its spatial relation. As shown in Figure 2.10 below, the TR in the relation of *through* to the LM consists of three elements: the first part at the outside of the LM (TR A), the inside (TR B) and the second part of the outside (TR C). As in example (2) below, a spatial configuration of protrusion expressed by *through* indicates that more than one element of the TR exists both inside and outside the LM: a part of the route

⁶ Herskovits (1988: 274) designates the Figure entity as the ‘located object’ and the Ground as the ‘reference object’.

goes from the outside towards Brussels (TR A), another part of the route crosses the inside of the LM (TR B) and the other runs away from the city (TR C).

- (2) I think it [the route] actually goes through Brussels, doesn't it, the motorway.⁷
<S1A-021 #197>

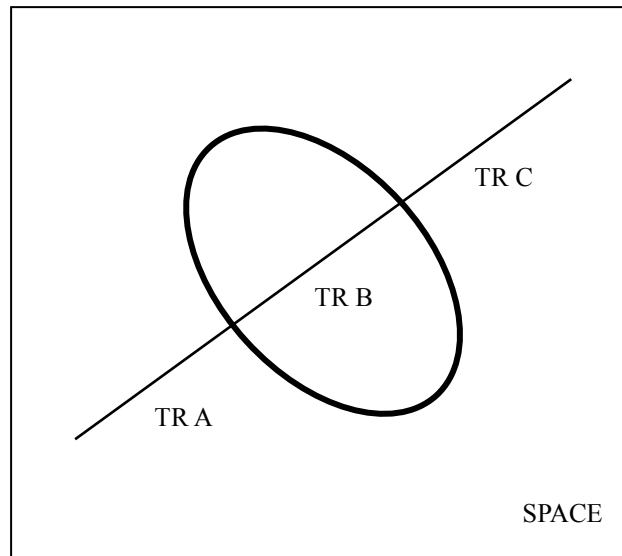

Figure 2.10 Trajectory and landmark of *through* (Langacker, 1987: 239)

The nature of the TR and the LM is likely to affect the choice of prepositions. As seen in example (3) below, the TRs are different but have the same LM, *tube*, in both. In terms of the relation between TR and LM, the only exception, *snake*, is unable to occur with preposition *through*. However, given that the TR and the LM are essential to the choice of prepositions, there is a possibility that the verb also requires the spatial sense to be generated. The sentences of example (4) have the same trajectory, *bike*, and the same verb, *sped*, but it appears with different prepositions, *through* and *into*, in accordance with the LMs, *tunnel* and *sports hall* respectively. This implies that the TR and LM are susceptible to co-occurrence with a particular preposition and this feature is reflected in the choice of prepositions. As a

⁷ The trajectory and landmark in relation to prepositions are shaded in the example sentences.

consequence, I would like to hypothesise that the combination of TR and LM is likely to predict the sense of the preposition, taking into consideration that verb is also an influential factor in the sense.

- (3) (i) The ball rolled through the tube.
- (ii) The trickle flowed through the tube.
- (iii) *The snake lay through the tube.
- (4) The bike sped through the tunnel.
The bike sped into the sports hall.

This section has reported how the proposition of TR and LM relate to the description of the spatial relation expressed by the prepositions. I conclude that, on the basis of the asymmetric nature of the TR and the LM, the combination could to a certain extent indicate the senses of the prepositions. However, we still observe some evidence of the locative sense. In the following sections I demonstrate that this approach of combining TR and LM for the task of describing the preposition's senses is also reasonable for the metaphorical senses.

2.3 Embodiment and image schema

Until recently, body and mind were considered to be independent faculties in the Western philosophical tradition. The body was believed to distract the mind and to be inferior in the hierarchy of the human system from the time of the ancient Greeks, such as Plato and Aristotle (Gibbs, 2006). In a similar vein, Descartes (1984) claimed the dualism of body and mind: that is, our body is separate from the mind, where our thoughts, desires and volitions originate. Human bodies were seen as being isolated from human minds and the world where we live. Moreover, as Saussure argues, it is believed that the relationship between an entity and its name is arbitrary and no particular reason underlies any connection between them. The

two sets of dualities led to the separation between ‘body and mind’ and that between ‘language and the world’. Yet, opposing the traditional belief, Merleau-Ponty (1962) and other philosophers, such as Kant, Husserl and Heidegger in the school of phenomenology, underline the importance of embodied experience to the understanding of the world (Verela *et al.*, 1993) and argue that the interaction between them, given the existence of bodies, gives rise to the rationale of our knowledge of the world.

‘Embodiment’ is the theory of human cognition which suggests that our bodily experience, which we recurrently undergo in everyday life, provides the rationale and foundations for the conceptualisation of the external world. Cognitive linguists hold that body and mind are closely interrelated and in turn posit that linguistic structure is determined on the basis of embodied experience (Johnson, 1987; Lakoff, 1987). As far as prepositions are concerned, research in developmental psychology shows that young children are likely to understand the concept of *in*, that is, ‘containment’, through recurrent experiences of interaction with certain things around them. Their experiences, such as putting a thing in a box or a bag, and coming into a room, are hypothesised to form the basis of understanding the concept of containment. As children grow up, the concept of physical relationship is eventually extended into atypical containment, as in *John is in England* (Vandeloise, 2003: 419), and non-physical containment, as in such time expressions as *in the afternoon*.

Most of the spatial relationship of the prepositions can be represented by the trajector and the landmark. For instance, containment denoted by preposition *in* is decomposed into ‘content’ (TR) and ‘container’ (LM) and support denoted by *on* into ‘bearer’ and ‘burden’ (Vandeloise, 1994; 2003: 394). The concept of prepositions is bodily experienced through the spatial relationship composed of the TR and the LM and the concept of the physical configuration is metaphorically projected onto the non-physical relationship. To put it another way, the metaphorical sense of prepositions shares a certain number of features of the spatial

relationship; the bodily-experienced relationship of the TR and the LM is applied to the figurative uses of prepositions. For example, the experiment conducted by Beitel *et al.* (1997) shows that a metaphorical support conveyed by *on*, as in *The family depends on the father*, was understood in a similar fashion to an example of physical support, as in *The vase is on the table* (see page 36). I would then argue that analysis of the TR and the LM is essential in order to interpret not only the physical but also the metaphorical sense of prepositions. However, a question arises as to why we construe most of the usages of *in* as derivatives of containment. The abstract image of containment which we retain helps us with the interpretation of a number of types of containment.

‘Image schemas’ are a set of conceptual templates which help us to understand the vast variety of spatial and metaphorical relationships which we recurrently experience in everyday life by means of making them converge into a general relationship⁸. Image schemas, which are based on embodied experiences, help us to structure abstract images (Johnson, 1987). For example, we bodily experience the concept of containing by seeing something in a container and finding ourselves in a closed space. The image schema of container, which derives from such embodied experiences, is applied to understanding an abstract containing, as in *All mistakes point up the limitations inherent in the technology* (Francis *et al.*, 1986: 446, my underlining). Drawing on the argument of Immanuel Kant, Johnson (1987) explains image schemas by comparing them to a geometric figure: if you imagine a triangle, the image is unlikely to precisely correspond to any triangle which we might observe in the real world. This is because triangles have different sizes of angles and sides of different lengths. However, we construe a triangle-shaped object as a triangle with the help of the general image which is retained in our thought. Similarly, image schemas represent the basic concepts which are

⁸ Johnson (1987) calls image schemas ‘image schemata’. In this study I will employ ‘image schemas’ as it is often found in the research.

repeatedly experienced through kinaesthetic interactions with objects in the real world. Image schemas are claimed to be pre-linguistic concepts, because some experiments suggest that babies who do not speak are familiar with the function of container (Mandler, 1992, Vandeloise, 2003). The spatial relationship of prepositions, which consists of the TR and the LM, is closely related to image schemas: namely, *in* can be conceptualised into ‘container’, *on* into ‘surface’, and *over*, as in *The cat jumped over the wall*, into ‘path’.

CONTAINER	BALANCE	COMPULSION	BLOCKAGE	COUNTERFORCE	RESTRAINT REMOVAL
ENABLEMENT	ATTRACTION	MASS-COUNT	PATH	LINK	CENTRE-PERIPHERY
CYCLE	NEAR-FAR	SCALE	PART-WHOLE	MERGING	SPLITTING
FULL-EMPTY	MATCHING	SUPERIMPOSITION	ITERATION	CONTACT	PROCESS
SURFACE	OBJECT	COLLECTION			

Table 2.2 List of image schemata (Johnson, 1987: 126)

Image schemas are topologically flexible, yet have a certain tolerance level for the appropriateness of the concept. For example, in terms of containment, we express a spatial relationship; even in cases such as Figure 2.11 below, we might say *The pear is ‘in’ the bowl*.

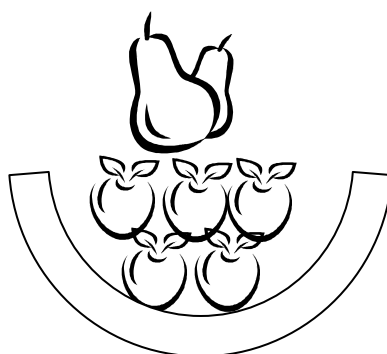

Figure 2.11 Pear in the bowl (Vandeloise, 1994 :171)

Strictly speaking, the pear is located outside the sphere of the bowl, but we construe the relationship of containment as being established between the fruit and the container. This suggests two different aspects of image schemas. Containment can be topologically

interpreted to the extent that the TR and the LM functions appropriately to the image schema. The term ‘topology’ originates from geometry and means that the spatial relationship can be extended flexibly to the point where it breaks down. Take Figure 2.11, for example: the container (LM), *the bowl*, is construed to be extended into the sphere of the content (TR), *the pear*. The reason why the relationship of containment does not fail is that the LM ‘functions’ as container vis-à-vis the TR although the TR is located outside the LM. The nature of the TR and the LM determines whether the function is performed. Vandeloise (1994: 173, my underlining in (5) and (6) below) points out that a bulb and a cap can acceptably establish the relationship of container, because the LM, *the cap*, serves to hold the TR, *the bulb*, whereas the LM, *the cap*, cannot stand as the container for the TR, *the bottle*. As a result, it could be implied that the nature of the TR and the LM allows us to construe the spatial configuration topologically. Hence, I would argue that the combination of the TR and the LM is essential for interpreting prepositions, since their relationship to each other indicates the function.

(5) The bulb is in the cap.

(6) *The bottle is in the cap.

The function of the TR and LM is also reflected in the way in which we construe them. ‘Image-schema transformations’ (Lakoff, 1987, Johnson, 1987) occur when a particular aspect of the TR, the LM or the path movement is highlighted. Take (7), for example: the scattered places where *many sanctuaries* are located are construed as an aggregation of places as though they loosely covered *the country*, but in fact the actual appearance of the TR in the external world is that of a set of points. Such alteration of construal is described as ‘multiplex to mass’ transformation (Johnson, 1987: 26). Likewise, the image-schema transformation is seen in example (8) below, where *the hands of Stevenson*, as the LM, are construed as a space which has a mass volume which the TR, *the ball*, can traverse.

- (7) ...many sanctuaries that at that point had existed all over the country and the free access,.. <S1B-001 #004>
- (8) ... and it [the ball] goes through the hands of Stevenson who ran off the boundary. <S2A-013 #006>

The other transformations are related to the path schema which is often represented by prepositions *over* and *through*. The image-schema transformation of ‘following a trajectory’ (ibid.,: 26) encourages us to see the path of the TR as a continuum from the starting point to the end-point. As seen in (9), the trajectory which the TR, *the route*, makes is construed as a single path through *Brussels* to the end. It should be noted that, by definition, *the route* functions to allow vehicles to travel from one place to another, and therefore it is associated with the concept of the continuum of the trajectory. While the following trajectory transformation underlines the whole journey of the TR on the one hand, the ‘path-focus to end-point focus’ transformation (ibid.: 26), on the other hand, foregrounds the destination of the TR’s trajectory on its own. Example (10) shows that the TR, *the vault*, is located at the end-point from the participant in the scene, *you*, and the speaker of the utterance, through the LM, *the main sanctuary area*. As a result of taking a look, the trajectory of seeing ends up at the end-point where the TR corresponds with the mid-point and the rest is grounded. As we have seen, image-schema transformations are deeply involved in the interpretation of prepositions. For this reason, the nature and function of the TR and the LM should be examined to analyse the senses of prepositions

- (9) I think it [the route] actually goes through Brussels, doesn't it, the motorway. <S1A-021 #197>
- (10) Uhm, you see, of course, the detail here of, the of of of, the vault that’s over the main sanctuary area,... <S2A-060 #066>

A seminal study conducted by Beitel *et al.* (1997) examining the embodiment and the attributes of preposition *on* demonstrates that the senses of the preposition are controlled by a number of image schemas which are closely associated with embodied experiences. In the first experiment, the subjects were asked to stand on a table and rate the appropriateness of image schemas based on the embodied experience. As a result, five image schemas were chosen to represent the concept of *on*: SUPPORT, PRESSURE, VISIBILITY, COVERING and CONSTRAINT. Subsequently, thirty-seven sentences containing locative and metaphorical uses of *on* were scored according to their relevance to the five image schemas. For example, the locative sense, as in *The vase is on the table*, was rated SUPPORT (6.46), PRESSURE (4.58), VISIBILITY (6.54), COVERING (4.75) and CONSTRAINT (4.29). Finally, further subjects separate from those in the previous experiments were asked to classify the thirty-seven sentences and the different usages appeared to be grouped in a way which related closely to the classification of the five image schemas – 82% of the uses were correctly classified in accordance with the image schemas. These results provide us with a number of implications about the relationship between prepositions and image schemas. First, image schemas exist and intuitively associate the concept of prepositions with kinaesthetic experiences that we repeatedly have in interactions with the external world. In the experiment, the experience of sitting, rocking and various interactions with a table encouraged the subjects to identify the image schemas of *on*. Secondly, image schemas are innately available in human cognition. As the third experiment confirmed, without any indication of image schemas we can differentiate image schemas in the same surface structure yet with distinctive senses of *on*. Most importantly, the senses of prepositions can be represented by more than one image schema; or rather, the combination of image schemas and the degree of relatedness are likely to predict the senses. Similar senses of the preposition share the rating pattern of the image schemas. Figure 2.12 below illustrates the fact that the dependence sense of *on* has an

identical distribution pattern in the ratings of the five image schemas. High ratings were given to the aspect of SUPPORT (6.17 of *The family depends on the father* and 5.79 of *He lives on a pension*). Medium ratings were given to PRESSURE (4.04 and 3.17, respectively) and CONSTRAINT (4.00 and 4.88), and low ratings were given to VISIBILITY (2.33 and 1.83) COVERING (1.67 and 1.92).

	SUPPORT	PRESSURE	VISIBILITY	COVERING	CONSTRAINT
<i>The family depends on the father.</i>	6.17	4.04	2.33	1.67	4.00
<i>He lives on a pension.</i>	5.79	3.17	1.83	1.92	4.88

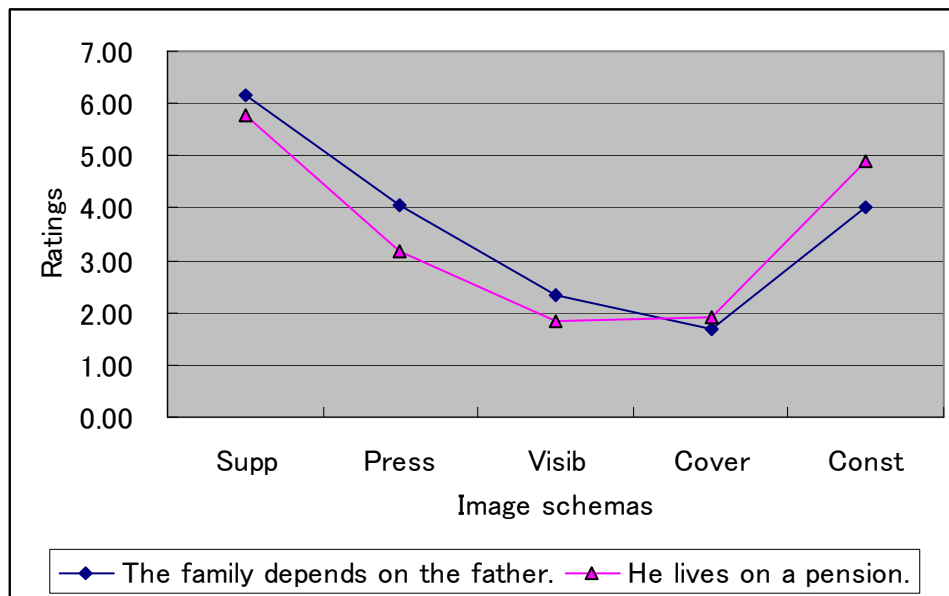

Figure 2.12 Distribution patterns of the dependence sense of *on* (adapted from Beitel *et al.*, 1997)

Figure 2.13 below shows that the locative sense differs in the distribution pattern of the image schemas; however, it almost corresponds to the dependence sense in terms of high and medium ratings, namely, SUPPORT (6.46), PRESSURE (4.58) and CONSTRAINT (4.29). To put it more accurately, the locative sense, as in *The vase is on the table*, is assigned no low ratings in the five image schemas, including VISIBILITY (6.54) COVERING (4.75). Conversely, it is no surprise that VISIBILITY and COVERING are relatively absent in the

dependence sense compared to the locative. Given that the extent of the attribution is distinctive, the distribution pattern of image schemas relates to different senses of the preposition. Not all the attributes, which are represented by the image schemas are possessed by any sense of *on*; rather, some of the attributes relate to a particular sense, namely, SUPPORT, PRESSURE and CONSTRAINT, which relate to the sense of dependence. Sharing some, but not all, of the attributes is likely to feature as a family resemblance in categorization, indicating that a member of a category has a partial similarity, in common with the other members.

	Supp	Press	Visib	Cover	Const
<i>The family depends on the father.</i>	6.17	4.04	2.33	1.67	4.00
<i>He lives on a pension.</i>	5.79	3.17	1.83	1.92	4.88
<i>The vase is on the table.</i>	6.46	4.58	6.54	4.75	4.29

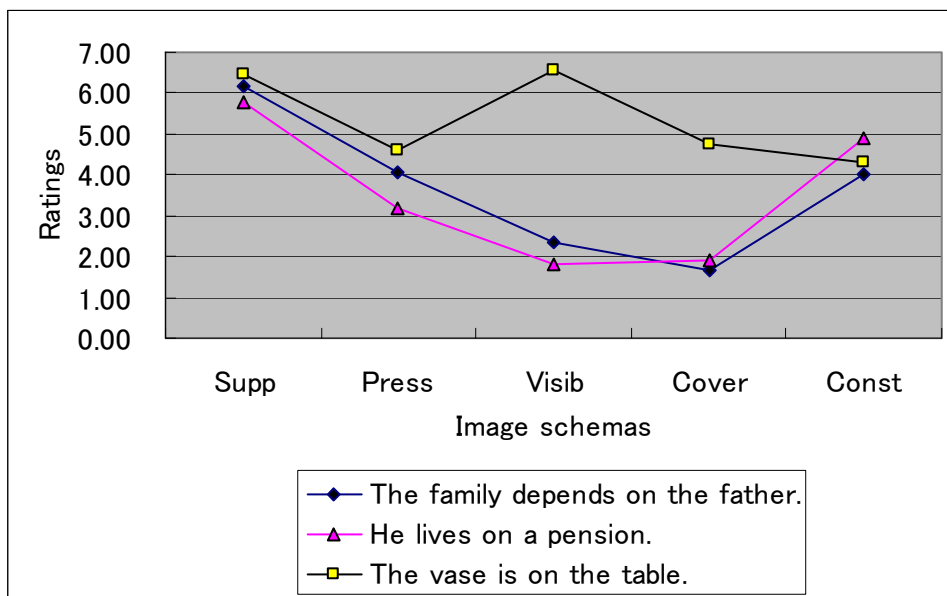

Figure 2.13 Distribution patterns of the locative and dependence senses of *on* (adapted from Beitel *et al.*, 1997)

Not only can the senses of the preposition be decomposed into image schemas, but those of the verbs can also be decomposed into particular image schemas. Gibbs *et al.* (1994) carried out similar experiments to those conducted by Beitel *et al.* (1997). One of these was

an experiment aimed at discovering the principal image schemas related to the concept of ‘*to stand*’. Their study produced some image schemas common to those of preposition *on* (Table 2.3 below). The two sets of twelve image schemas were chosen by the experimenters from twenty-seven image schemas suggested by Johnson (1987, see Table 2.2 on page 31). BLOCKAGE, CENTRE-PERIPHERY, LINKAGE, RESISTANCE and PATH were given relatively medium ratings for the image schemas of both ‘*on*’ and ‘*to stand*’. This may imply that the image schemas represented by the preposition can be triggered by the verb at the same time. For example, in *The clock stands on the mantel* (Gibbs *et al.*, 1994: 244), the locative sense is likely to be inferred at the same time from the CENTRE-PERIPHERY of both *on* and *to stand*. In the same manner, metaphorical standing as in *We stand on 30 years of experience* (ibid.: 243) is conveyed by the LINKAGE of the words. I would in turn argue that the analysis of the sense of prepositions should not be given for prepositions on their own, but that the contribution of the co-occurring verb should be examined too.

Preposition <i>on</i>		Verb <i>to stand</i>	
Image schemas	Ratings	Image schemas	Ratings
SUPPORT	6.43	BALANCE	6.83
PRESSURE	5.83	VERTICALITY	5.50
VISIBILITY	5.80	CENTER-PERIPHERY	5.21
COVERING	5.67	RESISTANCE	4.46
CONSTRAINT	4.50	LINKAGE	4.33
ATTRACTION	4.17	CONTAINER	4.29
CENTER-PERIPHERY	3.73	ENABLEMENT	4.21
BLOCKAGE	3.67	ATTRACTION	4.08
RESISTANCE	3.33	BLOCKAGE	3.92
LINKAGE	3.13	FULL-EMPTY	3.92
PATH	1.97	CYCLE	3.79
NEAR-FAR	1.77	PATH	3.21

Table 2.3 Ratings of the image schemas of *on* and *to stand* (Beitel *et al.* 1997: 248, Gibbs *et al.*, 1994: 238, my highlighting)

The hypothesis that the sense should be attributed to more than one word is the

central thesis of phraseology in corpus linguistics. The studies of image schemas in cognitive linguistics also suggest that the concept, which closely relates to the sense, arises from a phrase. Lindner (1983) examined about 600 cases of ‘verb + *out*’ (e.g., *TAKE out*, *SPREAD out*, *THROW out*, *PICK out*) and more than 1100 cases of ‘verb + *up*’ and concluded that a small number of image schemas indicate the concepts of almost all instances of verb-particle constructions. Technically speaking, *out* and *up* are not prepositions but are sometimes grammatically categorized as adverbs. However, supposing the words denote a spatial relationship, *out* and *up* are called ‘spatial particles’ (Tyler and Evans, 2003a: 61), and so is *over*. I would claim that no clear distinction between prepositional and adverbial *over* is made in the sense of *over*, which conveys locative and metaphorical uses. Once again, the involvement of other components, such as the verb, should be taken into consideration when exploring the sense of prepositions.

Let us turn back to an extension of the physical sense of *over*. The preposition figuratively denotes ‘more’ as in *If you are over age 60, ...* <W2D-004 #089>. It is claimed that the sense derived from the locative use may be one of the image schemas, namely, SCALE (Johnson, 1987: 121). However, it can be considered as a reflection of the MORE IS UP (Grady, 1997). In the following section, we will see the way in which the extension of the spatial sense of prepositions is extended into the figurative sense.

2.4 Metonymy and metaphor

Prepositions demonstrate not only a spatial relationship, composed of TR and LM, which can be bodily experienced, but also a metaphorical one. Take *over*; for example. It is used to indicate the sense of ‘more’, as in the example: *If you are over age 60, ...* <W2D-004 #089>. It also has a sense of ‘control’, as in *...when George Bush took over America ...* <S2B-021 #019>. These metaphorical senses do not indicate that the TR is physically located above the LM.

Technically, *you* are not located above *age 60*, nor is *George Bush* above *America*. However, the ‘more’ and ‘control’ senses are represented by the preposition *over*, largely because we construe them as being associated with the spatial relationship of *over*. In other words, the metaphorical sense of prepositions derives from the physical one, and metaphor and metonymy are to a large extent involved in the derivation of prepositional senses. In this section, we explore the way in which the spatial sense of prepositions develops into the metaphorical ones and metaphor and metonymy contribute to the development of the senses.

Metaphor is sometimes thought to be simply a rhetorical device which aims to make language imposing to readers. Lakoff and Johnson (1980), however, counter the traditional views of metaphor which have been dominant in Western thought since the time of Aristotle. The traditional theory of metaphor explains the example, JULIET IS THE SUN⁹, by claiming that *Juliet* and *the sun* are thought to share ‘similarities’: they are both shining; they make you warm; you cannot live without them; and so forth. For this reason, it was assumed that metaphor was made possible by virtue of the similar attributes of the elements involved. Cognitive linguists, however, cannot accept the assumption that metaphor works like this. The rationale of metaphor is not similarity; rather, it is argued, its nature is that characteristics are projected from element A onto element B. As shown in Figure 2.14 below, *Sun* is the concept (‘source domain’) which maps particular attributes onto the other concept, *Juliet* (‘target domain’). Not all the attributes of the source domain are available to be mapped onto the target domain. For instance, a distinctive attribute of *sun*, which causes sunburn eventually leading to skin cancer, is not recalled from the metaphor JULIET IS THE SUN; only certain attributes – but not every one - of the source domain are chosen to be mapped onto the target domain. Therefore, metaphorical mapping is inferred to be partial, not based on the whole (Lakoff and Johnson, 1980). Some particular attributes of the source domain are ‘highlighted’

⁹ The concept of metaphor and metonymy is represented as ‘A IS B’ in small capital font.

and mapped onto the target domain. The cognitive process, highlighting, is found in the process of making metaphor. As a result, it is argued that metaphor is not merely a rhetorical technique; it is rather the representation of cognitive activities.

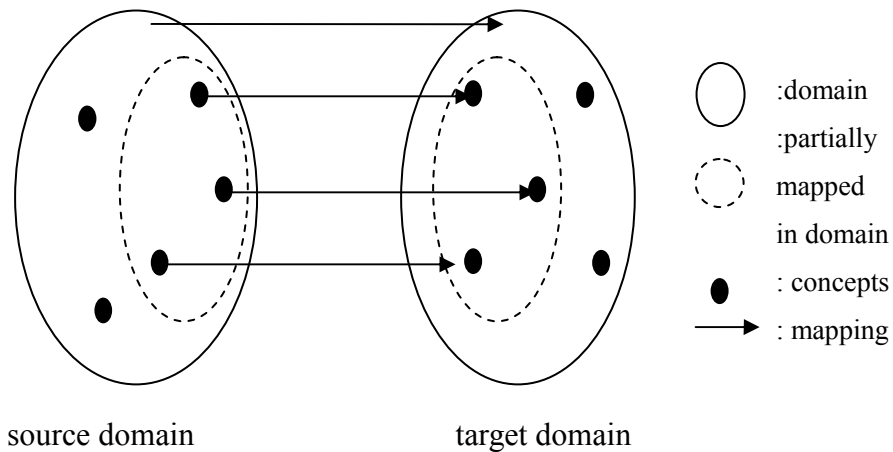

Figure 2.14 Mapping from the source domain to the target domain (adapted from Takao 2003: 202)

Metaphor, then, represents forms of cognition on the part of language users, such as construal and inference, and is not simply the oratorical manipulation of words. Metaphor is employed as a means of understanding an ambiguous concept by comparing it with a specific concept familiar to the language users. Such metaphor at the conceptual level (Evans and Green, 2006) may possibly result from the human mind’s subjective construal in order to discover a similar ‘attribute’ in the process of the ‘categorisation’ (discussed earlier in section 2.1) which links the two entities expressed in a metaphor. Metaphor to a large extent relies on ‘embodiment’ (see section 2.3 above), which is one means whereby we construe reality. For example, in the HEALTHY IS UP; SICK IS DOWN metaphor, as in *He fell ill* (Kövecses, 2002: 36, my underlining), the vertical direction sets up the concept of the metaphor on the basis of the embodied experience whereby we perceive upright as being good. ANGER IS HEAT, as in *As a*

child I had a real hot temper (Kövecses, 2000: 85, my underlining), is assumed to derive from the experience of increased body temperature when we get angry. Metaphor allows the projection of 'image schemas' onto abstract entities and associates an abstract relationship with our image schemas (Barcelona, 2000, Boers, 1996). In conclusion, metaphor is closely related to bodily experiences.

The concepts formulated by embodied experience correspond to image schemas, which function in nature as a source of metaphors (Evans and Green, 2006). Image schemas are a set of concepts which help us to understand what we encounter. The path schema indicates that an entity travels from one place to another. In terms of metaphor, an abstract entity, for example, can travel from one thing to another which is not supposed to be a container. This is called the 'conduit metaphor' (Reddy, 1979: 166). As shown in (11) and (12) below (ibid.: 166-67, my underlining), the abstract entity, *feelings*, is construed as capable of entering a person, *me*; likewise, *each concept* transforms into *words* through the process of change. In this case, change is construed as the path from one form to the other. Three types of metaphor are employed in terms of mapping abstract entities: 'ontological metaphor', 'structural metaphor' and 'orientational metaphor' (Lakoff and Johnson, 1980: 25). First, ontological metaphor contributes to our construal of seeing an abstract concept as a concrete entity: here, *feelings* and *concept* are seen as capable of moving. Secondly, structural metaphor provides a particular structure of the source domain with the abstract target domain: here, *feelings* are seen to be able to travel from person to person. Thirdly, orientational metaphor helps us construe the orientation between domains: here, *concept* is thought to change into *words*. These metaphors in which our construal is actively involved are likely to allow abstract entities to function in the same way as concrete ones. As has been seen, the metaphorical senses of *through* and *into* in the examples below seem to relate to the path schema which originates from the embodied experience of travelling from one place to

another.

- (11) None of Mary's feelings came through to me with any clarity.
- (12) You have to put each concept into words very carefully.

Metonymy, which can provide a word with semantic extensions, stands for an entity by referring to another adjacent to that entity (Momiya and Fukada, 2003: 83). In comparison with metaphor, which is accounted for by the nature of mapping on the basis of 'similarity', metonymy is assumed to be based on 'contiguity' and 'proximity' (Jakobson, 2003: 46; Kövecses and Radden, 1998: 37). In the sentence, *The ham sandwich is waiting for his check* (Lakoff and Johnson 1980: 35)¹⁰, for instance, *the ham sandwich* does not, in fact, literally stand for the food but by metonymy represents the person who ordered it. This could imply that the speaker foregrounds *the ham sandwich* as figure and the person as ground. It exemplifies the metonymy of THE PART FOR THE WHOLE, whereas the whole represents the part in the metonymy of THE WHOLE FOR THE PART. For example, in *My pencil broke* (Boers, 1996: 29), the broken part is not the whole of the pencil, but its lead point. A place, for example, metonymically implies an institution and those who work in this institution. An example of A PLACE FOR AN INSTITUTION, could be *The White House isn't saying anything* (Lakoff, 1987: 91), indicating that the American government or the president is the agent of the statement. An object, such as clothing, instruments and so forth, can stand for the user in metonymic fashion: AN OBJECT FOR THE PERSON USING IT, as in *The suits don't know how the assembly line operates* (Boers, 1996: 29), is the metonymy which represents that clothing refers to those who wear it. In addition to these metonymies, a variety of metonymies refer to a part of an entity, place and incident instead of the whole or vice versa. That is, a place can stand for the

¹⁰ Synecdoche, which refers to the part for the whole, can be categorized as a special usage of metonymy. Traditional rhetoric also foregrounds part of an entity out of the whole, as in 'There are a lot of *good heads* (=intelligent people) in the university' (Lakoff and Johnson, 1980: 36).

events which occur in the place, as in *Don't let El Salvador become another Vietnam* (Lakoff, 1987: 91), and a producer may represent the product, as in *Have you ever read Shakespeare?*

Principal types of metonymy are listed below:

THE PART FOR THE WHOLE

THE WHOLE FOR THE PART

A PLACE FOR AN INSTITUTION

AN OBJECT FOR THE PERSON USING IT

A PLACE FOR THE EVENTS

A PRODUCER FOR THE PRODUCT

(Boers, 1996; Kövecses and Radden, 1998; Lakoff 1987; Lakoff and Johnson, 1980)

Metaphor is hypothesised to map a set of attributes 'across' two different domains, that is, from the source domain onto the target domain, while metonymy is assumed to map the structure composed of attributes 'within' one domain which entails the whole phenomenon where the members of the metonymy appear (Boers, 1996; Goossens, 2003; Rice *et al.*, 1999). In other words, metonymical mapping takes place in a particular sequence where the members are seen. Take A PRODUCER FOR THE PRODUCT for example: Shakespeare wrote his work and his publication is at the end of the sequence of production. Such an imaginable sequence of incidents is defined as the 'idealized cognitive model' (abbreviated to 'ICM', Lakoff, 1987: xv), representing 'a theory about some aspect of the world' (Evans, 2007a: 104), which is the sequence of events proceeding as expected. Metonymy takes place within a single domain on the basis of the ICM, whereas in metaphor two domains are involved.

On the surface, metaphor and metonymy seem to be mutually exclusive categories because of the element of the mapping of two domains in metaphor and one domain in metonymy. However, this is not the case. In fact, metaphor and metonymy can be both used in

one figurative expression at the same time and the semantic extension is interwoven in a complex manner. Such a synthesis of metaphor and metonymy is dubbed as ‘metaphonymy’ (Goossens, 2003: 362). As in (13) below, *close-lipped* metonymically indicates that lips are the body part that speaks, instead of the whole upper body of the person speaking. This THE PART FOR THE WHOLE metonymy is associated with the metaphor, CLOSING LIPS IS SILENCE. *Close-lipped* suggests muteness, even though the people who are close-lipped, *the Brisbane Entertainment Centre* – this is also AN INSTITUTION FOR THE PEOPLE WORKING metonymy – do not actually close their lips. It can thus be implied that the CLOSING LIPS IS SILENCE metaphor develops from THE PART FOR THE WHOLE metonymy. Such interrelation between metaphor and metonymy is defined as ‘metaphor from metonymy’ (ibid.: 362). Another type of metaphonymy is ‘metonymy within metaphor’ (ibid.: 365). As shown in (14) below, the metaphor CATCHING EAR IS LISTENING is associated with the metonymy THE PART FOR THE WHOLE between the ear and the person, here, *the minister*. These examples of metaphonymy suggest that the co-occurrence of metaphor and metonymy is ubiquitous in semantic extension. In the same manner, the synthesis of metaphor and metonymy may give rise to an extension from the locative sense to the metaphorical senses of prepositions. Note, therefore, that the involvement of both metaphor and metonymy should be considered in analysing the semantic extension of prepositional senses.

- (13) The Brisbane Entertainment Centre is *close-lipped* about a Lion King booking... (Bank of English)
- (14) She caught the minister’s ear and persuaded him to accept her plan. (Goossens, 2003: 365)

The temporal sense of prepositions results from relatively conventional patterns of extension from the locative sense (Casasanto and Boroditsky, 2008; Evans, 2007b; Givón,

1979; Jackendoff, 1983; Lakoff and Johnson, 1980; Langacker, 1987; Radden, 1985; Talmy, 1988; Traugott, 1985). The TIME IS SPACE metaphor (Rice *et al.*, 1999: 107) is commonly used for a derived sense of prepositions. As indicated in Table 2.4 below, most of the prepositions, apart from *with*, *under*, *off* and *out of*, have a temporal sense which is highly likely to be semantically associated with the locative sense.

	at	on	in	by	with	through	about	over	under	from	off	out of
time	+	+	+	+	-	+	+	+	-	+	-	-

+: use of the temporal sense -: absence of the temporal sense

Table 2.4 The temporal sense of prepositions (adapted from Dirven, 1993: 84)

The association was accounted for by physiological experiments carried out by Casasanto and Boroditsky (2008). The subjects were exposed to different kinds of stimuli in order to decide the lapse of time. In one experiment, the subject saw a line on a computer screen and heard the sound of a buzzer. As the line got longer, they felt that the time of the sound got longer too. The results of these experiments suggest that our temporal judgements are prone to change by obtaining irrelevant information about space. In addition, asymmetry between space and time was observed, in that the influence of space on time was more pronounced than that of time on space. As a consequence, it can be inferred that space may be the more fundamental of the two concepts. For this reason, it can be argued that the temporal sense is likely to be the foremost metaphorical extension from the prototypical locative sense of prepositions.

Despite my claim that time is the first derivation from space, it seems unlikely that the locative sense and the temporal are associated in any straightforward way (Rice *et al.*, 1999). In the experiment by Rice *et al.*, the subjects were asked to classify 50 different sentences containing *on* – 20 spatial, 20 abstract and 10 temporal – on a screen by moving them with a mouse to form groups of similar sentences. The results of the sorting task indicate

that the spatial and temporal use of the preposition are clearly differentiated; however, another factor is likely to contribute to the classification of different uses of prepositions. ‘Concreteness and abstractness’ also seem to be involved in grouping the prepositional senses of the spatial and temporal, as well as of the abstract. This may imply that the spatial and non-spatial senses of preposition should be analysed with consideration of a number of related factors.

Time is conceptualised when one treats one idea as a ‘moving’ object and the other as a ‘landscape’ across which events move (Rice *et al.*, 1999: 109). Evans (2007b: 751-53) points out that the concepts are relevant to cognitive models: ‘the moving time model’ and ‘the moving ego model’. The former indicates that time is moving while ego-centric people remain (Figure 2.15 below). In terms of the theory of spatial configurations, it can be suggested that time is highlighted as the trajector (TR) which shifts from the future through the present towards the past, while a person is backgrounded as the landmark (LM) of moving time. In (15), for example, the events, such as *Christmas*, *graduation* and *the deadline*, seem to come toward the ego. The latter demonstrates that the ego is the trajector which is located in the present and is moving towards the future (Figure 2.16); here, the person is highlighted and the time is backgrounded. In (16), for example, the ego, here *we* and *she*, seem to approach the events, here, *Christmas* and *the deadline*.

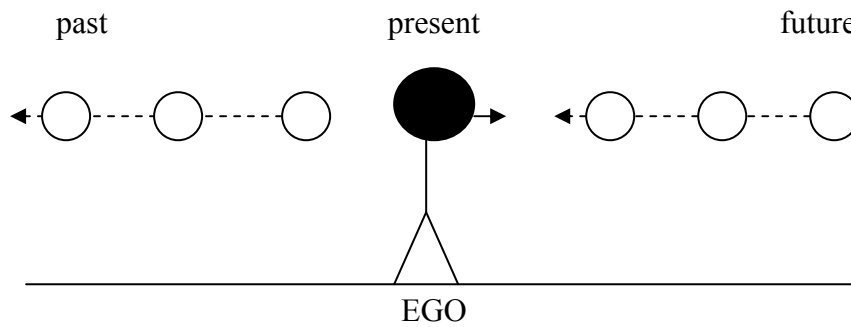

Figure 2.15 The moving time model (Evans, 2007b: 751)

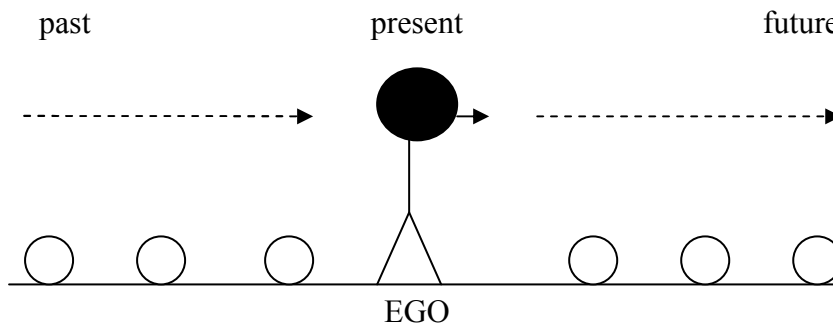

Figure 2.16 The moving ego model (Evans, 2007b: 753)

Both models are based on our construal about time whereby the language referring to time changes. The TRs of the moving time model are events, such as *Christmas*, *graduation* and *the deadline* and the landmarks are not observed explicitly, although they can be inferred as the content of the brackets of (15)a, *us*, indicates. However, the TRs of the moving ego model are pronouns referring to persons, here, *we* and *she*, and the LMs are clearly indicated after the verb or the preposition. As a result, I would argue that the different types of time expression relate to our construal and that the difference is likely to correspond with the occurrence of particular kinds of trajector and the phrase pattern in which the trajector and the landmark are observed in language. It follows that analysis of the TR and the LM, as well as the phrase pattern, is likely to provide a useful insight into the description of the metaphorical

sense, including the temporal sense, of prepositions.

- (15) a. Christmas is getting closer (to us).
b. Graduation is coming up.
c. The deadline has passed.

(Evans, 2007b: 753)

- (16) a. We're moving up on Christmas.
b. We're approaching my favourite part of the piece.
c. She's passed the deadline.
d. We'll have an answer within two weeks.
e. The meetings were spread out over a month.

(ibid.: 754)

As well as this extension to the temporal sense, the prototypical locative sense of prepositions develops into other metaphorical senses. Image schemas are likely to be essential to development. As Tyler and Evans (2003a) illustrate in Figure 2.17 below, the clusters of 'A-B-C trajectory' and 'up' function as the nodes of the derived senses from the locative sense of *over* ('proto-scene' in Figure 2.17). Technically, the A-B-C trajectory represents the path schema which indicates the movement from one place to another, and the upwards direction seems to be relevant to the 'scale' schema (Johnson, 1987: 126) which encourages us to measure increase and decrease. As discussed above, bodily experience is reflected in the conceptualisation of image schemas; that is, embodiment is likely to be the basis of the metaphorical extension.

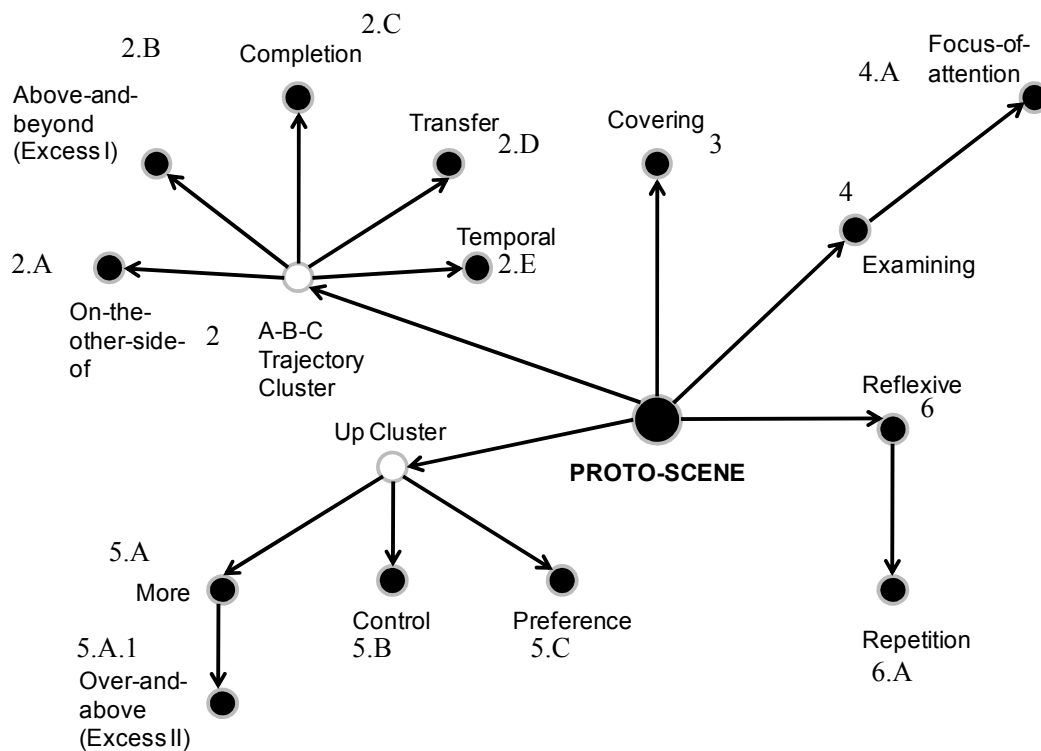

Figure 2.17 The semantic network for *over* (Tyler and Evans, 2003a: 80)

In addition to the image schemas, metaphor and metonymy are heavily involved in the extension of the metaphorical sense. One of the derived senses through the A-B-C trajectory cluster, the completion sense, as in *...the fighting is over relatively quickly* <W2E-006 #084>, seems to be mapped via the ACTIVITY IS JOURNEY metaphor. In other words, when we reach the end of a journey, we finish it. In the same manner, reaching the end of the A-B-C trajectory metaphorically represents the completion of the activity, *the fighting*. The ‘more’ sense, as in *If you are over age 60,...* <W2D-004 #089>, seems to derive from the MORE IS UP metaphor, which means that the vertical elevation corresponds to the increase of quantity or number. The control sense, as in *...when George Bush took over America...* <S2B-021 #019>, seems to originate from the metaphor of HIGHER IS STRONGER and at the same time metonymy is also involved in that *America* is inferred from A PLACE FOR AN INSTITUTION. This sense is likely to be developed through the metaphonymy of metaphor within metaphor. In terms of

the TR and LM that co-occur with the metaphorical senses of *over*, my data show that distinctive TRs and LMs are seen in a particular sense –discussed in detail in Chapters Six through Eight. For example, the LMs denoting number frequently occur in the ‘more’ sense and metonymic LMs which represent A PLACE FOR AN INSTITUTION are frequently found. This may be because the syntagmatic relationship based on word combination is related to specifying the metaphorical and metonymic sense (Dirven, 2003).

In conclusion, the metaphorical sense of prepositions is highly likely to derive from the spatial sense which functions as the prototype of the semantic network. Metaphor and metonymy are likely to contribute to the semantic extension by highlighting particular attributes of the source domain and mapping them onto the target domain. As metaphor and metonymy are claimed to be a fundamental cognitive process of conceptualisation (Goossens, 2003, Kövecses and Radden, 1998, Rice *et al.* 1999), the metaphorical senses of prepositions are unlikely to be arbitrary, but are rather systematically motivated by our embodied experiences and construal.

2.5 Phraseology

‘Phraseology’ in corpus linguistics is generally defined as the study of word combinations and phrases. As Wray (2002: 9) observes, units made up of a word combination have many names, such as ‘lexical phrases’ (Nattinger and DeCarrioco, 1992), ‘composites’ (Cowie, 1988), ‘phrasemes’ (Melčuk, 1988), ‘prefabricated routines and patterns’ (Krashen, 1981), ‘sentence stems’ (Pawley and Syder, 1983), ‘formulae’ (Peters, 1983), and ‘formulaic language’ (Wray, 1999), although several of these terms may be defined differently. Likewise, Hunston and Francis (2000: 7) cite a number of terminological variations referring to “sequences of morphemes that are more or less fixed in form”. Phraseology may be defined narrowly as linguistic phenomena, such as collocation (discussed in more detail below), phrases and

complement patterns (Hunston, 2002: 137-138). Cowie's wider definition, however, includes recurring complete utterances in discourse – e.g., *How are you?* as an unlikely enquiry about someone's physical state (Cowie, 1994). This study will adopt Hunston's focus on word behaviour, which interrelates with one or more constituent(s) in a string of text.

Even before phraseology began to be studied in corpus linguistics, it was largely perceived and postulated that units could be composed of more than one word, conveying a particular meaning which did not belong to the individual words within the unit. Such lexical units – namely, phrasal verbs (e.g. *look after*) and other idiomatic sequences (e.g. *spill the beans*) – were thought to assist learners of English with their production. They have, in fact, been effectively utilised in classrooms where English is taught. It is surmised that relatively fixed word combinations are used as short cuts in speech and written production and that these may assist the fluency of speakers and writers (Pawley and Syder 1983; Nattinger and DeCarrico 1992). However, accounts of the features of such units were at first limited and the combination of words and sequences within them was imagined to be firmly fixed.

It still remains unclear how multi-word sequences can be identified as units. Three explanations have been offered. First, because native-speakers can intuitively identify them, Foster (2001) carried out a study in order to identify what native-speaker intuition saw as fixed 'chunks'. Second, with the help of computer-assisted analysis, statistical frequency can reveal the strength of word-combinations. Sinclair (1991b: 489) has since developed this notion, with "the examination by computer of large collections of texts", to re-assess "the nature and structure of language". Third, the notion of 'unit of meaning' (Sinclair, 1991a: 6-9) can be used to identify the constitution of a multi-word sequence. The unit does not necessarily coincide with grammatical units such as Subject, Verb, Object and Adjunct. Unlike single words, which are often ambiguous, units of meaning express a single meaning (Sinclair, 1991a). The phrase unit can represent the attitude of the speaker/writer, although the

attitude may be occasionally difficult to detect from the individual components of the unit. There are four prominent features of units of meaning: ‘collocation’, ‘colligation’, ‘semantic preference’ and ‘semantic prosody’.

<i>COLLOCATION</i>	the co-occurrence of words
<i>COLLIGATION</i>	the co-occurrence of words with grammatical choices
<i>SEMANTIC PREFERENCE</i>	the co-occurrence of words with semantic choices
<i>SEMANTIC PROSODY</i>	expressing attitudinal and pragmatic meaning.

Table 2.5 Definitions of collocation, colligation, semantic preference and semantic prosody (Sinclair, 2004: 174)

	Semantics		Grammar		Core
PROSODY	difficulty				
PREFERENCE	negative		visibility		
COLLIGATION	<u>adjective</u> <u>modal verb</u>		<u>verb</u> <u>adjective</u>	<u>preposition</u>	
COLLOCATION	small faint weak difficult invisible can/could	...	see visible	with to	
					naked eye

Table 2.6 Lexical description of *naked eye* (adapted from Sinclair, 2003: 151)

The above accounts of units of meaning reveal the fusion of the two polarities: lexis and grammar. Until the hybrid language description of lexis and grammar was established, grammar was described under the conventional rules of language of prescribed grammar, which dictated that a word or phrase could replace anything in a grammatical structure, as long as it fitted the assigned word-class slot: for example, a noun phrase could slot into Subject or Object. Such a ‘slot-and-filler’ model of language accounts for the underlying ‘open-choice principle’ (Sinclair, 1991a: 109). Sinclair finds that many phrases are not, in fact,

accounted for by this model. To give an example, *naked eye* appears to attract other words such as *the* preceding the core words; *with* and *to*, prior to *the*; *see* and *visible* coming before the prepositions (Table 2.6 above). The co-occurring words fall into certain grammatical categories: determiner, preposition, verb and adjective. These words surrounding *naked eye* show particular semantic choices denoting visibility and difficulty. On the basis of phraseological observations, Sinclair judges that the meanings of phrases are attributed to the whole phrase but not to the individual components. The phrase *naked eye* with the words which surround it denotes a particular meaning, that seeing the true nature of something is difficult (Table 2.6 above). This alternative principle underpinning a text of language is defined as the ‘idiom principle’ (ibid.: 110). More importantly, the idiom principle plays an essential part in interpreting a text (Hunston, 2002), because the idiom principle, in general, takes priority over the open-choice principle (Sinclair, 1991a), and does not apply simultaneously (Hunston and Francis, 2000); but if the idiom principle fails to interpret the phrase, then the hearer switches to the open-choice principle (Sinclair, 1991a: 113). The principles each guide “the way in which meaning arises from text” (ibid.: 109). For example, the interpretation of a joke illustrates our use of both the idiom principle and the open-choice principle (Hunston and Francis, 2000: 22-23).

2.6 Lexical priming

Sinclair’s (1991a) analytical approach to lexical items illuminates the co-occurrence of words, namely, collocation. Partington (1998) provides the three definitions of collocation based on text, statistics and psychology¹¹. The textual definition encompasses the relationship of words within a text, as Sinclair (1991a: 170) explains: it is defined as “the occurrence of two or more words within a short space of each other in a text”. Under this definition, the feature of

¹¹ Stubbs (1996; 2002) focuses on the interpretation of collocations, which indicates what may influence language users when establishing them: culture and educational publications, in particular.

collocation is proximity and co-occurrence of words in a text. The statistical definition is that collocation does not occur randomly, but occurs “with greater than random probability in its (textual) context” (Hoey, 1991: 6-7). A psychological definition appears in two versions. The strong version of the psychological definition is that collocation arises from the mind of language users. Partington (1998:16) claims that collocation “is part of a native speaker’s communicative competence”. Stubbs (1996; 2002), in contrast, focuses on the interpretation of collocations, which indicates what may influence language users in establishing them: culture and educational publications, in particular. Note, however, that collocation in a text is first reflected in the mind of language users and afterwards the collocation appears in the use of language. The weak version is that collocation occurs due to what lies beneath the text. It is suggested that collocation represents word association, which is formed by more than randomness: collocation may be a cohesive device (Halliday and Hasan, 1967). This proposition originates from Leech’s ‘collocative meaning’ (1974: 20), indicating that the meaning of the words in collocation leads to the association of the words.

Drawing on the work of the proponents of the psychological definition of collocation, Hoey (2005: 5) interprets the semantic association of collocation by relating their realisation to the psychological associations in speakers’ minds, to which he gives the coinage ‘lexical priming’. Just as words attract collocations, so words are ‘primed’ (in the speaker’s mind) as ‘target’ words in collocations (ibid.,: 8). Hoey also notes that each person’s language experience may be different and her/his own experience may encourage her/him to prime particular words for particular collocations¹². In this respect, priming is a personal phenomenon in psychological processes in language. Yet groups of language users must maintain some homogeneity in language if they are to communicate with each other.

12 It was open to question whether it is the word or the speaker that is primed (Hunston, 2007, personal communication). Hoey (2005: 15) argues that “[w]ords are never primed per se; they are only primed for someone”.

Recalling Stubbs' notion that collocations conform to cultural and educational norms, lexical priming is considered to have an 'external harmonising mechanism' in each community – defined by education, literary and religious tradition and the mass media – to which the language user is particularly exposed (Hoey, 2005: 181-182). Hoey thus accounts for lexical priming being personal, as well as being specific to certain domains and genres (ibid.: 19).

Lexical priming is a concept of lexical behaviour. For Hoey, 'semantic association' encompasses the psychological association of a language user with a word or word sequence (ibid.: 24). The psychological mechanism in lexical choice may account for language creativity, such as Chomskian linguists claim, allowing language users to create new sentences. As long as the words being chosen belong to the same semantic association, infinite variations of sequence can occur: "lexical priming can account for what is natural but also what is possible" in language (ibid.: 17; 153). As regards grammar, Hoey (ibid.: 63; 161) contends that lexical priming and semantic association adopt the same position as pattern grammar (Hunston and Francis 2000): for instance, 'PERSON(S) + BE + *blackmailed/bullied* + *into* + V-ing' which is exemplified in pattern grammar, is considered to be realised by sharing the priming of 'V n *into* n'. Lexical priming and semantic association, as psychological aspects of language, derive, it seems, from the phraseological work of collocation (Sinclair 1991a; 2004), corpus-driven grammar (Francis, 1993) and pattern grammar (Hunston and Francis, 2000).

Investigation into corpora reveals the way in which the different senses of similar words and polysemous words are seen in a particular language environment. The approach of finding distinctive collocations is based on a theory that different collocations and different patterns appear in different senses. First, a corpus study into similar words was given: an account of the different senses in the verbs *BEGIN* and *START* (Biber *et al.*, 1998). The corpus data compiled from fiction and academic prose showed the difference in colligation, which is

the frequent collocation in grammatical choice. Although these verbs are seemingly interchangeable, with *to*-clauses and *ing*-clauses able to follow them, the data show that *BEGIN* is more frequently followed by *to*-clause and is more commonly used as a transitive verb, whereas *START* is more often used as an intransitive verb. In addition, the pattern of *BEGIN* + *to*-clause illustrates a distinctive sense of the verb in academic prose which denotes activities by human or concrete objects, as shown below in (17). This finding suggests that collocation and pattern both shed light on superficially subtle yet essential differences in similar lexical items.

- (17) a. First, one begins to question the need for frequent note regurgitation of words...
- b. Elsewhere, sociologists have begun to disclose the social conditioning of the natural sciences.
- c. The original mass of gas cooled and began to contract.

(Biber *et al.*, 1998: 100, my underlining)

Corpus analysis is also given to describing the different senses of polysemy (Hoey, 2005). *Consequence* is a polysemous word which conveys ‘result’ and ‘importance’ as in (18) and (19) below:

- (18) As a consequence (= result), ethics is the topic in feminist therapy that has been most thoroughly theorized and subjected to questions and debate. (Bank of English)
- (19) Booth’s predicament would have little consequence (= importance) had it not added a further molehill to the mountain of trouble and doubt established before. (Hoey, 2005: 83)

Hoey’s corpus analysis reveals the distinctive features of sense: frequency and collocation. The ‘result’ sense (1640 instances, 90.7%) occurs much more frequently than the ‘importance’

sense (169 instances, 9.3%). The collocations of grammar choice, colligations, characterise the pattern of the different senses in that, first, no *consequence* of the sense was found as Subject, indicating that *consequence* (= importance) is not used as topic. Second, *consequence* (= result) is unlikely to occur with particular deictic, such as *any*, *some* and *no*. Further results of the lexical features of *consequence* in the different senses are shown in Table 2.7 below. As a result, polysemy is highly likely to be accounted for by frequency, collocation and pattern.

	<i>consequence</i> (= result)	<i>consequence</i> (= importance)
Collocation with <i>any</i>	—	+
Collocation with <i>of</i>	—	+
Colligation with subject and complement	Positive	Negative
Semantic association with <i>logic</i>	+	—
Semantic association with <i>negative evaluation</i>	+	—
Semantic association with <i>denial</i>	—	+
Textual colligation with theme	Positive	Negative

Table 2.7 The contrasting collocations, semantic associations, pragmatic associations, colligations and textual colligations of the two uses of *consequence* (Hoey, 2005: 87)

In the light of the results of such analysis, Hoey (2005: 82) proposes the ‘drinking problem’ hypothesis on the nature of polysemy. When you hear the phrase, ‘drinking problem’, it is natural to think about having a problem involving alcoholism. It is unlikely to be associated with a problem with swallowing liquid. If you explain the problem to a doctor, you call it ‘problem drinking’. This hypothesis holds that different collocations and patterns are segmented in accordance with the different senses of a polysemous word:

Where it can be shown that a common sense of a polysemous word is primed to favour certain collocations, semantic associations, and/or colligations, the rarer sense of that word will be primed to avoid those collocations, semantic associations and colligations. The more common use of the word will make use of the collocations, semantic associations and colligations of the rarer word but, proportionally, less

frequently. (Hoey, 2005: 82)

Based on this hypothesis, the lexical features of polysemous *reason*, which means ‘cause’, ‘rationality’ and ‘logic’, were investigated. Suppose that the collocations and colligations of the central sense of *reason* (= cause) are not the same as those of the other senses (= rationality, logic); the different collocations and colligations, and maybe the semantic associations and patterns, too, help us to differentiate the lexical environments of the polysemous word. Hoey (2005) confirmed this hypothesis by deducing the lexical features of *reason* (= rationality, logic) from the more common sense (= cause), resulting in the attestation that *reason* (= rationality, logic) avoids occurring with *the*, pronoun/*there BE reason* structure, being Subject with BE, or occurring in Theme. Therefore, I would argue that collocation and pattern allow us to describe the different meanings of a polysemous word.

In summary, the theory of phraseology is likely to hold that the different senses of polysemy can be described by collocation and pattern. The association between linguistic expression and sense is assumed to originate from psychological priming in language users. However, such a psycholinguistic hypothesis is refuted by Teubert (2010), who claims that sense lies in language, not in the minds of language users.

2.7 Approaches of corpus linguistics to prepositions

Cognitive linguists investigate the senses of prepositions from the supposition that prepositions on their own have an independent meaning, whereas, to my knowledge, few researchers in corpus linguistics have looked for the senses of prepositions alone. It is likely that prepositions are dependent on the other components of a phrase, such as verb, adjective and noun, and that the prepositional phrase conveys meaning. This assumption underpins the concept of ‘core’, “which is invariable and constitutes the evidence of the occurrence of the

item as a whole” (Sinclair, 2004: 141). Moreover, *Collins Cobuild Grammar Patterns 1* (Francis *et al.*, 1996) and 2 (Francis *et al.*, 1998) provide patterns of phrases containing prepositions; however, they focus on the core words as in V *into/over/through*, ADJ *over* n, N *over/into* n and *into* N¹³. Sinclair (1991a) examines the preposition *of* and shows a number of phrases containing the preposition, such as *the kind of...* and *both of...* In his analysis, the preceding noun (N1) and the following noun (N2) are highlighted, rather than the sense of the preposition, and Sinclair suggests that the two types of phrase containing *of* are classified by identifying the headword. The phrases which have the N2 as headword are subcategorised into ‘measure’ (e.g., *a couple of weeks*), ‘focus’ (e.g., *the middle of a sheet*) and ‘support’ (e.g., *the position of France*). In these categories, the N1 offers some of the function of providing additional information to the N2. The other type of *of* phrase has double headwords, which signify that the N1 and N2 have equal status as headwords: titles (e.g., *the Duchess of Bedford*) and nominalizations of the structure of verb-subject or verb-object (e.g., *the British view of the late senator, reflection of light*). In these ways, such a given content word as noun, verb or adjective gives rise to dependency of the preposition on the sense of the phrase. Non-content words (subsidiary words, such as prepositions), are unlikely to contribute to establishing phrase and pattern. As phrase and pattern are closely related to meaning in the theories of corpus linguistics, the weak hypothesis, induced from the theories of phraseology, is that prepositions are unlikely to be the principal elements in conveying the sense of the prepositional phrase. The strong version, rather, is likely to be that prepositions have no meaning and only contribute to emphasising an aspect of the co-occurring content words, as shown above in the examples of *of* phrases.

Is it unlikely that prepositions take an integral part of the phrase and contribute to

¹³ The upper case of V, ADJ and N represents the core of the phrase. V stands for verb, adj for adjective and n for noun (Francis *et al.*, 1996; 1998).

conveying the meaning of the phrase? It is not impossible that the preposition has a semantic association and attracts certain collocates to formulate a prepositional phrase. Kennedy (1991) attempts to describe the different senses of prepositions *between* and *through*. He extracted from the LOB (Lancaster-Oslo/Bergen) corpus the words which occur before and after the prepositions. The result indicates that nouns and pronouns frequently precede *between* (65.7% of tokens) and verbs often come before *through* (43.2%). In many cases numbers follow *between* (34.0%) and the prepositional phrase containing *through* tends to occur at the clause final (32.3%). Moreover, particular senses of the prepositions were found with particular collocations of noun and verb. His conclusion is that collocation, in this case the particular preceding nouns and verbs and the following phrases, can differentiate the language behaviour and senses of the prepositions. Based on this, I would argue that the semantic association of collocation is likely to be a two-way attraction between words, as opposed to a unidirectional attraction from such 'core' words as verb, adjective and noun to preposition. It still remains in dispute whether the preposition in the phrase has a meaning or not. Moreover, as Sinclair (1991: 111) remarks, "many phrases have an indeterminate extent": the boundary of the phrase which denotes meaning is fuzzy. To what extent does a preposition contribute to the meaning of the phrase and the clause?

In corpus linguistics, phrasal verbs have been investigated as the main subject of the collocations related to prepositions. As the proper use of phrasal verbs is difficult for learners of English to master, the overuse and underuse of phrasal verbs is investigated by employing a learner corpus (Nesselhauf, 2005). The *Collins Cobuild Dictionary of Phrasal Verbs* (Sinclair *et al.*, 2002), which is based on an analysis of a corpus of enormous size, the Bank of English, providing a particle index of phrasal verbs. The index categorises the senses of phrasal verbs according to the embedded particle. For example, the index of *over* lists as many as seven senses (ibid. : 41-43 in appendix): 'movement and position' (e.g., *GO over*), 'overflowing and

overwhelming feelings' (e.g., *BOIL over*), 'falling and attacking' (e.g., *FALL over*), 'covering and hiding' (e.g., *GLOSS over*), 'considering and communicating' (e.g., *RUN over*), 'changing and transferring' (e.g., *HAND over*) and 'ending and recovering' (e.g., *GET over*). Despite the elaborate classification, it is surprising that most of the senses overlap the senses of *over* proposed by Tyler and Evans (2003a, see Chapter 6). If the sense of phrasal verb could be categorized by the particle, the particle would contribute much to the sense, whereas the verb might do little. This appears to contradict the supposition above, that the preposition is a dependent element of the phrase as opposed to verb, adjective and noun. I would argue that the incorporated particle of the phrasal verb, such as the preposition or adverb after the verb, is involved in establishing the meaning. The preposition in the phrasal verb does contribute to the meaning.

Again, it should be noted that in the semantic association, the preposition and other words are attracted each other. The study conducted by Gardner and Davies (2007) supports my hypothesis. They quantify frequent phrasal verbs in the British National Corpus and demonstrate that the top 20 lexical verbs, such as *GO*, *COME*, *TAKE* and the like, occur frequently with some of 16 particles, such as *over*, *through*, *out*, *up*, *on*, etc. The results indicate that the combinations of verbs and particles are not uniformly frequent. Particular combinations are frequently found: for example, *COME over*, *TAKE over*, *GET through*, *GO through*. The uneven attraction between the verb and particle of phrasal verbs suggests that collocation is determined for some reason. Corpus analysis is expected to reveal the contributing factor of collocation behind the text.

Collins Cobuild Grammar Patterns 1 (Francis *et al.* 1996) and *2* (Francis *et al.* 1998) classify the patterns containing prepositions. Prepositions are not the core of classification, as in ADJ *over* n, N *over/into* n and *into* N; however, the patterns are classified according to different prepositions, such as V *into* n, V *over* n and V *through* n. This implies that the senses

of the pattern can be differentiated by the embedded preposition. In other words, it is certain that the sense of V *into* n differs from that of V *over* n, since the difference between *into* and *over* to a certain extent relates to the semantic difference between the patterns V *into* and V *over*. Hence, prepositions are not irrelevant to the sense of pattern. In the same manner as that involving the verb, adjective and noun, the preposition is an element in the sense of pattern, although it is not clear how far the preposition gets involved in the sense. The patterns of N *into* n and *into* N indicate the different core words of the patterns. N *into* n represents the N1, the capitalised N, as the core of the semantic association of the pattern, whereas *into* N is composed by the core N2, which follows the preposition. N *into* n contains of two nouns which function in the relationship of verb-subject (cf. Sinclair, 1991a), as in *their entrance into the war, their incursion into the exclusion zone and the inquest into the deaths of two firefighters* (Francis *et al.*, 1998: 174, my underlining). By contrast, *into* N does not necessitate the co-occurrence of the noun preceding the preposition, because the phrase tends to follow the verb as in *There's now a real danger that the country will slip into anarchy* (Francis *et al.*, 1998: 304, my underlining). The studies on collocation related to prepositions suggest that verb, adjective, noun preceding preposition and following noun co-occur with preposition. Put another way, these words have a semantic association with the preposition, as illustrated in Figure 2.18 below. Given that collocation differentiates the senses of polysemous words, prepositions, which have different senses in a single orthographic form, can be distinguished by the relation of the co-occurring nouns, verb and adjective. My methodology in this study is applied to the method in order to explain how the preceding and following nouns, and also the verb, are associated with different senses of prepositions.

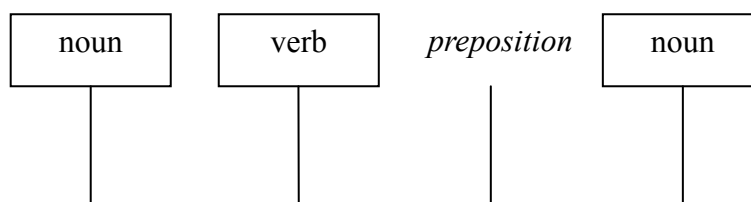

Figure 2.18 Semantic associations of collocation with preposition

2.8 Meaning and lexical representation

The question about what determines meaning, which widely varies according to the context, has been challenged by cognitive linguists and corpus linguists. As has been seen in the previous sections, their approaches differ in that mind, embodied experiences and encyclopaedic knowledge of language users are considered to relate to meaning in cognitive linguistics, whereas it is assumed in corpus linguistics that combinations of words and phrases produced by language users represent meaning construction. Although the theoretical backgrounds are distinct, namely claiming that meaning is determined by language users or language itself, there is one common point at which the key factor of meaning construction is agreed: that is, ‘collocation’. It is a principal argument of corpus linguistics that develops by focusing on tendencies of co-occurrence of words. Cognitive linguists claim that such “selectional tendencies in terms of collocational patterns” (Evans, 2009: 67) indicate the way in which we use lexical representation which relates to conceptual structure of meaning. As some corpus linguists argue (e.g., Hoey, 2005), collocation can represent our psychological processing of meaning construction.

‘LCCM Theory’ (lexical concept and cognitive model theory), suggested by Evans (2009), holds that language does not directly relate to meaning, but rather that two facets interrelate in meaning construction by language: ‘lexical representation’ and ‘semantic composition’. Evans argues that language is composed in order to encode highly conceptual

information and facilitates access to non-linguistic content which is insufficiently indicated by the lexical representation. In other words, language, which is represented by words, morphemes, idiomatic phrases and grammatical construction, is only a vehicle that triggers a conventionalised way of interpretation of meaning. Language is not directly associated with meaning; lexical representation, which works under the rules of language, and semantic composition, which relates to non-linguistic information, complement each other for interpretation of meaning.

Before the development of LCCM theory, it was assumed that language was the representation of a stable meaning (Brugman and Lakoff, 1988; Lakoff, 1987) and that meaning could be completely decoded only by language. In addition, polysemy was considered to have different senses associated with a phonological form (vehicle) and stored in the mental lexicon of language users. Such full specification interpretation (Lakoff, 1987: 422) excludes the involvement of entities concerned in the context and flexibility of meaning. Opposed to the obsolete approach to meaning, LCCM Theory concerns a subtle context-dependent meaning which varies according to the entities involved in the configuration. Therefore, noun collocates, which indicate the entities involved, should be analysed to investigate interpretation of meaning. In this section, I present how LCCM Theory is compatible with the theory of ‘phraseology’ which suggests the relationship between lexical representation and meaning.

2.8.1 Lexical representation and semantic composition

In the classic approach to meaning in cognitive linguistics, lexical representation was considered to express semantic composition which leads to interpretation of meaning. In LCCM Theory (Evans, 2009), these processes of language and meaning are clearly differentiated. As shown in Figure 2.19 below, LCCM Theory consists of ‘lexical

representation’ and ‘semantic composition’. Lexical representation is divided into symbolic units and cognitive models. Symbolic units are composed of phonological forms and lexical concepts. In the classic approach, phonological form and lexical concepts were assumed to be identical. In other words, language was thought to express meaning. The research on polysemy of prepositions in particular (e.g., Brugman and Lakoff, 1988; Lakoff, 1987) showed that a phonological form, such as *over*, could convey more than one sense. In contrast, LCCM Theory argues that language is unlikely to represent meaning in a straightforward way. Lexical representation is not directly linked with semantic composition; lexical concepts related to cognitive models are associated through lexical representation with semantic composition in which non-linguistic information is involved.

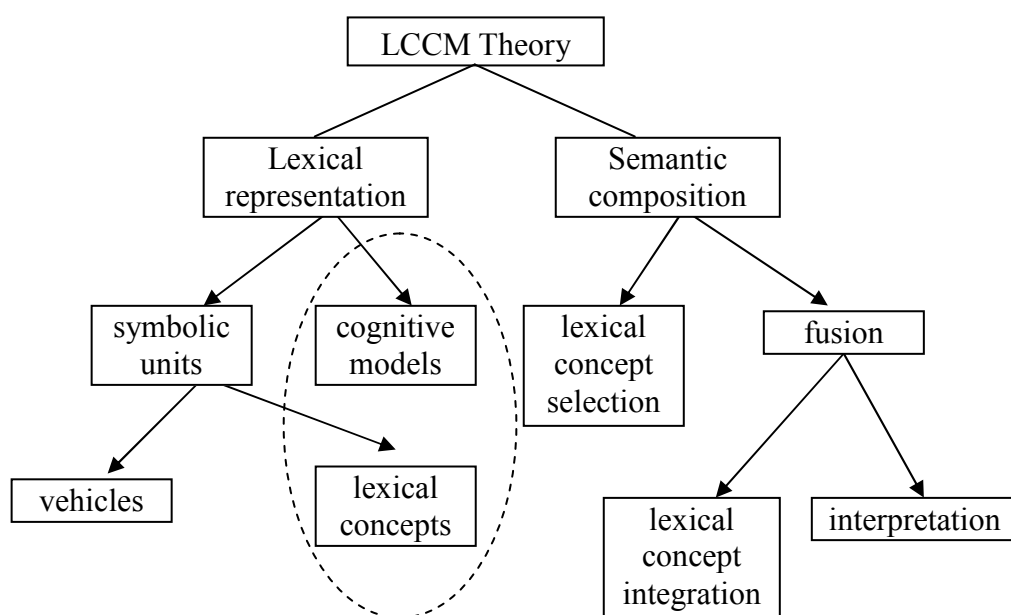

Figure 2.19 Architecture of LCCM Theory (Evans, 2009: 75)

LCCM Theory is not the first time that the segregation of lexical representation and semantic composition has been argued. Before the development of this theory, some researchers had already implied that lexical representation is not fixed and does not precisely

correspond to semantic composition (e.g., Allwood, 2003; Croft and Cruse, 2004; Evans, 2009; Taylor, 2003; Zlatev, 2003). Rather, lexical representation is flexible so that a creative, unconventional use of words can be realised. Take *John baked Mary a cake* for example. Unlike *GIVE* and *send*, *BAKE* is not used as a ditransitive construction verb, which has two object nouns: recipient and thing. However, the semantic composition of ‘X INTENDS Y TO RECEIVE Z’ makes it possible that *BAKE* can co-occur with the recipient noun and thing noun. Goldberg (1995, 2006) coins this form-meaning relationship as ‘Cognitive Construction Grammar’. To put it another way, it can be argued that the form of *John baked Mary a cake* has the underlining meaning of X INTENDS Y TO RECEIVE Z and the lexical representation carries “meaning independently of the words in the sentence” (Goldberg, 1995: 1). It follows that theories of corpus linguistics, such as ‘semantic prosody’ (Sinclair, 2003), which holds that meaning is conveyed by phrase, and ‘pattern grammar’ (Hunston and Francis, 2000), which suggests that meaning can be specified by collocation patterns, can be compatible with Cognitive Construction Grammar.

Moreover, Evans (2009: 36) argues that “grammar is no longer viewed as constituting an abstract set of rules which operates word. Rather, the lexicon and grammar form a continuum, each consisting of bipolar symbolic units comprising a form and meaning: ... known as the lexicon-grammar continuum”. Semantics and syntax are not considered to be separated in corpus linguistics, too; rather, they interrelate to determine the use of words and grammar form, which is called ‘lexico-grammar’ (Francis, 1993). The example of *BAKE* also indicates the English ditransitive verb of X INTENDS Y TO RECEIVE Z: for example, the subject role must be filled with a volitional agent who intends transfer (Goldberg, 1995). Such selectional tendencies of words are also suggested in corpus linguistics, such as collocation, typical co-occurrence of words, and colligation, grammatical preference in word selection. In conclusion, in both cognitive linguistics and corpus linguistics segregation of lexical

representation and semantic composition is agreed and collocation is the key factor to reveal form and meaning relationships in terms of meaning construction. Note that, although corpus linguists are unlikely to imply this overtly, cognitive linguists hypothesise that lexical representation functions to prompt a particular meaning which is unable to interpret only linguistic information.

2.8.2 LCCM Theory concerning polysemy

LCCM Theory (the theory of lexical concept and cognitive models; Evans, 2009) suggests that semantic structure and conceptual structure are established at distinct levels and lexical concepts encoded by the phonological form provide access to cognitive models which contain non-linguistic conceptual knowledge. LCCM Theory has made two substantial contributions to the research of meaning construction: segregation between lexical representation and semantic composition, and restriction of the function of lexical representation in meaning interpretation.

Unlike Cognitive Grammar, proposed by Langacker (1987), which holds that lexical representation incorporates the nuances of encyclopaedic knowledge, an independent yet corresponding lexical representation is hypothesised to help us to interpret meaning owing to our encyclopaedic knowledge induced from context. As a result, Evans (2009) notes that it is important to analyse how far lexical representation contributes to semantic composition of meaning by virtue of agreement between the lexical concept and cognitive model. Yet, few empirical analyses of the relationship between lexical representation and semantic composition have been so far carried out. This study, which investigated more than one thousand instances of lexical representation, is likely to demonstrate the contribution of lexical representation and encyclopaedic knowledge to interpreting meaning.

Before the advent of LCCM Theory, the contribution of lexical representation, which

is known as ‘linguistic prompt’ (Fauconnier and Turner, 1998), to meaning-construction processes had already been discussed. However, the focus of the analysis was on the conceptual system of language users; it was not concerned with lexical representation related to meaning. Langacker’s Cognitive Grammar (2008) as well as Croft and Cruse’s approach (2004), on the other hand, takes into account the contribution of lexical representation, but in the theory lexical representation is thought to accurately represent our process of interpretation including the information concerning encyclopaedic knowledge, which is difficult to encode in lexical representation. As discussed above, Goldberg (1995, 2006) suggests that meaning is not limitedly conveyed by lexical representation: lexical concept which derives from meaning can be reflected in lexical representation. Her theory of ‘Cognitive Construction Grammar’ adopts the same position as LCCM Theory, that lexical representation is somehow associated with meaning. In contrast, LCCM Theory suggests that lexical representation prompts processes of semantic composition and gives access to non-linguistic encyclopaedic knowledge which is necessary for a reasonable interpretation of meaning. In addition, it is suggested in LCCM Theory that lexical representation and sense do not necessarily exist in a one-to-one relationship; rather, a single phonological form can be conventionally associated with more than one sense. Such one-to-many relationships between form and meaning are found in polysemy.

Collocation is the key element of ‘selectional tendencies’ which demonstrate processes of prompting meaning construction (Evans, 2009: 67). This proposition agrees with Hoey’s ‘lexical priming’ (2005) which is applied to differentiate a polysemous word by looking at its collocation. In LCCM Theory, polysemy is hypothesised to be a linguistic phenomenon in which a single lexical representation is associated with a number of lexical concepts framed thorough processes of semantic composition. Unlike LCCM Theory, preceding studies concerning polysemy in cognitive linguistics were less concerned with

lexical representation. Polysemy was assumed to emerge from a single abstract mental representation which underlies the mental lexicon of language users (Brugman and Lakoff, 1988; Lakoff, 1987). After the theory of meaning independent of context, interaction with linguistic environment, such as collocation and grammatical construction, was considered to mediate semantic composition (Allwood, 2003; Croft and Cruse, 2004; Zlatev, 2003). In the light of the new approach, LCCM Theory evolves the hypothesis, in that a single lexical representation is associated with different semantic concepts which mutually relate to a greater or lesser extent.

LCCM Theory sheds light on a new approach to meaning construction which indicates lexical representation functions to prompt the access to meaning interpretation, and suggests that collocation represents semiotic processes of meaning construction. As suggested by the proposer of the theory (Evans, 2009), it can be adopted to investigate the form and meaning relationship of prepositions which have polysemous senses under a single phonological form. Little empirical research into the relationship, however, has been so far carried out. My research, by analysing corpus data, explores how far the lexical representations of prepositional phrases correspond to the senses of prepositions.

2.9 Summary of the chapter

This chapter has been devoted to discussing how the spatial and non-spatial senses of prepositions have been investigated by means of the approaches of cognitive linguistics. The central theses of cognitive linguistics are embodiment and prototype, which provide the rationales for the structuring of the semantic network of prepositions. The prototype of prepositions is likely to be determined by physiological factors, the referential, the statistical and the psychological (Geeraerts, 2007). It can thus be argued that these factors result from the effects of embodiment and construal. The prepositional sense is decomposed into two

constituents: the trajector (TR) is highlighted and the landmark (LM) is backgrounded. Image schemas are actively involved in the establishment of the locative sense, as well as the metaphorical ones. As some experiments demonstrate, not only the spatial sense but also the non-spatial is likely to occur in accordance with particular types of verb, TR and LM. In the next chapter we explore the way in which another linguistic approach, corpus linguistics, attempts to describe the senses of prepositions.

I also have explored in this chapter the feasibility of using corpus analysis in describing polysemous prepositions. Corpora are data which represent the language used in practice, as opposed to artificial data invented by armchair linguists. Corpus analysis attempts to describe the features of language which have not been found by conventional linguistics methods, resulting in the development of new concepts, such as units of meaning and the idiom principle. The new approach reveals that collocation is closely related to the meanings of phrases. As for prepositions, particular nouns and verbs frequently occur with particular prepositions. Moreover, it is likely that semantic association is observed in particular senses of polysemous prepositions. However, even though corpora are powerful tool for language investigation, it is not clear what gives rise to collocation. It remains an open question whether collocation depends on the individual knowledge of each language user or on society. However, I would argue that the semantic association between words makes it easier to find the linguistic environment of different senses of prepositions, regardless of our basic uncertainty over what associates words which are said to be collocated.

3. DATA AND METHODOLOGY

My hypothesis is that the senses of prepositions can be predicted by the nature of the noun phrases indicating the trajector (TR) and the landmark (LM). The TR and the LM are considered to be the elements by which the spatial relationship of prepositions can be established (Langacker, 1987). To my knowledge, few researchers investigating the senses of prepositions have used corpus data. In other words, descriptions of the senses of prepositions tend to rely on the intuitive knowledge of the researchers. As a non-English speaker, I would not wish to resort to my intuition. Corpora are an invaluable tool to represent the use of language by native English-speakers objectively¹.

Moreover, the machine-readable data facilitate further insights into language, particularly concerning frequency and connections between words. The frequency of words and phrases suggests the level of typicality in language. As regards the senses of prepositions, it has been suggested that a frequent sense can be a possible prototype if the statistical hypothesis is considered to be plausible (Geeraerts, 2007: 168, see section 2.2.1). Statistical scores based on frequency, such as T-scores and MI scores, indicate which words frequently co-occur. A string of co-occurring words can suggest a pattern composed of the words. The theory which allows me to propose my hypothesis on prepositions and their collocations is that different collocations denote different senses of polysemous words (e.g., Hoey, 2005: 87). That is to say, different senses of prepositions can be predicted by their collocations and pattern. Based on this hypothesis, I carried out corpus research into the collocations and patterns co-occurring with prepositions in order to identify their senses.

¹ The representativeness of data should be borne in mind when corpora are investigated (Hunston, 2002). The language data should be collected from the appropriate target language users. This study aims to explore how English speakers use the different senses of prepositions in relation to the collocations of the TR and the LM. The ICE GB corpus is therefore a proper source of data to represent their language use.

3.1 Corpus data

The corpus data of this study is the ICE GB corpus (the British component of the International Corpus of English), which was compiled by University College, London. The corpus, at one million words, is not as large as the reference corpora which aim to represent a wide variety of language: for example, the Bank of English (<http://www.titania.bham.ac.uk/docs/svenguide.html>) contains 450 million words and the BNC (British National Corpus, <http://corpora.lancs.ac.uk/BNCweb/home.html>) has 100 million words. Despite its relatively small size, the corpus design of the ICE GB is so organised that 500 texts of about 2000 words each cover a broad range of spoken and written uses of language: the sub corpora of the spoken texts are dialogues, monologues and mixed, whereas those of the written texts are non-professional writing, correspondence, academic writing, non-academic writing, reportage, instructional writing, persuasive writing and creative writing (<http://www.ucl.ac.uk/english-usage/projects/ice-gb/design.htm>). With such a variety of language uses, therefore, lack of representativeness is unlikely to be a problem.

The advantage of the ICE GB corpus is that the texts are parsed and annotated with part-of-speech tags into 20 word classes, and with grammatical tags with more than 90 indicators of function and category. These tags allowed me to retrieve the prepositional phrases containing *over*, *into* and *through* which co-occur with the trajector noun and the landmark noun. The string search of clauses containing a verb and prepositions makes it easier to extract the phrases from the corpus. While the landmarks of prepositions tend to be found in the noun phrases which follow them, the trajectors can be found in either the noun phrase as subject, as in example (1) below, or the noun phrase as object directly after the verb, as in (2) below. I carried out another string search of clauses containing a verb followed by an object noun phrase and the prepositions. This led to the extraction of the instances where the trajector followed the verb.

- (1) A mist hung over the river. <W2F-013 #071>
- (2) ‘Friday’s announcement about Ravenscraig had cast an immediate shadow over the jobs at the terminal’, he said. <W2F-015 #022>

	① V prep	② V O prep	①+②	TR LM combination
<i>over</i>	382	98	480	402
<i>into</i>	647	83	730	648
<i>through</i>	381	75	456	316

Table 3.1 Instances of V prep and V O prep retrieval from the ICE GB

Table 3.1 shows the number of instances that retrieved the strings of ‘verb + *over/into/through*’ and ‘verb + object noun phrase + *over/into/through*’. In general, the instances of the V prep structure appear to outnumber those of the V O prep. As the aim of this study is to examine the relationship between the senses of the prepositions and the collocations of the trajector noun and the landmark noun, all instances missing either the trajector or the landmark were excluded from the research data. Specifically, examples (3) and (4) below illustrate adverbial *over* and *through*, which occur without the LM. The LMs can be inferred from the context referring to earth and ground in relation to the explicit trajectors. As for *into*, although its adverbial use was hardly ever found, there were many duplicate instances referring to the same phrase in the data; they were manually removed from the data set. In addition, the instances with an uncertain TR and LM were not examined for the purpose of classifying the TR and the LM.

- (3) It was completely frozen over. <S1A-014 #205>
- (4) The ball goes through to David Ripley, for no run. <S2A-013 #077>

3.2 HCA classification

402 instances of phrases containing *over*, 648 instances of *into*, and 316 instances of *through* were examined in order to test my hypothesis that particular collocations of the TR and the LM co-occur in one particular sense of the prepositions. Their TR and LM nouns were manually classified into human beings (H), concrete objects (C) or abstract objects (A) and I examined whether there is a relationship between the combinations of the nouns and the sense of the prepositions. The frequencies of the different combinations of the TR and the LM, such as HH (human TR and human LM); HC (human TR and concrete object LM); HA (human TR and abstract object LM); CH (concrete object TR and human LM); CC (concrete object TR and concrete object LM); CA (concrete object TR and abstract object LM), AH (abstract object TR and human LM); AC (abstract object TR and concrete object LM); and AA (abstract object TR and abstract object LM), were statistically tested in order to find overused and underused combinations.

To classify the TR and the LM, I adopted the HCA classification due to my hypothesis that our construal of the world relates to the way in which we determine the senses of polysemous prepositions. If this is the case, it follows that the TR and the LM may be classified into categories which are reflected by our construal. Schönefeld (2006: 307) uses five categories to classify the trajector in relation to the posture verbs of English, German and Russian. Schönefeld's results suggest that the equivalent verbs in the different languages have distinctive collocations for the trajector. The categories of the trajector are human beings, concrete objects, abstract objects, personified objects and animals.

- (5) ...and **FOR SALE signs** hanging dispiritedly over **sagging wooden doors**.
(TR) (LM)

<W2F-006 #025>

In this study, I restricted the categories in terms of the TR and the LM nouns to three: human beings (H), concrete objects (C) and abstract objects (A). As language users associate the senses of posture verbs with embodied experiences, recurrent experiences of the spatial configuration of prepositions may relate to the mental representations among language users (Beitel *et al.*, 1997, Gibbs *et al.*, 1994). The trajector is the focused entity in the spatial configuration of prepositions, while the landmark is the background (see section 2.2.3, above). As in (5) above, the subject or the agent, ‘*FOR SALE signs*’, is the trajector, while the noun phrase after the preposition, ‘*sagging wooden doors*’ is the landmark. The first reason for reducing the categories to three is that Schönefeld’s five categories (2006: 307) lead to as many as 25 (five by five) combinations of the TR and the LM. Having too many combinations is likely to lessen the frequency of each combination. Low frequencies may make it difficult to statistically test the differences in the frequency of the HCA combinations. The three categories of the HCA narrow it down to nine combinations of TR and LM as illustrated in Table 3.2 below.

		LM		
		H	C	A
TR	H	HH	HC	HA
	C	CH	CC	CA
	A	AH	AC	AA

Table 3.2 HCA combinations of the TR and the LM

The second reason is that members of Schönefeld’s category of personified objects can be categorised into one of the HCA categories. One of the purposes of this study is to describe metaphorical extensions of prepositional senses. Metaphors are expressions which highlight an aspect of a concrete object and map it onto an abstract object (cf. Lakoff and Johnson,

1980). The TR of example (6) below, *a final eye*, does not literally refer to the concrete object's 'visual organs', but to the abstract object 'glance', which is metonymically highlighted, since the word co-occurs with the examine sense of *over* (see section 2.4). Personified objects also exhibit such metonymical highlighting of the TR and the LM, as in (7) below; *the United Nations* is specified by the context as the people working for the organisation. Such 'intentional objects', in which entities are motivated in their actions by human desire, are classified as members of the human category (Anscombe, 2002). The interpretation of the metonymy of the TR and the LM depends on the context. In other words, collocations which suggest their context are likely to determine the interpretation of personification.

- (6) I do not think I have changed the meaning at all, but perhaps it would be as well for <unclear-word> to cast a final eye over it anyway. <W2A-030 #008>
- (7) He said the United Nations had no control over the military action. <S1B-027 #113>

3.2.1 Experiment on the HCA classification

15 postgraduates of English Department of the University of Birmingham were asked to classify the 18 instances of the ICE GB corpus (Table 3.3 below)², which I found difficult to classify into one of the HCA categories. The first languages of the participants were diverse: three English-speakers, one Romanian, one Serbian/Croatian, two Japanese and eight Chinese. It is possible that the classification of instances by those who speak English as a second language may differ from that made by native speakers. However, this experiment is worthwhile, since it shows how the HCA classification is performed. Note that no strict criteria of classification were given to the participants; they classified the instances according

² The Serbian/Croatian postgraduate did not answer questions (5) and (12) and the Japanese postgraduate did not answer questions (3), (9) and (18). Therefore, the number of answers to the five questions is 14.

to their intuition.

Table 3.3 shows that the results can be divided into four types of cases: 1) cases where most of the participants agreed with the category; 2) cases where a questioned entity was somewhat evenly classified into H, C or A; 3) cases where it was classified into H or A; and 4) cases where it was classified into C or A. As for the most agreed classification, the cut-off point of broad agreement was 70 per cent. In other words, if more than 70 per cent of the participants agreed, the classification is assumed to be by general consent. For example, *nerve injuries* of Q10, *the shot* of Q12, *the world* of Q17 and *the coalition* of Q18 were mostly classified as abstract objects (A). These results seem to suggest that intangible objects tend to fall into the category of abstract objects. As in (8) below, *the shot* of Q12 refers to the action of smacking a ball according to the context, not to any such concrete object as a ball itself.

- (8) Q12: Again, power is obtained by transferring the weight forwards, so try to step into the shot. <W2D-013 #084>
- (9) Q16: Just to run through the batsmen who scored the runs Taylor four Benson forty-three Hinks twenty-five in only twenty one twenty-one balls Graham Cowdrey fifteen Nigel Long five Matthew Fleming that delightful fifty-one Steve Marsh six. <S2A-013 #041>
- (10) Q15: We'll run through the Arsenal line-up. <S2A-018 #017>

Metonymy seems to be the main concern for the classification. While *the batsmen* of Q16 were largely classified into human (80%), in a similar context the classification of *the Arsenal line-up* of Q15 was divided into three: three (20%) chose H, six (40%) chose C and six (40%) chose A. Both words metonymically refer to the list of players, not to people; however, the participants were likely to be affected by the literal meaning of *the batsmen*, resulting in their being classed as belonging to the human category. Such evenly classified

entities make explicit the problem of classifications where metonymy is involved. The classification of *[t]hird World countries* and *the United Nations*, as in (11) and (12) respectively, was disputed, in that more than half of the judgements inclined to abstract objects, whereas some considered them to be human or concrete objects. This is because *[t]hird World countries* and *the United Nations* metonymically refer to those who organise and control them. The classification of either H or A, as in (13), also depicts an effect of metonymy. Technically, the Faculty of Arts is an organisation in a university, but it is obvious in this context that the phrase refers to the group of people who work in it. Metonymy should be taken into consideration when implementing the HCA classification.

- (11) Q5: ... **Third World countries** and which have displayed rapid economic and industrial growth over the past three to four decades. <W1B-013 #003>
- (12) Q6: He said **the United Nations** had no control over the military action. <S1B-027 #113>
- (13) Q2: ... she just appointed people she knew who were active in the union and who came into **the faculty of arts**,... <S1B-075 #079>

Metonymy also appears to be involved in the classification of either C or A. Some of the participants identified the entities of questions 7 and 9 as referring to a concrete object, in accordance with the literal sense (Q7: five answers and Q9: eight in Table 3.3), whereas others saw the entities in question as referring to an abstract object (Q7: nine answers and Q9: six). If, on the one hand, the place of *the final bend* is highlighted in the construal of the participants, it is construed as a concrete object. If, on the other hand, the action of running into the corner is highlighted, it is construed as an abstract object. It is therefore obvious that metonymy is involved in the classification of HCA; however, it is probably difficult to make a definitive judgement as to which category to choose. This is because cognitive categories are fuzzy, not clear-cut, and overlapping between categories can occur (Ungerer and Schmid,

2006).

- (14) Q7: And they lead to forces acting on the structural elements which are usually then distributed through the height of the building. <S2A-025 #029>
- (15) Q9: As they come into the final bend now it's going to be Chris Louis who takes the chequered flag. <S2A-012 #084>

Given that the boundaries of the HCA categories are fuzzy, objective criteria for the HCA classification should be given, for the purpose of clarifying the research. Based on the findings from the experiment, I propose the following criteria for HCA classification:

human (H): animate entities, such as human beings and animals, are categorised into this category. Intentional objects, such as groups and organisations, also fall into this. e.g., *people, population, monkeys, company, the United Nations, powerless minorities*

concrete objects (C): tangible objects are categorised into this category. Metonymy is taken into consideration when referring to action and concept, although the literal sense of the word indicates a concrete object. e.g., *vehicle, light, station, area, the Atlantic, New York*

abstract object (A): intangible objects. The words of concrete objects metonymically refer to the action and the concept in which the concrete object is involved. Such cases fall into the category of abstract objects. e.g., *troubles, agreement, believing, period, year, fashion, power*

In order to decode the metonymic reference of the TR and the LM, the context should be examined by reading the preceding and following lines, as well as the whole concordance line itself. I manually performed the HCA classification according to the context in which the TR and the LM appear. In the following section I outline my hypothesis regarding the HCA combinations of the TR and the LM.

3.2.2 Metaphorical extension of the HCA combinations

The aim of this study is to provide an account of the preposition senses in relation to the noun

phrases realising the TR and LM. The HCA classification can describe different senses of the preposition according to combination, on the cognitive linguistic grounds that our embodied experiences are reflected in language. For this reason, it is assumed that the basic conception of prepositions is formulated through physical experiences. For example, the basic concept of *into*, penetration, is highly likely to be experienced by a scene where a concrete object enters another concrete object. Not only the concept of *into*, but also that of other prepositions which denote locative sense, emerges from the relationship of physical entities, since the spatial cognition which we primitively acquire from an early age is argued to give rise to the conceptualisation of language (Lakoff and Johnson, 1980). I would hypothesise that the combination of concrete objects, i.e., concrete object TR and concrete object LM (CC), will be the configuration mostly seen with the prepositions denoting the central sense (Table 3.4 below).

		LM		
		H	C	A
TR	H	HH	HC	HA
	C	CH	CC	CA
	A	AH	AC	AA

Table 3.4 CC combination as the central sense

Secondly, the sense which has the second highest level of frequency involving a concrete object may be called the first peripheral sense. This is partly because the involvement of a human being as either TR or LM, when the focal point of the scene lies on the inside of the TR or LM, may be less objectively observed than the CC combination. A human TR and a concrete object LM (HC), and a concrete object TR and a human LM (CH) would be seen with a preposition denoting the first peripheral senses from the central sense

(Table 3.5 below).

		LM		
		H	C	A
TR	H	HH	HC	HA
	C	CH	CC	CA
	A	AH	AC	AA

Table 3.5 HC and CH combinations as peripheral senses

Thirdly, a human TR and a human LM may be the last configuration which we can experience bodily, although admittedly the situation where someone speaks of entering someone else is relatively rare and somewhat specialised. However, physical entities which we can see in the world tend to be more frequently experienced than abstract ones. Therefore, the HH combination is hypothesised to co-occur with the second peripheral sense of the preposition (Table 3.6 below).

		LM		
		H	C	A
TR	H	HH	HC	HA
	C	CH	CC	CA
	A	AH	AC	AA

Table 3.6 HH combination as a peripheral sense

Finally, the combinations involved in an abstract object are categorised as ones relevant to figurative senses, on the cognitive linguistic grounds that figurative senses are considered to come into play as a result of the conceptual projection of a physical configuration onto a metaphoric domain (Evans, 2007a). For instance, in *But, will Mason's*

probable superior power come *into play* and wear him down late on <S2A-009 #103>, the configuration of *power* into *play* is probably analogous to a path movement in which an entity shifts to the other side. Thus, the combination containing an abstract object is relevant to figurative senses which derive from a physical configuration.

		LM		
		H	C	A
TR	H	HH	HC	HA
	C	CH	CC	CA
	A	AH	AC	AA

Table 3.7 Combinations containing an abstract object as peripheral senses

It could, as a consequence, be hypothesised that the HCA combination of the TR and LM relate to the central sense and the peripheral senses as shown in Table 3.8 below. The table indicates that the CC combination (1) may closely relate to the central sense of *into*, and the other combinations may be relevant to the peripheral senses in the order of the numbers (2 to 9) from configurations which can be experienced physically all the way to abstract ones. The relation of the HCA combinations to the central sense forms a ‘radial category’, suggested as a theoretical structure of a semantic network (Lakoff, 1987, cf. 2.1 Categorisation).

		LM		
		H	C	A
TR	H	4	2	5
	C	3	1	6
	A	7	8	9

Table 3.8 HCA combinations in the order of the central to peripheral senses

The HCA combinations were employed to examine the relationships of the form of the phrase containing the preposition, the TR and the LM and the senses of prepositions *over*, *into* and *through*. The form of the phrases was detailed, describing the pattern containing the verb. If the HCA combinations could correspond to the senses of the prepositions, a semantic network of prepositions based on the collocations could be established which would be unlike a conventional semantic network based on the similarities of the senses as judged by the intuition of researchers. The analyses of the semantic networks of the prepositions are explained in detail in the following chapters.

3.3 Prototypicality of the senses of prepositions

In the previous section, we have seen the phases in the combination of the TR and LM of the preposition-centred phrase from CC (concrete object TR and concrete object LM) to AA (abstract object TR and abstract object LM). My hypothesis is that there is a relationship between the senses of prepositions and the combination of their TR and LM. In order to find the correlation, various senses of prepositions ought to be arranged in the order of prototypicality, which represents that the locative sense is highly likely prototypical whereas the metaphorical sense is less prototypical.

Some textbooks, dictionaries and linguistic studies suggest the prototypicality of the

senses of prepositions. For example, a textbook for EFL (English as Foreign Language) learners, *English Grammar in Use* (Murphy, 2004: 246), introduces the locative sense of prepositions into understanding their diverse senses, as in *at the bus stop*, *on the table* and *in the room*. Similarly, a dictionary for learners of English, *Collins COBUILD Advanced Learner's English Dictionary*, starts the entries of the 25 different senses of *over* with the position and movement sense (Sinclair *et al.*, 2003: 1022). If language teachers provide learners with information about metaphor and semantic extension, the learners can develop their learning strategy (Littlemore and Low, 2006). As for linguistic research, the locative sense, which is suggested as 'proto-scene' by Tyler and Evans (2003a: 50), is situated as the centre of the semantic network of *over*. The arrangement in the diagram implies that the locative sense is prototypical and the other senses in periphery are less prototypical. It can be concluded from these evidences that it is possible to perceive prototypicality of the senses of prepositions. However, the question as to the extent to which one sense is more prototypical than the others, for people other than the analyst, remains unanswered.

I asked 13 native students of a correspondence course in English at the University of Birmingham to put nine sentences containing different senses of *into* in order of their prototypicality on a continuum. Table 3.9 below shows their answers to the nine sentences to which numbers from 'i' to 'ix' were assigned. The participants were made anonymous by labelling them 'A' to 'M', and my hypothesised order is also shown in the Y column. My hypothesis is that the locative and movement sense comes to the top of the list, while the other metaphorical senses are lower. This hypothesis was proved plausible. Firstly, the 'penetration'³ sense, in *It was when Charles came into the room* <S1A-018 #256>, was observed to be in top place in most of their answers (11 out of 13, 85%). Secondly, the senses which can be bodily experienced tend to be placed in high ranking following the movement

³ More details of the senses of *into* are provided in Chapter 7.

EXAMPLES		A	B	C	D	E	F	G	H	I	J	K	L	M
i	<i>It was when Charles came <u>into</u> the room.</i> <S1A-018 #256: P>	1	3	1	1	1	2	1	1	1	1	1	1	1
ii	<i>The door opened directly <u>into</u> the living room.</i> <W2F-006 #054: O>	3	1	1	3	3	1	2	3	2	2	2	3	2
iii	<i>Mr Les Crewes, whose daughter Joanne died when Lambert's Daimler crashed <u>into</u> a sports car last May, said he had no sympathy for the man behind the wheel.</i> <S2B-017 #055: SE>	2	2	1	2	2	3	3	2	3	3	3	2	3
iv	<i>Guy, how did you get <u>into</u> this business of theatre composing?</i> <S1B-023 #008: IN>	4	9	1	8	4	5	4	7	6	7	5	4	5
v	<i>In the deepening recession good companies as well as bad are being <u>plunged into</u> liquidity problems.</i> <W2E-002 #103: IV>	7	6	1	8	6	8	5	4	5	9	6	8	5
vi	<i>He told his audience that a common currency could evolve <u>into</u> a single currency but only as a result of the choice of governments and peoples and not by imposition.</i> <S2B-017 #043: MP>	8	5	1	9	7	4	7	5	7	8	8	9	6
vii	<i>Fanathinikos to their credit have brought a positive approach <u>into</u> this game.</i> <S2A-018 #231: P>	5	4	1	8	5	7	6	8	4	7	4	6	4
viii	<i>The immense power of chemicals has seduced us <u>into</u> believing that we can lord it over nature.</i> <W2B-027 #011: AC>	9	7	1	9	9	6	8	9	9	9	9	7	6
ix	<i>A government inquiry was set up in 1934 to look <u>into</u> the future of television broadcasting and decided that a service should be set up and run by the BBC.</i> <W2B-034 #044: CO>	6	8	1	9	8	9	9	6	8	9	7	5	5
The codes in the bracket represent the sentence code of the ICE GB corpus. The following letters indicate the sense of <i>into</i> : P, penetration; O, orientation; SE, affecting surface, embedded; IN, involvement; MP, metamorphosis; AC, starting an action; CO, concerning/about.														

Table 3.9 Questionnaire on the degree of concreteness of *into*

sense: the ‘orientation’ sense, as in *The door opened directly into the living room* <W2F-006 #054>, and the ‘affecting surface’ sense, as in *...when Lambert’s Daimler crashed into a sports car last May*, <S2B-017 #055>. Thirdly, the other senses were given degrees of prototypicality from four to nine. In other words, those senses were considered less prototypical than the senses of ‘penetration’, ‘orientation’ and ‘affecting surface’. It can, therefore, be concluded that the senses of prepositions can be arranged in the order of prototypicality.

It should be noted that arrangement in the order of prototypicality is unlikely to be clear-cut, but is rather as fuzzy as semantic category (see section 2.1 above). For example, participants J and M (shaded columns in Table 3.9) assigned the same number to more than one sense. Moreover, participant B provided all the senses with number one (the most prototypical) and commented that all the senses fundamentally signify a movement from outer to inner. This seems to imply that we see the prototypical sense extend metaphorically into the other senses.

3.4 Summary of the chapter

This chapter has presented the data and the methodology of this research. Despite its relatively small size of one million words, the ICE GB corpus represents a wide variety of spoken and written forms of language and the parsed data in the corpus help me to specify the TR and the LM in relation to the prepositions *over*, *into* and *through*. If the correlation between the sense and the form is observed, the HCA combinations of the TR and the LM according to the classification criteria may allow us to describe the polysemous senses of the prepositions in terms of their collocations and patterns. The HCA combinations also have the potential to provide an alternative account of the semantic network of prepositions by mapping the senses in the diagram on the basis of the collocations. In the following chapters,

the analyses of *over*, *into* and *through* are given for the purpose of testing the hypothesis that there is a relationship between sense and collocation.

4. PILOT STUDY: TR AND LM COMBINATIONS IN SEVEN PREPOSITIONS

This pilot study tested the hypothesis that the trajector (TR) and landmark (LM) noun combination differs as regards prepositions and can characterise their language behaviour. One hundred concordance lines for the seven prepositions, namely *in*, *on*, *at*, *against*, *over*, *through* and *into*, following the verb were extracted from the Bank of English. The phases of the verb (VB) and the preposition were selected in the following manner. First, the wordlist was compiled in order to see which prepositions occur frequently. Table 4.1 below shows that monosyllabic prepositions occur most frequently, followed by prepositions with more than two syllables. Subsequently, the incidence of verbs with these prepositions in the Bank of English was tabulated in comparison with those of the prepositions.

	raw frequency		
1 VB+ TO	1,068,594	OF	1
2 VB+ IN	408,529	TO	2
3 VB+ ON	273,909	IN	3
4 VB+ FOR	243,437	FOR	4
5 VB+ WITH	239,194	ON	5
6 VB+ AT	148,926	WITH	6
7 VB+ ABOUT	120,091	AS	7
8 VB+ FROM	112,533	AT	8
9 VB+ AS	107,166	BY	9
10 VB+ OF	91,655	FROM	10
11 VB+ INTO	80,631	ABOUT	11
12 VB+ BY	48,451	THAN	12
13 VB+ OVER	47,961	AFTER	13
14 VB+ LIKE	43,507	INTO	14
15 VB+ THROUGH	42,357	LIKE	15
16 VB+ AFTER	23,968	OVER	16
17 VB+ AGAINST	20,007	THROUGH	17
18 VB+ WITHOUT	13,129	AGAINST	18
19 VB+ BETWEEN	12,336	BETWEEN	19
20 VB+ THAN	6,266	WITHOUT	20

Table 4.1 Incidence of VB + preposition in the Bank of English and the ranking of frequent prepositions

The distribution of human beings (H), concrete objects (C) and abstract objects (A) of the trajector (TR) and the landmark (LM) was statistically tested by the chi-square test,

which indicates departures in the observed frequency of occurrence from the expected frequency indicated by the total distribution. Subsequently, the residuals were employed between the observed and the expected frequencies to carry out a cluster analysis. This provided a dendrogram to show the HCA distribution pattern common to the prepositions. Note, however, that a dendrogram is supposed to indicate a tentative linkage amongst variables on a statistical basis and further investigation is required to discover how far the dendrogram can explain the clustering of the prepositions. The significant combination of H, C and A with their concordance lines is in turn detailed in relation to the clustering of the prepositions shown in the dendrogram.

4.1 Chi-square test of the distribution of HCA combinations

Appendix 1 illustrates the 3x3 distribution composed of human beings, concrete objects and abstract objects in combination with prepositions. The TR and LM nouns which precede and follow an active verb and preposition fall into the categories of HH, HC, HA, CH, CC, CA, AH, AC and AA – these pairs of letters represent the TR and the LM object. In other words, HH stands for the combination of human being TR and human being LM. The distributions containing *on* (p=0.0066), *at* (p=0.0022), *over* (p=0.0008), *through* (p=0.0002) and *into* (p=0.0001) turn out to be statistically significant, whereas the TR and LM of *in* (p=0.3704) and *against* (p=0.055) are not distributed significantly in terms of the HCA classification. As a result, the residuals of the significant frequencies are analysed to discover which TR and LM combinations can be called significantly distributed:

OVERUSE		TR		LM	frequency	
+***	p < 0.001	A	<i>at</i>	A	24	AA
		C	<i>over</i>	C	14	CC
		C	<i>through</i>	C	21	CC
		A	<i>into</i>	A	16	AA
+**	p < 0.01	C	<i>on</i>	C	9	CC
		H	<i>at</i>	C	28	HC
		A	<i>over</i>	A	12	AA
		C	<i>into</i>	C	13	CC
+*	p < 0.05	A	<i>on</i>	A	22	AA
		A	<i>through</i>	A	9	AA
		H	<i>into</i>	H	7	HH
UNDERUSE						
-***	p < 0.001	H	<i>at</i>	A	30	HA
		A	<i>at</i>	C	1	AC
		C	<i>through</i>	A	3	CA
		A	<i>into</i>	C	3	AC
-**	p < 0.01	C	<i>over</i>	A	2	CA
-*	p < 0.05	A	<i>on</i>	C	3	AC
		A	<i>over</i>	C	3	AC
		H	<i>through</i>	C	27	HC
		A	<i>through</i>	C	2	AC
		C	<i>into</i>	A	2	CA

Table 4.2 Overuse and underuse of subject and object combinations

Table 4.2 shows that the CC combination occurs excessively with *over*, *through* and *into*, for example in (1), (2) and (3) below. This implies that it might frequently be expressed in everyday language that a concrete entity as the TR, which is the agent of action, traverses another concrete object as the LM. In Example (1), the TR, *cloud*, is located in relation to the LM, *Norway*, and the TR and the LM of Examples (2) and (3) are related in a space configuration.

<overused CC>

- (1) There was a cloud hanging over Norway as they arrived for training at the Stade Lescure.
- (2) Mr Jones said the toddler's teeth had also gone through her lips.

- (3) Two people died when a commuter train crashed into the buffers at the station.

Similarly, abstract objects in combination with abstract objects (AA) are frequently used in terms of the TR and LM combination (Examples 4-7). Given that a concrete object traversing an entity is physically experienced on a regular basis in the lives of language users, such physical experiences establish mental representations of CC combinations illustrated by the TR and the LM. The mental representation of a spatial configuration, which is associated with ‘image schemas’ (see section 2.3 above and cf. Johnson, 1987: 126), can be metaphorically projected onto the TR and LM relationship between abstract objects. Example (5) shows that an abstract object, *the secret to its success*, is described as being situated in an abstract position, *a lower level*, as though the secret were physically placed at some point in space. Consequently, the overuse of CC and AA could imply a ‘parallel configuration’ in which the TR and the LM are concrete objects or abstract objects. The configuration, which derives from physical experience and their metaphorical projection, is frequent in language.

<overused AA>

- (4) But if the real power of the model lies in gauging the performance of the whole organ, the secret to its success lies at a lower level.
- (5) However, the wedding industry has since grown into a competitive, pressure-selling industry and after five years,...
- (6) And as my initial meaning to my clients will change over time, so will theirs to me.
- (7) ...but against calcite the angle depends on the proportion of carbon dioxide to water;...

Underused combinations, such as CA and AC, clearly indicate that non-parallel configuration appears to be infrequent. Again, drawing on the thesis of image schemas,

mental representations applicable to language originate from physical experiences. The scarcity of CA and AC may be due to the fact that the configuration cannot be directly observed by language users. Take Example (8), for instance: it is impossible to see *the flames* pass through *my heart*, and so the configuration of the TR and the LM is described metaphorically. Likewise, in (10) the abstract object, *quality*, co-occurs with concrete objects, *French products*. These non-parallel combinations turn out to be underused.

<underused CA>

- (8) 'At one point I stood in the fire and **the flames** came through **my heart** as light came through...
- (9) **They [islands in the South Pacific]** went into **myth** because no one could tell if what they had seen was true.

<underused AC>

- (10) **It [quality]** excels in **French products**, notably wine, dairy and even bread.
- (11) **Tension** rises over **salmon**, by Danny Westneat, Seattle Times staff reporter: Tension is rising again between Native Americans and non-Indians over salmon,...

Despite the fact that CC and AA combinations were generally overused, the same category of the TR and LM in parallel was not used frequently, nor were expressions based on physical experiences alone. Only HH with *into* (p=1.969) is somewhat overused, but the combination with other prepositions is not. It is highly likely that a human being will relate to a concrete object (HC), e.g., *You walk into a room*, should it be the case that physical experiences are closely linked to mental representations in the use of language. It could also be suggested that such expressions associated with direct experiences are prototypical, in comparison to figurative expressions. Nevertheless, HC is solely overused with *at* (p=3.113) referring to a place where an action is performed and, surprisingly, HC with *through* (p=

-2.306), co-occurring with verbs denoting movement, is underused.

To sum up, the summary provided by the overuses and underuses of the HCA combinations of the TR and the LM is as follows:

- The distributions containing *on* ($p < 0.01$) and *at* ($p < 0.05$) are significant and those with *over* ($p < 0.001$), *through* ($p < 0.001$) and *into* ($p < 0.001$) turn out to be highly significant.
- CC and AA combinations are overused, while CA and AC are underused.
- CC overuse with *over*, *into*, *through* and *on*;
AA overuse with *at*, *over*, *into*, *through* and *on*;
CA underuse with *over*, *into* and *through*;
AC underuse with *at*, *over*, *into*, *through* and *on*

4.2 Cluster dendrogram and analysis of the clustering

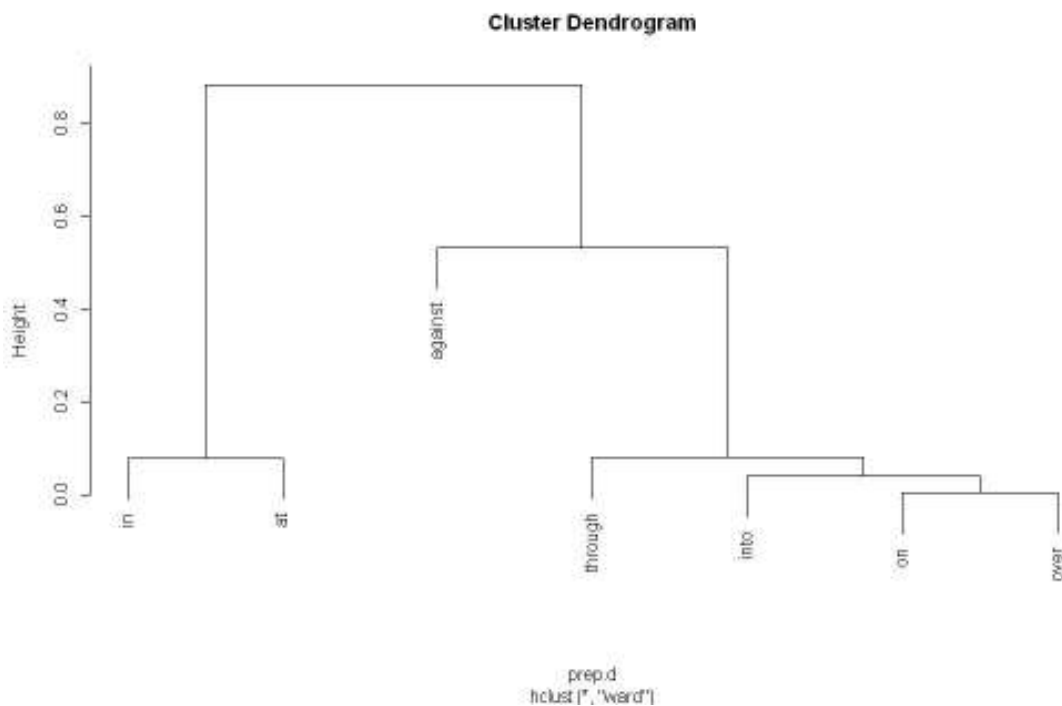

Figure 4.1 Dendrogram of the residuals of HCA combinations

The dendrogram is formulated by the correlation of variables which are clustered according to relative distance. However, as mentioned earlier, this clustering is thought of as tentative, not

conclusive. Thus, another study is required to interpret clustering. Figure 4.1 above illustrates the clustering of HCA (human beings, concrete objects and abstract objects) in distribution, based on the values of the departures (= residuals) from the expected frequency. In other words, the dendrogram indicates the resemblances of HCA distributions in the preposition groupings. To provide a detailed account of the clustering, Table 4.3 below shows the residuals of HCA combinations; the overused and underused combinations, with the preposition groupings, are put in order of the similarity of their distribution patterns.

	HH	HC	HA	CH	CC	CA	AH	AC	AA
OVER	1.839	-1.053	0.113	-1.197	3.542	-2.934	-1.153	-2.273	2.866
					****	**		*	***
ON	1.709	-0.455	-0.503	-1.089	3.196	-2.469	-1.072	-1.796	2.313
					***	*			**
INTO	1.969	0.422	-1.441	-1.153	3.081	-2.517	-1.329	-3.314	4.032
	**				***	*		***	***
THROUGH	1.498	-2.306	1.725	-1.147	4.215	-3.777	-0.718	-2.237	2.527
		*			****	***		*	**
AGAINST	0.243	-2.181	1.410	-1.558	2.572	-0.422	0.996	0.352	-1.237
IN	-0.879	1.494	-1.181	0.533	0.090	-0.271	0.533	-1.900	1.703
AT	0.958	3.113	-3.541	-0.915	0.639	-0.048	-0.526	-3.689	3.806
		***	***					***	***

Table 4.3 Residuals and significant overuses and underuses

On the whole, as discussed in the previous section, the overuse of CC and AA, and the underuse of CA and AC, individualise the clustering of the groups *over*, *on*, *into* and *through*. Among these, *over* and *on* are found to cluster together more favourably than the other prepositions. Contrastingly, the co-occurring verbs may shed light on preferential clustering: *over* and *on* tend to follow verbs denoting static situations, such as *hanging*, *lying*, *extending*, *fitting* with *over* and *lying* and *left* with *on*. By contrast, *into* and *through* are prone to occur with verbs denoting movement from one place to another: *digging*, *came*, *flood*,

fallen with *into* and *passed*, *break*, *had gone*, *move*, *echoed*, *running* with *through*, as in Examples (12) and (13) below respectively.

- (12) They [positively charged sodium ions] flood into the cell from outside, where their concentration is high, bringing their positive charge with them.
- (13) The wooden clogs of the strolling musician echoed through the empty, frozen streets with a clear, hollow clop-clop sound...

The cluster composed of *over* and *on* then merges with *into*. The preposition group is characterised by the overuse of the HH combination in terms of statistical testing. The residual (1.969) appears to be significant, despite the fact that it does not differ very much from *over* (1.839) and *on* (1.709). Given that HH with *through* accounts for 1.498, the combination of the trajector and landmark of human beings in terms of the four prepositions tends to be overused although the residuals, except for *into*, are statistically insignificant. As a result, it can be inferred that parallel combinations HH, CC and AA show positive residuals relevant to overuse. Interestingly, the HC combination of *into* characteristically indicates a positive residual in contrast with the negative residuals of *over*, *on*, *into* and *through*; *in* and *at* are also overused in the combination. By studying the verbs I attempted to discover relevance in the meaning, but could find only basic locative meanings in both the positive and negative HC combinations.

Through is merged into the cluster *over*, *on* and *into*. The underused HC combination (-2.306) and the positive residual of HA (1.725) are distinctive, as is the distribution of *through*. With the verbs *GO*, *COME* and *PASS*, the HC combinations represent the lapse of time or experience (Example 14).

- (14) I think it's difficult you know I'm not sure of – I think the group did go through a time where it felt quite cohesive and bonded but I think it's sort of disintegrated again...

Subsequently, *against* is clustered at approximately a 0.5 correlation value. This merger suggests that the HCA combinations are distinguished from the prepositions in the other cluster branch. However, the shared features of *against* can be inferred from the residuals: the HC (-2.181), CH (-1.558) and CC (2.572) are closer to the cluster than *in* and *at* appear to be, while at the same time the monosyllabic prepositions make a cluster at the other margin.

The *in* and *at* cluster appears at the other side of the other prepositions. This may be due to the distinctive pattern individualised by the HC (1.494 and 3.113), the CC (0.090 and 0.639) and the CA (-0.271 and -0.048), and then the distribution pattern of the residuals runs counter to those of the other prepositions. The overuse of HC may imply that *in* and *at* tend to be used for a person acting in/at a certain place.

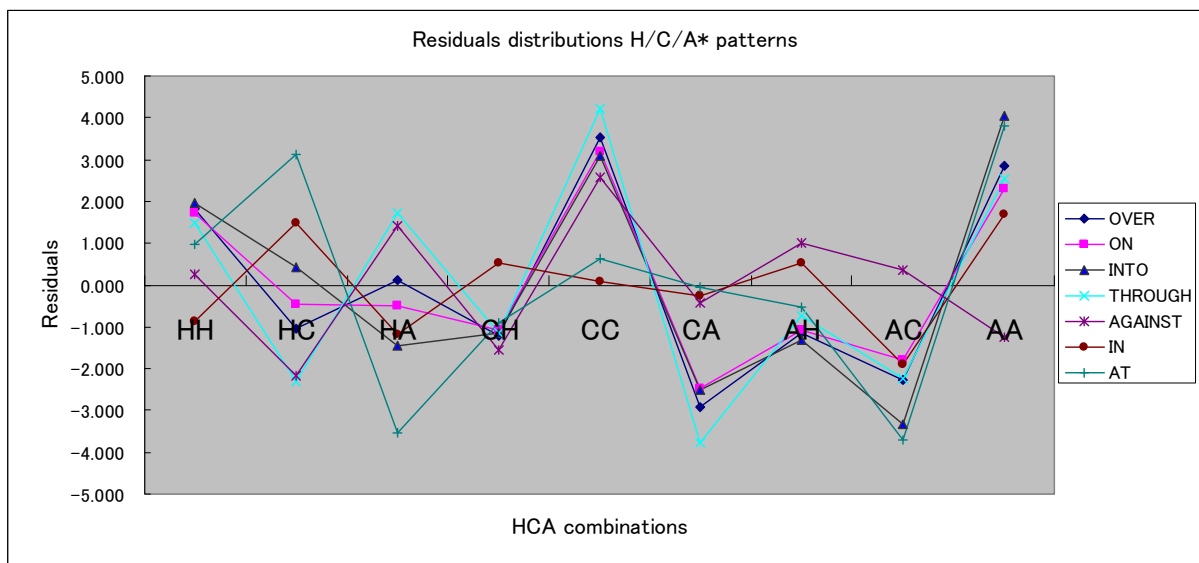

Figure 4.2 HCA distribution patterns in the trajector-centred order

Figure 4.2 illustrates the distribution patterns of HCA combinations with the lines representing the residuals in the preposition groups. It is obvious that the distribution patterns of *over*, *on*, *into* and *through* appear to be identical; this pattern sharply increases at the CC

and the AA and decreases to negative residuals at the CA, the AH and the AC. *In* and *at*, in contrast, remain relatively steady at around the neutral value of residuals. As regards human being TR combinations, the HH, the HC and the HA are randomly scattered in positive and negative residuals.

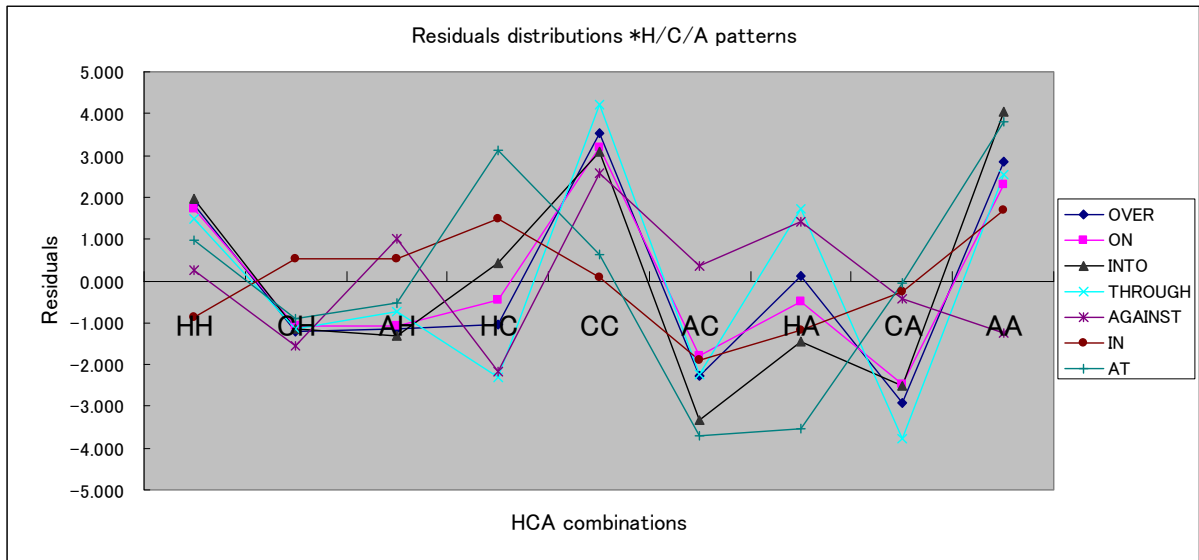

Figure 4.3 HCA distribution patterns in the landmark-centred order

Figure 4.3 above shows the HCA distribution pattern of the manner in which the landmark is centred. In the combinations with human being objects, the HH, the CH, and the AH, suggest that the parallel combination HH is overused while the other but non-parallel CH and AH are underused. Interestingly, the distributions of *in* and *at* are found to be distinct from the other prepositions: the CH, the AH and the HC with *in* are overused, while the residuals of the others are underused, and the distribution line of *at* demonstrates an excessively overused HC and underused AC and HA. This could imply that *at* tends to be used to indicate that a human being is staying at or performing at a certain location. In summary, this section has attested the following:

- The dendrogram in Figure 4.2 demonstrates the clustering of the prepositions under review according to the residuals of the HCA combinations.
- The distribution patterns of the residuals explain the reason for the clustering.

4.3 Summary of the chapter

This pilot study has investigated how the distribution of the trajector (TR) and the landmark (LM) combinations differs for the seven prepositions: *in*, *on*, *at*, *against*, *over*, *through* and *into*. The distribution of HCA combinations indicates the different linguistic behaviour of the TR and LM collocates. The residuals, based on the frequency of the HCA combinations, provide a dendrogram of the prepositions. The distribution patterns of the combinations are effectively interpreted by the clustering and reveal how the HCA combinations are frequently found in the similar pattern of the prepositions. As a result, the combinations of *on*, *at*, *over*, *through* and *into* appear to be significantly distributed. Of these prepositions, *on*, *over*, *through* and *into* fall into one branch of the dendrogram, indicating that their distribution pattern of the HCA combinations is similar. Although the HCA combinations with *on* seem worth investigating, the polysemous senses, which vary among the forty-three senses presented in *Collins COBUILD Advanced Learner's English Dictionary* (Sinclair *et al.*, 2003), are too diverse to examine here.

Over, *into* and *through* were investigated in this study for the following reasons. First, these prepositions appeared to fall into the same branch of the dendrogram, based on the distribution pattern of the HCA combinations. Second, the prepositions have a similar mental representation of the spatial configuration. The 'path' movement, which seems to relate to the 'path' image schema (see section 2.3 above), is shared in the prototypical sense of *over*, *into* and *through*. Third, some research into the senses of *over* has been undertaken (Brugman, 1981; 1988; Dewell, 1994, Lakoff, 1987; Tyler and Evans, 2003a) and this is comparable with the results of this study. In the following chapter, the preceding studies are revisited, to see

whether the hypothesis of HCA combinations is compatible with them.

5. THE MEANING COMPONENTS OF *OVER*

5.1 The polysemy and semantic network of *over*

Prepositions are considered to be words which bear several meanings, even though their linguistic form remains consistent. For instance, the preposition *over* can denote several different physical and non-physical relationships between two entities.

- (1) They 're, [...] they 're now flying over us <S2A-019 #096>¹
- (2) Now Tony we'll just go over the basic procedures to start your bike before you sit on it... <S2A-054 #053>

The examples above indicate a spatial configuration and a metaphorical relation using *over* as in (1) and (2). Although the identical linguistic form *over* is used, the meanings are distinct from one another. Example (1) can be paraphrased as being located “above and across”, while (2) implies that the agent somehow metaphorically “transverses and inspects” the procedures.

Polysemy has been discussed in linguistics from two viewpoints. In earlier research, it was contended that a polysemous word incidentally happens to bear different meanings as a homonym, a word which is pronounced the same as another word but conveys different information: *bank* was assumed to have the meanings both of a financial organisation and of the higher land bordering a river. However, this is not the case for prepositions, because the different meanings provide a common image, blending a primary sense of the preposition and the way in which language users intuitively perceive it. Take *over*; for example: the uses of *over* in (1) and (2) signify different things but at the same time share the proposition of ‘an entity traversing another’ which is understood, and the meanings attributed to *over* are all likely to derive from the central schema. Consequently, prepositions are assumed not to have several wholly disconnected meanings, but to establish a lexicon for their users based on a

¹ The code number in brackets represents the data code and sentence number of the ICE GB. All the instances with brackets hereafter are excerpts of the corpus.

principled core schema of spatial configuration (Tyler and Evans, 2003a).

Cognitive linguists set out to explore semantic networks on the basis of human construal, human ways of seeing the world, and they attempt to account for the functioning of the categorization of meanings in networks. It is postulated that different meanings of a polysemous word form a semantic network which extends from the primary sense (Rosch, 1975) to its sub-categories, described as a 'radial category' (Lakoff, 1987). The members of the categories do not necessarily share the same features; rather, some particular features are shared by some of the members – cf., Wittgenstein's 'family resemblance' (Wittgenstein, 1953) – and the semantic network is fuzzily composed of the central schema and the derived senses on the periphery (Zadeh, 1965)². In the same way, the semantic networks of prepositions have been described as a radial category (Dirven, 1993; Sandra and Rice, 1995; Tyler and Evans, 2001, 2003a and 2003b). The core schema of prepositions is thought to closely relate to kinaesthetic experiences (Lakoff, 1987; Lakoff and Johnson, 1999). This is largely because the spatial configuration represented by a preposition is learned by means of experiencing it in routine, everyday activities. Kolstad (1991) (cited in Mandler, 1992) shows that a baby as young as five-and-a-half months old was surprised to see that a container without a bottom, which was constructed for the purpose of the experiment, could hold something inside it. This implies that even infants recognise the violation of embodied principles, in this case, containment. In addition, basic embodied experiences are considered to generate mental representations of spatial configurations, such as CONTAINER, UP-DOWN, FRONT-BACK, IN-OUT, SURFACE, SOURCE-PATH-GOAL and other image schemas (Lakoff, 1987; Lakoff and Johnson, 1999). Cognitive linguists argue that the central meaning of prepositions originates from their mental representation based on embodied experiences; the derived senses, which are associated with one another as sub-schemas in the semantic network, are

² See section 2.2.2 'Semantic network' for more details.

invoked by means of foregrounding a particular feature of the central meaning. In other words, the core meaning of *over*, above and across, is embodied by the experiences in which we repeatedly see one entity go over another, as seen in (1), and a salient feature of the central schema, such as eye movement across and throughout, is extended by *over* to give the sense of examining, as in (2).

The studies of *over* attempt to explore the nature of the polysemous preposition on the basis that human construal and embodied experiences assign the following attributes to the establishment of the semantic network:

- the central schema of the preposition and the rationally derived meanings
- the motivations which associate the core meaning with the derived
- the sentential components which are involved in implying the derived meanings

This approach seems in a way analogous to investigating the evolution of the animal kingdom. The research is carried out by comparing similar kinds of animal and classifying them into sub-categories in a tree diagram and deriving the root of the animals in a particular family from the evidence of fossil animals. In like manner, linguists set out the semantic network of a preposition which is composed of its different meanings and illuminate its central concept in its relation to kinaesthesia and perception. In the following section, we will see how research in cognitive linguistics has illuminated the understanding of the central schema, motivations and relevant components of the meanings of *over*.

5.2 The case studies of *OVER*

5.2.1 The central schema of *OVER*

The polysemous aspects of *over* were first thoroughly examined in relation to human

cognition by Brugman (1981, 1988) and Lakoff (1987). Brugman challenged the then current proposition that the multiple meanings of a lexical item were arbitrary and irrationally associated as homonyms, and concluded that seemingly disparate meanings of *over* are interrelated by mental representations generated through embodied experiences. Drawing on her analysis, Lakoff (1987) argues that ‘image schemas’, conceptual prototypes to encourage the understanding of spatial configurations, are likely to play an essential part in interpreting the diverse meanings of *over*. This assumption in turn gives rise to the primary mental representation of *over* (Figure 5.1 below) and the central schema is exemplified as in (3):

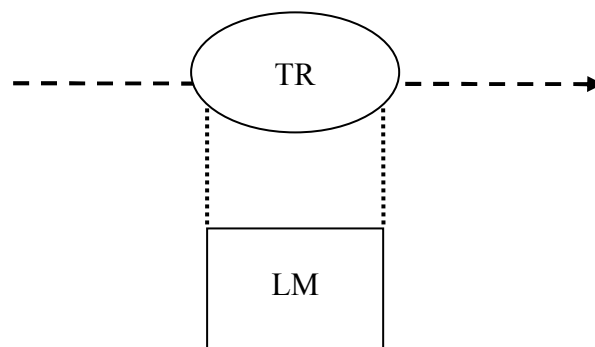

Figure 5.1 The central schema of *over*, adapted from Lakoff (1987: 419)

- (3) The plane is flying over the hill.
- (4) Sam walked over the hill.
- (5) Sam climbed over the wall.

As seen in the figure above, the central schema of *over* suggested by Lakoff (1987) represents the linear, flat movement of the trajectory (TR), which is the focused entity of the two referents in the sense of disposition in space, above and across the landmark (LM), the other entity functioning as background (Langacker, 1987). The drawback of this central schema is that a number of ad hoc trajectories caused by the outline of landmark are subsumed within the derivable senses of *over* (Tyler and Evans, 2003a): the trajectory of (4) is

a path curved in an arc along the profile of the hill, while that of (5) climbs up and down tracing the rectangular shape of the wall. Given that prototypical schemas can vary to a certain extent, Lakoff's semantic network of *over* is overwhelmingly complex, due to the semantic attributes of contact, horizontal/vertical extension, and end-point focus. In contrast, Dewell (1994, 2007) suggests that the core schema of *over* is a curved arc trajectory (Figure 5.2 below). His prototypical representation is assumed to exclude the unnecessary settings of landmark in terms of outline, and he points out that *over* denotes the LM under the influence of the TR, unlike *above*, which conveys the detachment of the TR from the sphere of the LM (cf. *Keep your head above [*over] water.* (ibid.: 374).

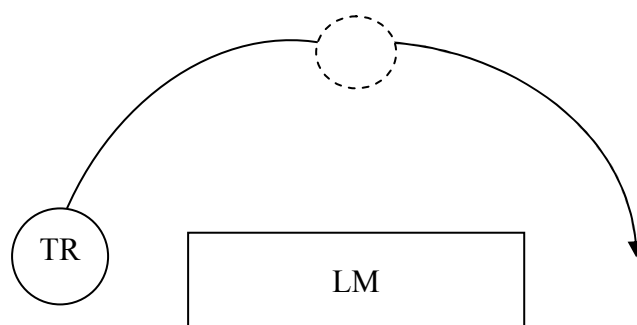

Figure 5.2 The central schema of *over*, adapted from Dewell (1994: 353)

Figure 5.1 and Figure 5.2 illustrate that the central schemas presented by Lakoff (1987) and Dewell (1994) provide a description of *over* as 'path', a route caused by movement from one place to another, rather than a static spatial relationship between TR and LM. It should, however, be noted that, given that cognitive linguistics relies mainly on human construal, the rationale seems to a large extent subjective and intuitive and it is difficult to establish objective criteria. Contrary to this, the 'proto scene' of *over* (Figure 5.3 below), the mental representation of spatial configurations related to prepositions, is defined on the following grounds: 1. earliest attested meaning, 2. predominance in the semantic network, 3. use in composite form, 4. relation to other prepositions, and 5. grammatical predictions (Tyler

and Evans, 2001, 2003a, 2003b). ‘The earliest attested meaning’ is identified by the diachronic development of the meanings of the preposition, and the original meaning is assumed to be associated with the primary sense, namely that *over* originates from the Sanskrit *upari* denoting ‘higher’ and the Old Teutonic comparative form *ufa* denoting ‘above’ (Tyler and Evans, 2003: 48). Its ‘use in composite form’ suggests that the *over* sense denoted in compound words and phrasal verbs, such as *overlook* and *look over*, can be directly attributed to the primary sense. ‘Predominance in the semantic network’ indicates the extent to which the central meaning is associated with the other members of the semantic network. It thus follows that the most common configuration of derived senses is a plausible candidate for being the primary sense. A relationship to other prepositions is likely to challenge the central schemas of Lakoff (1987) and Dewell (1944), because the diagrams are unlikely to distinguish the sphere of *over* or *above*. ‘Grammatical prediction’ indicates the traceability of derived meanings to the primary sense, which elucidates the semantic extension of the meanings (Tyler and Evans, 2003a). Tyler and Evans’ central schema, unlike those of the previous two writers, represents a static spatial configuration and not a path. It should be borne in mind that it is still under debate whether path or static configuration is more likely as the central schema of *over* (Dewell, 2007, Gucht *et al.*, 2007). Hence, the three candidates for the primary scene of *over* remain somewhat plausible and reasonable. The following section will discuss how the derived senses emerge and are associated with one another in the semantic network.

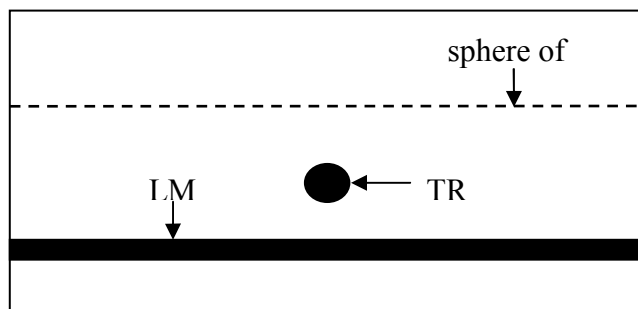

Figure 5.3 The proto scene of *over* (after Tyler and Evans 2003a: 66)

5.2.2. Motivations behind the semantic network

A key tenet of cognitive linguistics is that human construal and perception specifically relate to the use and system of language (Lakoff, 1987; Lakoff and Johnson, 1999; Langacker, 1987; Talmy, 2000; Ungerer and Schmid, 2006). Such flexible construal allows image schemas, conceptual prototypes of interpretation, to extend the applicability of a word and transform the prototype into an ad hoc interpretation. To put it another way, perception can be transformed, such that the end-point is foregrounded in the course of the path (path focus \Leftrightarrow end-point focus); scattered points are seen as a plane surface in aggregate when observed from a distance (multiplex \Leftrightarrow mass). These alternations of perception which accurately reflect our embodied experiences are defined as ‘image schema transformations’ (Dewell, 1994; Kreitzer, 1997; Lakoff, 1987) and in this manner facilitate the extension of meanings in a semantic network.

In addition to image schema transformations, metaphor and convention in language are involved in the extension of meaning and the establishment of a semantic network. Metaphor functions as not only a tool of rhetoric in literature and speech, but also as a representation of the foregrounding of a salient feature and its mapping onto a figurative setting. For instance, the control sense of *over* – e.g., *...or even when he told a British audience: We in India have long ago forgiven you for ruling over us.* <W2B-011 #070> – is likely to derive from a metaphor that people located above have authority over other people below. Such a metaphor may originally have emerged by the projection of a primary sense; nevertheless, as the figurative use is reiterated over years, it is conventionalised as a social and cultural norm in language. Take the temporal sense of *over*; for example; the locative senses of such prepositions as *in*, *on*, *at*, have been used since the remote past, and in a similar way *over* is conventionally used to denote the lapse of a certain period. Arguably, it might be difficult to clearly identify whether image schema transformation, metaphor, metonymy or

convention should be attributed to a derived meaning in terms of semantic extension. Rather, all of them may complement each other to create derived senses in the semantic network.

All possible interpretations of physical and non-physical configuration cannot be assumed to be derivable senses in a semantic network. Tyler and Evans (2003a: 55) point out that the member of a network, ‘sense’, should be differentiated from the ad hoc (to put it simply), above-located sense, as the proto scene shown in Figure 5.3 above, can be a member of the interpretation, ‘on-line meaning’, merely applicable to a particular configuration³, for example, to the semantic network of *over*, whereas an atypical spatio-configuration, as in *The hummingbird hovered over the flower* (Figure 5.4 below), should be treated as a temporary meaning of the member of the network. The distinction, however, remains disputable, since it rests on the criterion that the sense lies in the memory of language users (Lakoff, 1987) while the on-line meaning does not (Tyler and Evans, 2003a). Obviously, both are conventionally committed to memory through routine use; where they differ is that the sense is determined by partially sharing the principal features of a lexical item, whereas the on-line meaning is marginally extended. Therefore, I would agree that image schema transformations, metaphor, metonymy and convention are highly likely to be involved together in furnishing the senses of a semantic network and on-line interpretations (Dewell, 1994; Kövecses, 2002; Tyler and Evans, 2003a). In the next section, we will examine whether any other factor can determine the sense and meaning of *over*.

³ From here onward, I will use the term ‘sense’ as a member of semantic network as well as the meanings of the polysemous preposition *over*.

(TR)
(hummingbird)

LM (flower)

Figure 5.4 Configuration of an on-line meaning as in *The hummingbird hovered over the flower*

5.2.3. Sentential components of senses of *over*

Two mutually opposed suppositions can be made about sentential components. The interpretation of *over* can be determined either exclusively by the preposition which comprehensively illustrates any configuration between the TR and LM, ‘full specification interpretation’ (Lakoff, 1987), or by the preposition, the verb, and the object for which *over* provides a minimal configuration and the others provide complementary additional information, which is defined as ‘minimal specification interpretation’ (Lakoff, 1987: 420).

The studies of *over*, so far, despite their attempts to explore the senses of the preposition, seem to imply the involvement of other sentential components. Dewell (1994: 355-57) illustrates the trajectory of *over* by classifying examples into any of three types: downward, upward, and freeze-frame at the peak, giving the examples below (6)-(8):

- (6) Sam fell over the cliff. (downward trajectory)
- (7) The plane climbed right over the city. (upward trajectory)
- (8) The plane should be over Baltimore by now. (freeze-frame at the peak)

Obviously, the verbs – *fell*, *climbed*, *be* – to certain extent relate to the interpretation of the trajectories and it seems difficult to claim that *over* alone determines the different interpretations. Likewise, Kreitzer (1997: 299) accounts for the integration of the different

schemas, the dynamic path inferred by *climb* and *come*, and the static configuration denoted by *over* (Figure 5.5 below).

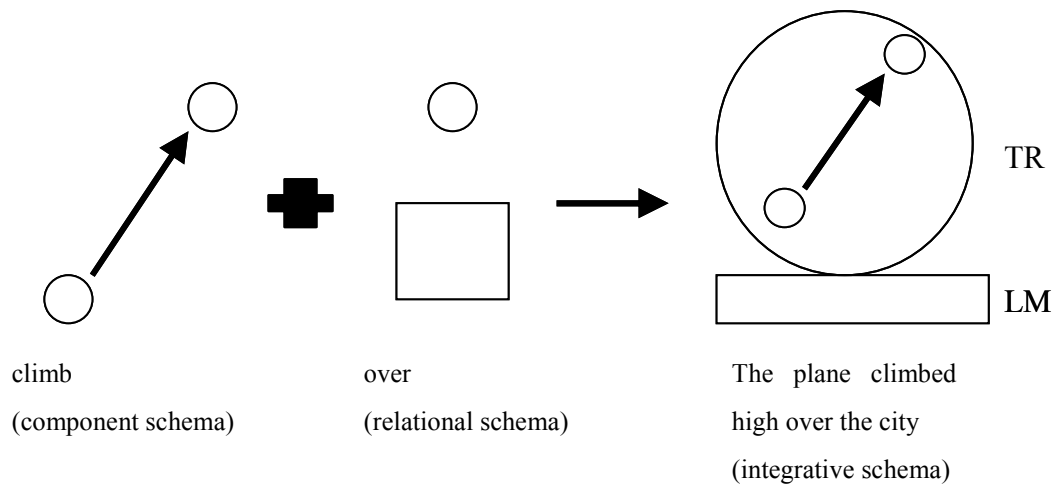

Figure 5.5 Component, relational, and integrative schema (Kreitzer, 1997)

Furthermore, Tyler and Evans (2001, 2003a, 2003b) point out that ‘world knowledge’ is essential in terms of the interpretation of language. Since encyclopaedic knowledge is obligatory in cognitive linguistics, the information on phenomena in the world is highly likely to be woven into the semantics. Take Figure 5.4 above again, for example; without the knowledge of hummingbirds, which can hover in the air, the mental representation of the configuration could hardly arise in the mind of the language user. It follows that the encyclopaedic knowledge of the bird and its relationship with flowers, its peculiar way of drinking the nectar, may give rise to the interpretation. Consequently, I would conclude that full specification interpretation is unlikely to account for the interpretation of *over*; rather, the involvement of other sentential components should be examined.

It is generally acknowledged that language refers to the real world; however, doubts arise over the claim that language represents all possible conceptualisations by the users:

The big bone of contention in contemporary cognitive linguistic theory is the extent to which language and conceptualisation are separable and how to prove that experimentally (Kleiner, 2005: 775).

Linguistic relativity, the discussion of how far language is associated with human construal, turns out to be the key to the exploration of the senses of *over*. I would agree theoretically that language functions as “a sufficient cue for conceptualisation” (Tyler and Evans, 2001: 743). Language, although ‘a minimal prompt’ (Tyler, 2006: 972), provides enough information to trigger a full conceptualisation to enable language users to communicate with each other. Corpus research is unlikely to reveal all the conceptualisations of language users through language, for here psychological elicitation experiment is needed, as Kleiner suggests; but corpus research could shed new light on the extent to which linguistic form prompts, and its combinations relate to, different senses. In the light of this rationale, in the following sections I carry out some corpus research into the relation between the senses of *over* and sentential components such as verb, subject and object.

5.3 Corpus research on the guiding senses of *over*

This section describes the research into the ICE GB corpus; this attempted to empirically explore in particular the distribution of the senses of *over* and the occurrence of verbs in these different senses. I will go through the senses of the semantic network of *over* suggested by Tyler and Evans (2001, 2003a, 2003b), since this network clearly illustrates the connections between the senses, the central and peripheral senses and the semantic extension from centre to periphery (Figure 5.6 below).

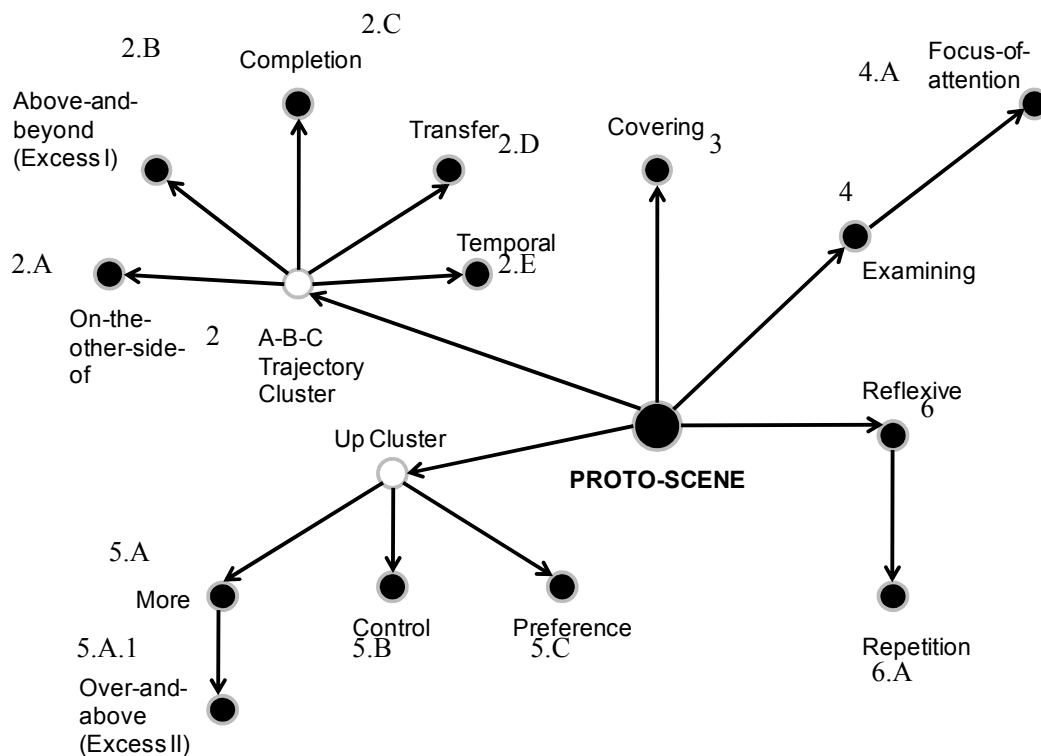

Figure 5.6 The semantic network for *over* (Tyler and Evans 2003a: 80)

Note, however, that some have cast doubt on the structure of the semantic network by challenging the central schema and motivation of the semantic extension. On the one hand, Dewell (2007) argues that the route sense, which corresponds to the A-B-C trajectory in Figure 5.6, is more probably appropriate as the primary schema in the sense that it should be the most predominant and derivable in a semantic network (cf. 5.2.1 The central schema of *over*). Although this may be true, Dewell fails to accommodate an alternative semantic network centring on the path sense. On the other hand, Gucht *et al.* (2007) claim that the covering sense is unlikely to be an independent sense, because the context enables us to topologically extend from the proto scene to the derived sense. But this proposition may discount most types of semantic extension. Consequently, the semantic network of Figure 5.6, in the present state of research, is most probably plausible. For this reason, this study draws primarily on the seminal work of Tyler and Evans (2003a).

This corpus research aims to discover the linguistic environment of the core and derived senses of *over* created in actual language use. The example sentences given by cognitive linguists tend to be somewhat artificial and plain in order to highlight the points of their argument. Empirical language data from a corpus could unveil a hidden association and pattern between the node word, in this study *over*, and other sentential components. Moreover, the frequency and infrequency of a particular sense in the semantic network could suggest which senses are recurrently experienced in the use of language. Unfortunately, the corpus data is unlikely to test the semantic network of Figure 5.6 since it is theoretically based on the five criteria discussed earlier in 5.2.1, unlike frequency and presence of words in which corpus research has its great strength. However, the frequency of the senses could add the conceptual model of the semantic network to empirical information as to which sense is recurrently experienced by using it. This implies that a frequent sense is more entrenched than other senses of the semantic network of language users. In the following section a corpus research will be undertaken.

5.3.1 Overview of the distribution of senses

This study analyses a parsed one-million-word corpus, the British Component of the International Corpus of English (ICE GB), for the purpose of finding the TR (subject) and LM (prepositional complement, noun phrase following a preposition) with the help of a parsed tree diagram. 480 instances containing the sequence of ‘verb + preposition *over*’, e.g., *look over*, were extracted and manually classified into the fifteen different senses shown in Figure 5.6 above. It should be noted that the senses of the semantic network intrinsically overlap each other: in other words, they are not clear-cut categories. However, for the purpose of the present research the instances examined were classified into the single most appropriate sense of the semantic network.

semantic network	Observed N	%	Expected N	Residual	std. residual	
1	40	8.3%	32.0	8.0	1.41	
2	2A	110	22.9%	32.0	78.0	13.79
	2B	18	3.8%	32.0	-14.0	-2.47
	2C	6	1.3%	32.0	-26.0	-4.60
	2D	19	4.0%	32.0	-13.0	-2.30
	2E	90	18.8%	32.0	58.0	10.25
3	43	9.0%	32.0	11.0	1.94	
4		13	2.7%	32.0	-19.0	-3.36
	4A	36	7.5%	32.0	4.0	0.71
5	5A	18	3.8%	32.0	-14.0	-2.47
	5A1	11	2.3%	32.0	-21.0	-3.71
	5B	50	10.4%	32.0	18.0	3.18
	5C	1	0.2%	32.0	-31.0	-5.48
6		18	3.8%	32.0	-14.0	-2.47
	6A	7	1.5%	32.0	-25.0	-4.42
	480	100.0%				

Table 5.1 Distribution of senses of *over* in the ICE GB

Table 5.1 illustrates the distribution of the senses: the observed frequency, the expected frequency, the residuals and the standardised residuals. The expected frequency is calculated on the hypothesis that the senses are equally distributed. Although admittedly they are not supposed to occur evenly, the expected frequency provides us with a benchmark of the distribution. Based on the difference in frequency between the observed and the expected, the standardised residuals are calculated according to a normal distribution.

The result shows that the distribution is localised in a few senses and the senses are overused: 2A on-the-other-side-of (110 instances, 22.9%), 2E temporal (90 instances, 18.8%) and 5B control (50 instances, 10.4%). The three senses occupy virtually half of the instances (52.1%). The other senses only account for less than ten percent each; in particular, the shaded cells are statistically underused. These findings in turn follow that the use of *over* is unequally distributed and frequently occurs in the given senses. This may imply that language users are recurrently exposed to particular senses of semantic network and the recurrent senses are possibly entrenched and closely associated with the word *over*; although they are the

peripheral senses in terms of the semantic network. This result draws a conclusion that the frequent sense is not necessarily the ‘core sense’ of semantic network (Shortall, 2007), largely because the prototype in cognitive linguistics is not defined by frequency, but by the versatility of the central schema. Nevertheless, the frequency of the derived senses suggests which senses the language user closely associates with the linguistic form of *over*.

5.3.2 Sense and the sentential components in the corpus

In this section, the instances containing *over* will be analysed in terms of the co-occurring components, such as verb and nouns, with the intention of revealing a tendency for the co-occurring words to relate to a particular sense of the semantic network shown in Figure 5.6. It should be noted that there exist no clear-cut boundaries amongst the senses, rather the senses overlap to a certain extent. The sense of *over* of (9) seems to denote that loose shirts are located on jeans as classified into proto scene (1) which represent the TR locating above the LM, while at the same time some may interpret the sense as covering (3) in that the shirts conceal the lower layer, jeans. Likewise, reading example (10) one may consider it as locating above sense that a cook has to stay at stove bending forward over a pan, while the *over* may possibly derive from a mental representation that a cook repeatedly stirs sauce in a pan as repetition sense (6A) (Littlemore, 2009 personal communication). It is possible that both interpretations are correct. The present study attempts not to apply stringent criteria of classification, but to distribute empirical instances from a corpus into a most reasonable one of the *over* senses for further research, taking into consideration the proposition of cognitive linguistics that our categorization is innately fuzzy (cf. section 2.1 above).

- (9) They are not allowed to wear very short skirts and they're not to wear allowed [sic.] to wear loose shirts over jeans. <S1A-054 #158>
- (10) ...you must have spent hours slaving over the stove. <S1A-071#316>

Furthermore, this research does not aim to analyse phrasal verbs, but to describe all the instances of verb and *over*, not being restricted by a conventional category of phrasal verbs. Phrasal verbs are two- or three-word clusters composed of a verb and a preposition or an adverb denoting an idiomatic meaning (Taylor, 2002). For instance, *put over* means successfully conveying ideas and opinions and explain them, as in *Minority groups had the chance to come into the studio and put over their point of view* (ibid.: 400, my underlining). Unlike the idiomatic meaning, the *over* of (11) literally signifies location. This study will thus provide a comprehensive account of co-occurring nouns and verbs as found in text, irrespective of phrasal verb or literal-meaning verb and particle combination.

- (11) Well, I am sure we could uh develop uh a very tasteful chiffon scarf of some sort, not to put over our heads and with our rollers underneath. <S1B-021 #077>

Again, I would like to confirm before investigation what will be analysed in the instances containing *over* in each sense of the semantic network:

- combination of trajector (TR) and landmark (LM)
- co-occurring verb
- pattern of phrase and clause structure

Proto scene (1)

The proto scene of *over* represents the TR as located above, and not necessarily in contact with the sphere of the LM (Figure 5.3 above). This static configuration schema arises from disputing the claim that the central schema of *over* is based on an above and across movement (cf. 5.2.1 the central schema of *OVER*). The central schema is exemplified in text as follows

(Tyler and Evans 2003a: 65, Lakoff 1987: 421)⁴.

(12) The picture is over the mantel⁵.

As Kreitzer (1997) suggests, let us assume that the verb preceding *over* may be involved in establishing the configuration. The following verbs occur in the sentences classified under the proto scene:

BLOW, CAST, HANG, HIT, HOOK, KNEEL, LEAN, LIFT, LOOM, PLACE, PLAY, PUT, ROAR, SHIT,
SLAVE, STAND, THWACK, TOUCH, WARM, WAVER, WEAR, WHIZZ⁶

No instance containing *BE over* is found in terms of the proto scene sense; however, HANG seems to denote a similar static state of the TR located above the LM. Now we will see the concordance lines of the corpus data. Interestingly, (13) alone shows a physical configuration, while an abstract entity in (14), *shame*, is metaphorically overlaid.

(13) A mist hung over the river. <W2F-013 #071>

(14) British resolve has been greater to get on with the conflict because the historical shame of the 1930s, when dictators were allowed to spread their evil across Europe unchecked, still hangs over us. <W2E-002 #050>

The outline of TR and LM can be transformed according to context. Such topological features are observed in the data. Unlike the proto scene, the TR forms into an extended outline as a human figure ((15) and (16) below). Although Lakoff (1987) claims that physical extension of TR and LM gives rise to a different sense, it is reasonable to assume that such a

⁴ From example (12) onward in section 5.3.2, unless specifically stated, the numbered examples without a code number and brackets are excerpts from Tyler and Evans (2003a), for the purpose of comparing their intuitively generated instances with corpus data.

⁵ The TR and LM are shaded in the examples from (12) onward.

⁶ The concordance lines containing the verbs are shown in Appendix 2 [pp. 327-358], TR and LM combinations with *over* in alphabetical order of verb and ICE GB sentence instances.

peculiar configuration is an application of the proto scene. This is because the transformation does not affect the configuration of the proto scene and it is accurately reflected in the knowledge of the world, in this case the shape of the human body.

- (15) She leaned over the washbasin to rinse her face and hands. <W2F-008 #139>
- (16) ...he growled, his voice wavering as he kneeled over her crouched body, his mouth close to her pretty ear. <W2F-008 #123>

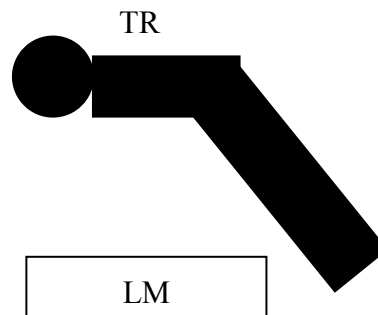

Figure 5.7 The mental representation of (15) and (16)

Likewise, the spatial configuration of (17) and (18) does not precisely correspond to the proto scene; the TR is located on the LM (Figure 5.8 below). The mental representation associated with the interpretation of (17) and (18) may derive not only from the verbs, TOUCH and PUT, but also from the prepositional complement, *the top* and *heads*. These findings naturally imply that the subject (TR) and prepositional complement (LM) are likely to help to accommodate a particular mental representation of the spatial configuration indicated by a preposition.

- (17) And it [the ball]'s just touched over the top of the crossbar, is it. <S2A-010 #175>
- (18) Well, I am sure we could, uh, develop, uh, a very tasteful chiffon scarf of some sort, not to put over our heads and with our rollers underneath. <S1B-021 #077>

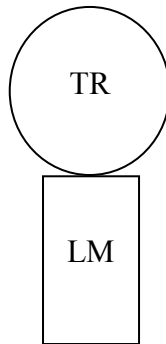

Figure 5.8 The mental representation of (17) and (18)

Most importantly, it should be noted that a non-physical entity is likely to assign a figurative meaning to the relation between TR and LM. Abstract nouns, *curse* and *threat*, can be assumed to be placed above and at the same time to *HANG over* (19) and *LOOM over* (20) connoting a negative ‘semantic prosody’ (Sinclair, 2003, 2004), evaluative meaning expressed by a phrase, with the help of the abstract TRs.

(19) Does some sort of curse hang over the place? <W2F-016 #069>

(20) But it’s a threat that still looms over him. <S2B-040 #064>

There exists a stark contrast between a static schema of *over*, spatial configuration representing an entity above the other (Tyler and Evans, 2003a), and path schema, arced movement from one side to another (Dewell, 1994). Obviously, the former schema can be assumed to require the involvement of two entities which function as trajector and landmark in terms of spatial scene (Langacker, 1987). It could, therefore, be hypothesised that the instances of *over* denoting static proto scene tend to retain a noun phrase, otherwise called prepositional complement (PC) with respect to prepositional phrase, functioning as ground after the preposition. Table 5.2 illustrates the presence of a PC following *over* which conveys a static sense in comparison to the phrase pattern, such as with or without direct object, and

passive.

	with prepositional complement	without prepositional complement
Verb + <i>over</i>	<i>blow, hang, hook, kneel, lean, loom, put, roar, shit, slave, waver</i>	
Verb + O + <i>over</i>	<i>cast, hit, thwack, warm, wear</i>	
BE V-ed + <i>over</i>	<i>lift, place, play</i>	

Table 5.2 Verbs and sentence structures in the sense of proto scene

No instance without a PC is found in the data. This implies that the proto scene sense cannot be independently used without a contrastive entity with the trajector. In addition to the presence of PCs, the phrase pattern is likely to characterise the sense of the spatial configuration. Examples (21) and (22) show that in order to indicate the focus on an object, such as *paw* and *transparent overlay* (TR), these sentences are in the passive voice with such landmarks (LM) as *object* and *display panel*.

- (21) Moreover if a paw was tapped just before it was due to be lifted **the paw** would then be reflexively lifted an increased amount, as if being lifted over an object. <W1A-016 #060>
- (22) Words, pictures or symbols are drawn on a transparent overlay and **this [overlay]** is placed over the display panel. <W2B-039 #083>

A similar configuration can be expressed in a different manner. For instance, examples (23) and (24) indicate that the TR, *hands*, hovers over the LM, *jars* and *bowl*. Whereas (23) denotes the hovering of hands alone, (24) adds the meaning of warming to the spatial configuration by emerging as verb + direct object + *over* structure.

- (23) You like? he asked, his hands wavering over jars of honey, marmalade and jam.
<W2F-013 #085>
- (24) Even then it's a welcome chance to warm freezing hands over a steaming bowl of food... <W2B-024 #101>

To sum up, the instances from corpus data have revealed that the proto scene *over* closely relates to such co-occurring words as TR, LM, verb as well as phrase pattern. A topological extension in particular is related to particular verbs retaining the spatial configuration the TR above the LM. The consistent presence of a noun phrase following *over* may imply the close association of the TR and the LM to specify the spatial relationship. Moreover, the phrase structure, such as an object noun after transitive verb and passive voice, appears to relate to the difference of connotation.

A-B-C Trajectory Cluster

On-the-other-side-of (2A)

The sense of the A-B-C trajectory is theoretically based on the mental representation prompted by the sentence *The cat jumped over the wall* (Figure 5.9 below). This reminds us of the scene, such that (A) the cat, the TR, diagonally jumps off the ground; it passes above and across the wall, the LM (B); and the cat makes a landing from the air onto the ground (C). Tyler and Evans (2003a) define the sequence of the movement as the A-B-C trajectory and argue that the mental representation of it is associated with the derived senses, such as 'on-the-other-side-of', 'above-and-beyond', 'completion', 'transfer' and 'temporal'. This mental representation appears to be identical with Dewell's (1994) central schema of *over* (Figure 5.2 above); however, Tyler and Evans do not regard it as a central schema possibly related to all the derived senses; they set a limit to the association of the A-B-C trajectory schema with particular senses.

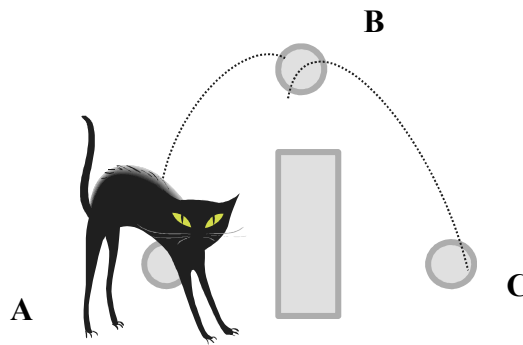

Figure 5.9 *The cat jumped over the wall* (Tyler and Evans, 2003a)

The sense of *on-the-other-side-of* is one of the senses in the A-B-C trajectory cluster (Figure 5.6 above). The image schema transformation of the end-point focus is likely to give rise to this sense. That is to say, the *on-the-other-side-of* sense originates from the path movement and, as a result of foregrounding the end point of the movement (Tyler and Evans, 2003a), *over* in this sense comes to express the result in which the TR reaches a destination, the LM. The verbs found in the sentences of the sense are as follows:

BE, CLATTER, CLIMB, COME, CROSS, DIRECT, ESTABLISH, GET, GO, LEAP, ORIGINATE, PASS,
PEEP, REACH, SPEED, STUMBLE, TAKE, TRANSMIT, TRAVEL, WALK

Of these verbs, several clearly indicate a path schema, movement from one place to another, such as CLIMB, CROSS, GO, LEAP, PASS, TRAVEL and WALK. But an impediment in the course of travelling seems to be highlighted by STUMBLE. As noted earlier, Tyler and Evans' supposition of the *on-the-other-side-of* sense is based on highlighting a destination at which the TR intends to arrive. While (25) and (26) seem to indicate a destination implicitly, namely the place behind the wall, (27) is unlikely to show the destination in the context because of highlighting an impediment to the crossing. Therefore, this may imply that foregrounding the halfway course of the path is reflected in the *on-the-other-side-of* sense (cf. the 'profiled central region' in Dewell, 1994: 355).

- (25) My nails are growing longer and I've developed a new habit of climbing over the garden walls at the back of the house. <W1B-001 #070>
- (26) I was just on the entrance to the pub and OK leapt over the wall. <S1A-047 #267>
- (27) When Mundy stumbled over a chair and fell he was attacked by Marshall "in a frenzy" and stabbed and slashed on the left leg. <W2C-012 #084:4>

The on-the-other-side-of sense is assumed to be an independent sense, largely because it is assumed to be unable to derive from the proto scene, the TR located above in the sphere of the LM (Tyler and Evans 2003a, 2003b). As in *John lives over the hill* (Tyler and Evans 2003a: 82), the focus of the speaker tends to shift to the place behind the TR (hill), rather than the middle of the path. This sense in the data is observed nowhere except the two sentences containing BE *over* ((28) and (29)). Only certain verbs referring to a static state may lead to the sense of end-point focus. In conclusion, the findings from (25) to (29) are likely to account for the fact that the verb to a certain extent integrates with *over* in terms of the interpretation of the sentence and the establishment of a particular spatial configuration of the two entities involved.

- (28) The flat was over a disused garage. <2F-006 #024>
- (29) Uhm, you see, of course, the detail here of, the of of of, the vault that's over the main sanctuary area,... <S2A-060 #066>

The idiom of *LOOK/CHECK over shoulder* implies that the focus of attention is not given to the noun after *over*, 'shoulder', rather something for which the speaker feels fear, such as 'threat' and 'danger' as in (30) and (31). Similar to BE *over* earlier, this expression implicitly emphasises a non-physical entity behind the TR; that is, it refers to a tense atmosphere behind someone's shoulder.

- (30) He looks over his shoulder to make sure there's no threat to his position in the

first three. <S2A-008 #193>

- (31) Steve checks over his, uh, shoulder to see if there are any dangers. <S2A-006 #112>

GET *over* does not seem to correspond to the sense mentioned so far. This phrasal verb means overcoming hardship and difficulties, which are not physical entities. To my knowledge, there has been no research on *over* senses which discuss GET *over*. I classified this use into the on-the-other-side-of group of senses, since the phrase seems to be associated with the scene as though a person were climbing over adversity and eventually gets through it; however, there still remains some doubt whether it should be categorized into the on-the-other-side-of group of senses. Interestingly, this interpretation occurs specifically in the case that a human being is the TR and an abstract object, such as a matter causing distress ((32) and (33)) is the LM. It could thus be argued that the overcome sense linked to GET *over* may be a derivative interpretation from the on-the-other-side-of sense.

- (32) I was getting over it [jaundice]. <S1A-028 #054>

- (33) Oh yes, well, you know, you must get over it [death of David] as best as you can. <S1A-049 #017>

	with prepositional complement	without prepositional complement
Verb + <i>over</i>	<i>be, come, check, cross, clatter, climb, get, go, get, hand, leap, live, look, originate, pass, peep, see, speed, stare, stumble, travel, walk</i>	<i>bowl, come, go, push, rush, wander, pull, send, take</i>
Verb + O + <i>over</i>	<i>bring, express, get, have, leave, map, see, get, invite, reach, take</i>	<i>carry, pop</i>
BE V-ed + <i>over</i>	<i>marry, direct, establish, transmit, run</i>	<i>get, invite, push, send, take</i>

Table 5.3 Verbs and sentence structures in the sense of on-the-other-side-of

As has been seen in the account of proto scene, the verbs co-occurring with the *over* of the on-the-other-side-of sense are classified according to the sentence structure. Obviously, many verbs are used without a noun phrase following the preposition unlike those in the proto scene sense discussed above. The verbs followed by *over* alone without a prepositional complement denote a movement from one place to another, such as *CARRY, COME, GO, PUSH, PULL, SEND, and TAKE*. This might be largely because the on-the-other-side-of sense denotes path movement which does not necessarily require the involvement of TR and LM. In other words, the absence of LM, which is materialised as adverbial *over*, seems unlikely to affect the description of path movement (Tyler and Evans, 2001, 2003a). As a result, such an identical verb as *COME* used with *over* is expressed with a noun phrase ((34) and (35)) and occasionally without it when the path movement is specially foregrounded ((36) and (37)).

(34) So **he** came over here and he got the cheque off me. <S1A-008 #275>

(35) Use a bag that will go over **your shoulder**, or wear a small one across your

body under a jacket or coat or a shoulder bag with a short strong strap and good fastenings. <W2D-009 #073>

(36) This guy called Randy from California who came over. <S1A-078 #228>

(37) But he said, said that he had started to go over. <S1B-068 #094>

So far the three candidates for the central schemata of *over* have been discussed: above and across (Figure 5.1); path (Figure 5.2); and static locative schema (Figure 5.3). In relation to the co-occurring verbs with *over*, the path schema seems the most likely to be productive in terms of the interpretation of spatial configuration. Compared to other languages, English verbs are unlikely to bear the meaning of path (Levinson and Wilkins, 2006; Talmy, 2000). For instance, *moved down* in English is composed of a verb and particle denoting a path downward, while with the Spanish equivalent verb *bajar*, the path meaning is packaged in the one word alone. This may imply that some verbs in English are unlikely to independently denote path sense. Nevertheless, admittedly one verb packaging and that of verb plus particle are both available as in the English *go in* vs. *enter* (Levinson and Wilkins, 2006). The possibility still remains that both verb and *over* are involved in the interpretation of configuration, largely because the integration of the schemata of verb and preposition may give rise to a particular trajectory of path movement. Therefore, further analysis of the central schema is due.

Above-and-beyond (Excess I) (2B)

Over in the above-and-beyond sense belongs to the A-B-C trajectory cluster and the sense differs from that of on-the-other-side-of, because in this case what is highlighted is excess over a limit and also the end-point after movement. Take (38) for instance: the speaker specifies the destination, *his head*, at which the agent, *it* [the ball], is expected to arrive, but in fact it goes over this point, contrary to expectations. In the on-the-other-side-of sense, the

prepositional complement after *over* indicates a place to move with the result that the agent remains there after the movement. The agent may not arrive at the destination in the above-and-beyond sense; rather, it happens to remain at a different place where the speaker does not expect it to move. Accordingly, *over* in the above-and-beyond sense can be assumed to require a noun phrase which indicates a contemplated destination; in other words, one could speculate that the instances of this sense would fall into the category which has a prepositional complement following the preposition.

- (38) It [the ball] goes over his head, takes a knock off Kenny, Sanson goes behind for a corner on the near side, ... <S2A-005 #169>

	with prepositional complement	without prepositional complement
Verb + <i>over</i>	<i>be, bounce, come, drift, fly, go, grow, loft, loop, pass, run</i>	
Verb + O + <i>over</i>	<i>loft</i>	
BE V-ed + <i>over</i>	<i>play</i>	
BE V-ed + O + <i>over</i>	<i>give</i>	

Table 5.4 Verbs and sentence structures in the above-and-beyond sense

The data in Table 5.4 above indicate that the presence of the prepositional complement after *over* identifies the linguistic features of the above-and-beyond sense. Physical marks of the expected destination, such as *point* and *length*, as well as abstract ones, such as *level* and *lap*, are found to follow *over* in this sense. Interestingly, many sports terms are also discovered, namely *baseline, bar, touchline, crossbar, goal keeper* and *touchline level*. This may be because many occasions in sports call for a judgement of whether something is

inside or outside of a line. Therefore, the excess of a target landmark may be frequently expressed in the given register. Still, part of the human body, *head*, turns out to be the most frequent PC in the sense, with 5 instances out of 18; this may imply the centrism of human beings in construal, on the basis of the principal argument of cognitive linguistics that we construe the world subjectively and our construal is reflected in our language.

According to Kreitzer (1997), an integrated configuration in the space sense of *over* is established by the amalgamation of the schemas of the co-occurring verb and the preposition (see 5.2.3 Sentential components of senses of *over*). If this is so, an identical verb plus *over* phrase should bear similar senses, but in fact it does not. Yet we have observed in fact that *COME over* and *GO over* are assigned to the above-and-beyond sense as well as the on-the-other-side-of sense discussed in the previous section. I would argue that an essential part is played by the prepositional complement in differentiating the two senses in the phrases. The PC of the above-and-beyond sense represents a breakpoint or separator line ((39) and (40)), while the on-the-other-side-of sense indicates a flat surface and is unlikely to function as a delimiter of excess. In conclusion, the world knowledge of the PC, e.g., the feature of separation, may help to interpret the subtly different senses of *COME over* and *GO over*.

(39) The number eight Robinson and Brian Rigney both came straight over the top of Leonard. <S2A-002 #075>

(40) That [the ball] too has gone high over the crossbar for another goal kick to the Soviet Union. <S2A-001 #041>

Completion (2C)

The sense of completion is unlikely to derive from a relationship between TR and LM, since the TR is always explicit but the LM rarely is – possibly, however, the LM could occasionally be deduced from context. In (41), the TR, *the fighting*, functions as a subject of completion, while a contrasted LM is obscure. The absence of the LM violates the central schema of *over*,

whereby the presence of both TR and LM is essential to the establishment of a spatial configuration.

- (41) The political damage may be limited if **the fighting** is over relatively quickly.
 <W2E-006 #084>

Similar to the account of the on-the-other-side of sense (2A), one could speculate that the completion sense is assigned alone by adverbial *over*; which highlights the path movement of TR. That is, a movement from beginning to end is foregrounded without a clear reference to the route. The corpus data illustrate that the verbs are not followed by a noun phrase, with the exception of one example with BE. Hence, the completion sense *over* is an adverb which is independent from a LM and conveys path schema.

	with prepositional complement	without prepositional complement
Verb + <i>over</i>		<i>be, close, end</i>
Verb + O + <i>over</i>		<i>get</i>

Table 5.5 Verbs and sentence structures in the completion sense

Not only verb but also noun phrase co-occurring *over* contribute to the interpretation of the completion sense. As was seen earlier, *GET over* can be interpreted as an overcoming sense (see page 124). Nevertheless, (42) is unlikely to denote the overcoming of a difficulty. The reason is that the noun phrase, *the story*, in between *get* and *over* encourages us to decode the sentence containing the combination as meaning completion⁷. Consequently, the noun phrase which follows *over* is likely to be involved in establishing the *over* senses, as has been

7 (42) can be decoded as ‘get [verb] + the story [object] + over [complement]’. As the *over* qualifies the object noun, it can be grammatically categorized as either adjective or adverb.

observed in the account of the above-and-beyond sense.

- (42) it's to get the story over, so you have mountain, mountain, mountain...
<S2B-059 #027>

Transfer (2D)

More than half of the instances of the transfer sense, 9 out of 19, are discovered to involve the verb *hand*. The verb outlines the environment of *over* which is associated with the sense of transfer; thus, the variation of sentence structures containing *HAND over* should be described. As in a model sentence provided by Tyler and Evans (2003a: 86): *Sally turned the keys to the office over to the janitor* [my underlining], a movable and handy entity is conceivably assumed to be delivered to a person. Yet the corpus in question sheds light on the fact that, as opposed to the model sentence, a person and the abstract entity also frequently occur ((43) and (44)). The phrase structure of (45) can be considered as a variation caused by particle movement (Biber *et al.*, 2002). Despite the alternation, a transferred entity is obvious in both types of the given structures.

HAND + O + over to someone

- (43) Yes, right. I'll hand you over to Giles for a second. <S1A-095 #177>

- (44) Unfortunately she handed the case over to Miss Jenkins. <S1B-063 #259>

HAND over + O + to someone

- (45) But I had to hand over the money to Bardell. <S1B-063 #104>

No transferred entity is referred to when 'authority' is metaphorically given to another person, as in (46). This implies that without mentioning authority the particular phrase, '*HAND over to someone*', could implicitly refer to the unwritten authority. The phrase is also idiomatically employed to mean that a speaker gives another a turn of speech, namely *We will, erm, if there is a suitable moment take a break in the middle of it, erm, but I'll now hand over to MX to start off* (Bank of English, my underlining). However, no instance of the idiom is found in my

data even in the speech register of the corpus analysed.

HAND over to someone

- (46) In order to assess the relative weight of such theories, he suggests, we must hand over to the analyst of probabilities. <W2A-007 #102>

Temporal (2E)

The temporal sense over is readily identified with a following noun phrase as in (47). *Christmas* refers metonymically to the period of time in which the agent is asked what s/he will be doing. A prepositional phrase of *over* and a temporal noun together convey a meaning equivalent to *during*.

- (47) What are you doing over Christmas? <S1A-040 #198>.

The data analysed show that three types of temporal noun frequently occur with the preposition of time sense: ‘countable unit of time’, ‘period of time’ and ‘event and activity’.

Countable unit of time:

*century(-ies), day(s), decades, hours, months, nights, seasons, summer, weekend, winter, year(s)*⁸

Unspecified period of time:

count, cycle, period, time

Event and activity:

Christmas, course, distance, lunch, meals

The first group of nouns is used to indicate a certain period of time in accordance with calendar days and months as in (48), while those of the second group do not specify a particular date but announce the length of time in the nouns, for example in (49) below. Obviously, *lunch* and *meals* are unlikely to be categorized as temporal nouns; however, they are metonymically assigned to the meaning of a period within which an action is performed

⁸ Day(s) and year(s) in brackets represent the fact that instances of singular and plural of the words are discovered in the data, while the nouns in the plural occur only in the plural form.

out while having food, as in (50).

- (48) So that what we've got here is a plot of the heat that is received averaged over the year, uhm, at a particular latitude. <S2A-043 #055>
- (49) ...and it'll be, it'll be, uh, produced over, autumn and Christmas period in ninety-two this next this year, and uhm...<S1A-058 #231>
- (50) ...and we were impressed by the calibre of the recent graduates which we met over lunch and afterwards. <W1B-026 #039>

Conceivably, a prepositional phrase containing the temporal nouns alone could be used to predict a temporal sense, namely, as in (47), the period of time *over Christmas* seems to be implied independently of the verb phrase, *are doing*. In order to examine the proposition, a number of frequent verbs with a temporal sense, most of which denote a sense of transition and increase, were compared with the given nouns in terms of the likelihood of collocation with *over*.

VERB	MI	T	NOUN	MI	T
<i>average</i> (1)	7.72	17.86	<i>decades</i> (2)	8.05	25.34
<i>change</i> (1)	8.65	37.85	<i>hours</i> (2)	8.80	29.16
<i>develop</i> (1)	8.86	23.44	<i>months</i> (2)	7.27	39.13
<i>double</i> (1)	8.67	21.49	<i>year</i> (3)	8.56	73.52
<i>increase</i> (1)	8.12	28.06	<i>years</i> (2)	8.58	141.34
<i>occur</i> (1)	9.03	16.79	<i>cycle</i> (3)	8.46	7.98
<i>produce</i> (1)	8.00	12.04	<i>time</i> (1)	8.54	67.41
<i>reduce</i> (2)	7.85	9.55	<i>period</i> (2)	8.19	53.76
<i>rise</i> (1)	8.03	24.36	<i>Christmas</i> (1)	8.84	27.87
			<i>lunch</i> (1)	9.00	22.12
			<i>meals</i> (1)	7.84	3.59

Table 5.6 MI and t-score of co-occurring verbs and nouns with temporal *over*

Table 5.6 shows the MI scores and t-scores of the verbs and the nouns co-occurring with *over* obtained from the Bank of English. By definition, the former statistical index represents ‘strength of collocation’ in relation to *over* on the one hand, and the latter represents ‘certainty

of collocation', on the other (Hunston, 2002: 73). The result demonstrates that, although the MI scores do not differ in the verbs and nouns, several nouns, such as *year*, *years*, *time* and *period*, surpass them in the t-score⁹. It could be implied as a result that the verbs and nouns may contribute equally to convey the temporal sense of *over* in terms of frequency; however the given nouns which characterise temporal features are likely to co-occur more frequently than the verbs. Kreitzer (1997) claims that the configuration of *over* is inferred from the integration of the schemas of verb and preposition, but in fact the noun possibly also contributes to the interpretation of the configuration.

Covering (3)

The sense of covering is explained by reference to a setting, as in (51). The TR, *tablecloth*, is located above or upon the LM, *table*, and at the same time the TR conceals the existence of an entity below, out of sight. To the extent that the TR screens the LM, spatial configuration can be applied to a topological relation in which they are not located above and below. As implied in (52), if the configuration is clearly described, the covering thing can be placed on the wall – for example, a poster on a notice board – as well as on the ceiling in such a way as to prevent water from dripping through (Tyler and Evans, 2003a, 2003b).

(51) The tablecloth is over the table. (Tyler and Evans, 2003a: 90)

(52) You could've sheeted it over or something. <S2A-069 #164>

The concealing function was considered to determine the covering sense of *over*. Yet the analysed data provide another insight into the sense. Examples (53) and (54) illustrate that concealing is unlikely to outweigh another feature of the sense, namely 'distributive location' (Dewell, 2007; Jackendoff, 1990; Lakoff, 1987). The attempt of the TRs, *sanctuaries* and

⁹ Statistically, the t-score is estimated by the subtraction of expected frequency from the observed frequency and then being divided by the standard deviation. The MI score is the observed frequency divided by the expected frequency and then converted to a binary logarithm (Hunston, 2002).

cannabis, is not to hide the land below them, since obviously the scattered entities are incapable of concealing the LM. Human construal is reflected in this type of transformation which shifts from scattered points towards a planar covering. As discussed above (see section 5.2.2), the transformation of schemas from multiplex into mass is reflected in a number of aspects of language (Lakoff, 1987).

- (53) ...many sanctuaries that at that point had existed all over the country and the free access,.. <S1B-001 #004>
- (54) He would say that if it [*cannabis*] was grown over here it would be lighter in colour. <S2A-068 #100>

Likewise, an image schema transformation from multiplex into mass is also observed in the movement throughout making a path, a ‘multiplex path’ (Lakoff, 1987: 429). The TR is not located in an unrelated manner; rather, the passing points are conceived to construct a pathway strung between them. Such a tight track of movement is construed as if it were a planar cover. The unrestricted movement of the TR within a sphere of the LM can be discerned in (55) and (56):

- (55) He’s going all round Italy Austria Switzerland all over the place inter rail, so. <S1A-081 #274>
- (56) ...and ensure that our children’s children will be able to see a barn owl silent as a cloud, drifting over the fields of our countryside. <S2B-031 #114>

‘Lacunal covering’, which should be distinguished from the concealing sense, indicates that the TR veils the LM more densely than the covering of distributive location and multiplex path; however, there still remain some gaps in the cover, which is unlikely to have been aimed to conceal the entity underneath ((57)). Surfaces loosely covered by the TRs are merely highlighted by multi-directional covering as honey spreads over a pancake (Dewell, 1994).

- (57) **Mulching materials such as straw or hay, or sheets of black polythene**, can also be spread over the soil surface to prevent weeds from competing with crops. <W2B-027 #117>

As discussed above, four types of covering should be taken into account to describe the covering sense of *over*. As the schema of covering shifts from points to planar, the transformation of construal takes place from multiplex to mass at the same time. Scattered points of distributive location are not recognised as cover when a speaker looks at them at close range; however, when looked down on from a distance, the points are construed as a collective planar formed by dots (Dewell, 1994; Lakoff, 1987).

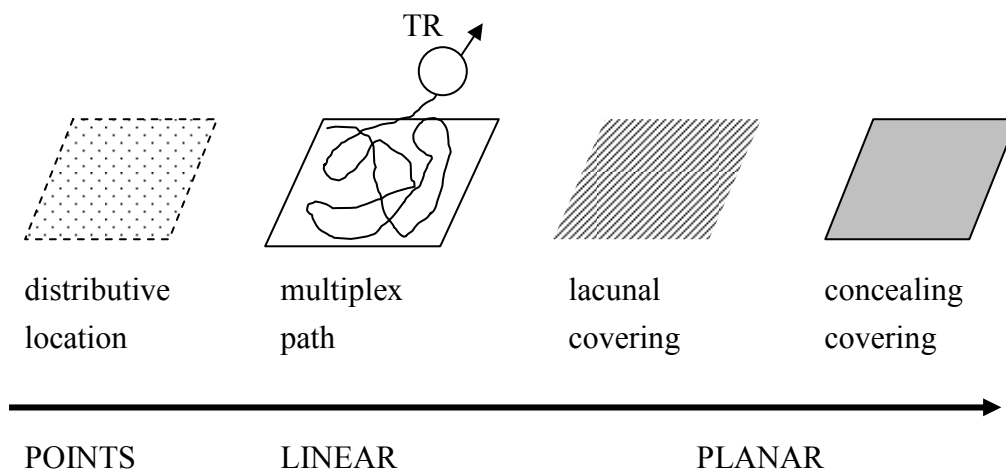

Figure 5.10 Geometric transition of covering sense, partly adapted from Lakoff (1987)

The verbs in the covering sense are classified into the four sub-categories shown in Table 5.7 below. The verbs in the distributive location are those which signify the action of placing, such as *DEPOSIT* and *DISPLAY*, as well as causing incidents, such as *CAUSE*, *DESTROY* and *HAPPEN*. The multiplex path, for its part, is expressed with the verbs which are associated with such movement as *DRIFT*, *GALLIVANT*, *GO* and *MOVE*. Lacunal and concealing covering occurs with different types of verb, such that those which in their concealing covering recall

the covering attributes which derive from an entity of the noun form, such as *COVER*, *CUP*, *GLOSS*, *PAPER* and *SHEET*. It could be concluded as a result that the verbs to a large extent correspond to the sub-categorized covering senses. If this is the case, do the other components in the clause harmonise with the meaning of the verbs in the given coverings?

distributive location	<i>cause, deposit, destroy, detect, develop, display, disintegrate, exist, grow, happen, set, split, use</i>
multiplex path	<i>arrive, drift, gallivant, go, move,</i>
lacunal covering	<i>achieve, close, froze, hit, record, sprawl, spread</i>
concealing covering	<i>bundle, cover, cup, gloss, paper, sheet, slide</i>

Table 5.7 Covering senses and the co-occurring verbs

First, Table 5.8 below shows that concrete objects, such as *bomb* and *sanctuaries*, often precede the verbs and at the same time the nouns referring to places which follow, for instance, *Scandinavia*, *island*, *area* and *country*. This in turn implies that distributive location covering is represented by indicating that non-intentional entities are situated in a place. Thus, the sequence of a concrete object followed by a verb of action or cause, and a prepositional phrase, *over*, plus a place, can be considered to be the phrasal frame of the distributive location covering. Therefore, in terms of the covering sense the combination of the TR and LM could predict the *over sense* of distributive location covering.

ICE sentence code	TR	verb	LM
W 2C 029 008	smoke	<i>cause</i> ...havoc	over a ... large part of planet
W 2A 030 080	mach of sulphur dioxide	is eventually <i>deposited</i>	over Scandinavia
W 2C 001 043	bomb	<i>destroyed</i>	over Lockerbie
S 2B 001 072	traces of chemical	had been <i>detected</i>	over a wide area
S 2A 024 054	it [Ionic]	's <i>developed</i>	over
S 2A 024 065	Ionic	<i>developing</i>	over there
W 2B 028 112	images of the birds	are <i>displayed</i>	all over the island
S 1A 088 152	plutonium	is going to <i>disintegrate</i>	over a ... large area of...
S 1B 001 004	sanctuaries that	...had <i>existed</i>	all over the country
S 2A 058 154	epidermal keratinocytes	start to <i>grow</i>	over
S 2A 068 100	it [cannabis]	was <i>grown</i>	over here
S 2B 013 047	actually what	's <i>happened</i>	over the Gulf
S 2B 029 078	[we] now	<i>set</i>	over commands
S 2A 034 058	these [results]	can be <i>split</i>	over a complete network
W 1A 006 050	these forms	<i>use</i> symbols	over certain points

Table 5.8 TR and LM in distributive location covering senses

Second, Table 5.9 below illustrates that the features of the co-occurring subject noun (trajector) and the noun phrase following the preposition (landmark) closely relate to the path covering sense. Unlike the distributive location, the nouns referring to human beings, such as *thousands*, *children* and personal pronouns, appear overwhelmingly as trajector and places in which a flat surface is highlighted as a feature, such as *fields*, *surface* and *world*, are remarkably found as landmarks. As a result, a distinctive combination of trajectory and landmark emerges from the mental representation that people move around on the surface of the ground.

ICE sentence code	TR	verb	LM
S 2B 027 110	thousands [people]	<i>arrive</i> from all	over Europe
S 2B 031 114	a barn owl	<i>drifting</i>	over the fields of... country side
W 2F 013 041	she	went <i>gallivanting</i> all	over the world
S 1A 081 274	He	's <i>going</i> all	over the place inter rail
W 2A 036 034	the probe	has <i>moved</i>	over the... surface of interest
S 2A 027 016	this [superstition]	<i>went</i> all	over the world

Table 5.9 TR and LM in multiplex path covering senses

Third, in a similar manner to the multiplex path, human beings and personal pronouns are overrepresented as trajectors, while abstract entities, such as *consequences*, *thoughts*, *parapraxes*, *theories* and *cracks*, as landmarks, occupy a position after *over*.

ICE sentence code	TR	verb	LM
S 2A 014 159	He	's <i>bundled</i>	<i>over</i>
S 1B 069 184	a void	which was <i>covered</i>	<i>over</i>
W 2F 012 002	[policemen]	<i>cupped</i> his hand	<i>over</i> his ear
S 1B 031 066	[people]	to <i>gloss</i>	<i>over</i> the real consequences
W 2B 001 120	I	was tempted to <i>gloss</i>	<i>over</i> certain thoughts
S 1A 090 073	He	<i>glossed</i>	<i>over</i> that
W 2A 002 062	he	<i>glosses</i>	<i>over</i> the parapaxes
W 1A 004 079	[I]	<i>glossing</i>	<i>over</i> the theories
S 2B 006 041	for the Tories	to <i>paper</i>	<i>over</i> the cracks
S 2A 069 164	you	could've <i>sheeted</i> it	<i>over</i>
S 2A 041 002	for copper	<i>sliding</i>	<i>over</i> copper

Table 5.10 TR and LM in concealing covering

The concealing covering sense is used in a metaphorical manner which highlights the function of shrouding facts and thoughts, rather than physically obscuring an entity, as in (58) below. The landmark of (59) seems to be a tangible entity, but it refers in fact to metaphorical cracks.

Thus, disagreeing with Kreitzer's (1997) claim that the integration of verb and *over* schemata determines the interpretation of movement, it appears that trajector and landmark contribute to the interpretation of a metaphorical configuration derived from a spatial configuration. Consequently, not only verbs but also nouns as trajectors and landmarks need to be analysed for the task of describing the senses of *over*.

- (58) In case I was tempted to gloss over certain thoughts, I decided to share the diary which had helped me admit to myself what I was now admitting to the listeners. <W2B-001 #120>
- (59) The Labour leader Neil Kinnock will argue in his speech that Mrs Thatcher's not fit to govern and that challenge or no challenge to her leadership it's impossible for the Tories to paper over the cracks.. <S2B-006 #041>

Examining (4)

Over conveys the examining sense in some particular contexts. Verbs relevant to vision turn out to be diffused in the examining sense: *CAST [eyes], [eyes] DART, LOOK, READ, and STARE* ((60)-(62)). The frequent use of visual verbs may stem from the fact that we examine a case by means of eyesight. Here we can exemplify that our kinaesthetic experiences are reflected in language.

- (60) I do not think I have changed the meaning at all, but perhaps it would be as well for [unclear-word] to cast a final eye over it anyway. <W2A-030 #008>
- (61) He says, well, if you think God doesn't love you, you only need look over the border to Edom... <S2A-036 #020>
- (62) I'm just going to try and get myself a better vantage point because I'm sort of staring over the side of a building and all I can see is bricks at the moment <S2A-008 #104>

However, *GO over*, which seems irrelevant to visual sensation, is also employed frequently in this sense ((63) and (64)). This may be largely because the examining sense derives from a metaphor that GOING IS SEEING¹⁰: that is, if you go through a path, then you will know what it is like.

- (63) And then if you go over that again, you've then got find by date results reduced which is another pair of facing pages, <S1B-017 #157>
- (64) Now, Tony, we'll just go over the basic procedures to start your bike before you sit on it. <S2A-054 #053>

Likewise in the account of concealing covering which was discussed in the previous section, other components of the clause apart from the verb and *over* also provide insight into the examining sense. Personal pronouns, such as *I*, *you*, *we* and *me*, as trajectory are overwhelmed, while at the same time the pronouns of anaphoric reference, such as *it*, *that*, *this* and *them*, as landmark, frequently appear to follow *over* (Table 5.11 below). This might imply that the examining sense is often employed in a situation where the speaker verbalises it in order to instruct the listener, occasionally including the speaker him/herself. This empirical proposition is likely to be endorsed by the fact that a large number of instances occur in the spoken register – S of the ICE sentence code in Table 5.11 below represents spoken; and the verbs follow either modals, such as *will* and *need*, or auxiliary phrases, such as *want to* and

¹⁰ The concept of metaphor is represented in small capitals.

let's, whereby an action is to be carried out.

ICE setence code	TR	verb	LM
W 2A 030 008 for	him	to cast	over eye it [agreement]
S 1A 045 099 their	eyes	dart	over all over the hall
S 1B 017 157 if	you	go	over that [analysis]
S 1B 064 139 let	me	go	over this
S 2A 038 027 while	I	go	over them [definitions]
S 2A 054 053	we just	'll go	over the basic procedures
S 2A 028 086	[you]	Having got	over this [message]
S 2A 036 020	you	need look	over the border to Edom
W 1B 003 166	I	read your letter	over
S 2A 008 104	I	'm staring	over the side of a building
W 2F 004 037	I	went	over it again

Table 5.11 TR and LM in examining sense

In the light of the analysis of this section, it could be concluded that other components of the clause, in particular the nouns of trajector and landmark, could provide a semantic account of the examining sense.

Focus-of-attention (4A)

The focus-of-attention sense of *over* is accounted for by the fact that an equivalent preposition *about* can replace it. It follows that the abundance of the verbs denoting speech and talk, such as *ASSERT*, *COMPROMISE*, *EXPRESS*, *NEGOTIATE* and *TALK*, which closely relate to the context of speech acts, are often observed in instances of this sense ((65)-(67)).

- (65) It might help to clear my mind if I could talk it over with someone. <W2F-011 #030>
- (66) It's clear the coalition is not in a mood to negotiate over its demands with the main issues expected to be resolved tomorrow. <S2B-004 #041>
- (67) Interest in possible damage to the ozone layer was first raised in the early 1970s, when atmospheric chemists expressed concern over the possible damaging effects of CFCs ... in the atmosphere. <W2B-030 #036>

Despite the fact that these verbs of speech and talk seem neutral in terms of context, the verbs which express feeling followed by *over* in the focus-of-attention sense look likely to

be relevant to a negative context: *BROOD*, *FIGHT*, *FUSS*, *GRIEVE* and *LINGER*¹¹.

- (68) But she broods over Nellie's earlier insinuations about Caroline's destiny. <W2B-009 #104>
- (69) Like Isis I cannot but grieve over the dismembered body of my mother and try best I can to put back together the parts of her,... <W1A-008 #005>.

The evaluative and pragmatic meaning of the context is inferred by sets of small phrases, rather than one word alone (Sinclair, 2003, 2004). The concept, 'semantic prosody', which accounts for the semantic interrelationship of phrases offering a specific context, helps to provide a clear account of the focus-attention sense. The co-occurring subject nouns and those following *over* draw such negative inferences as disagreement and difficulty: for instance, *charges*, *conflict*, *confusion*, *controversy*, *demand*, *disagreement*, *incident*, *insinuation*, *issue*, *problem*, *seizure*, and *rift*. In addition to the given verbs and *over*, the nouns referring to a problematic setting seem to be involved in establishing such negative contexts.

- (70) These infrequent disagreements tended to arise over charges by me of dishonesty or untruthfulness in a politician. <W2B-015 #052>
- (71) The conflict could have just as well been over the seizure and control of Imperial estates, granaries and potteries ... <W1A-001 #030>
- (72) That's right and my confusion was over the question. <S1B-062 #094>

Co-occurring nouns with the preposition can differentiate the polysemy of a phrasal verb. *Hang over* has been discussed in the account of the proto scene (see page 124). In the above-located sense, the phrasal verb means that a 'place' is physically overlaid, while that of example (73) is metaphorically interpreted to denote *about*, largely because 'demand' cannot be physically underneath. Thus, the nature of co-occurring nouns with *over*, that is, to have

¹¹ These verbs correspond to some of the instances of the 'grieve' group provided by the grammar pattern of *V over n* (Francis *et al.*, 1996: 236).

trajector and landmark contribute to a certain extent to the interpretation of the polysemous phrasal verb containing *over*.

- (73) According to the spokesman, a large question mark also hangs over the Iraqi demand for reciprocity. <S2B-004 #023>

Up cluster

The semantic network of *over* illustrates that the up cluster consists of the four subcategory senses which share its semantic features (see Figure 5.6). Whereas the other cluster of *over* senses, the A-B-C trajectory cluster, represents horizontally arced movement, the senses in the up cluster closely relate to vertical augmentation (Tyler and Evans, 2003a). Based on experiences thorough living, we learn that as the height of an entity gets taller, its quantity increases at the same time. For example, imagine cardboard boxes, with their content increasing as they are accumulated. In the same manner, we recognise that the entity in the upper position is semantically associated with increase, excess, control and preference.

More (5A)

The analysis of this section will examine whether the instances of the more sense of *over* show a distinctive distribution of co-occurring verbs and TR/LM nouns. The results indicate that verbs denoting amount and numbers as LM appear to occur frequently.

The *over* of this sense can be paraphrased with ‘more than’ and tends to occur with a following noun phrase of numbers. The mental representation of the more sense derives from an image that one entity (TR) is higher than the other (LM) which is referred to a point of reference (Figure 5.11 below). More sense is used to contrast one thing with another in terms of excess. Without a numerical benchmark the relation of ‘the exceeding’ (TR) and ‘the exceeded’ (LM) cannot be established. As shown in Table 5.12 below, figures and percentage are frequently found in the landmark column ((74) and (75)). As a result, the distinctive LMs

which represent a numerical benchmark are likely to be closely associated with the *over* of more sense.

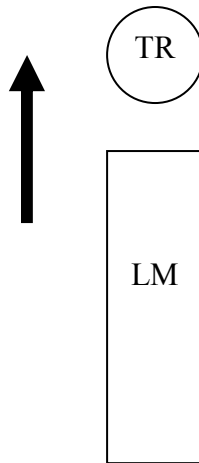

Figure 5.11 The mental representation of more sense (Tyler and Evans, 2003a: 98)

- (74) If **you** are **over** **age 60**, or will be 60 in the current tax year, and you are unemployed you may claim Unemployment Benefit as usual. <W2D-004 #089>
- (75) At home **Hertfordshire County Council** says twenty teaching jobs will be cut in order to save **over** **four hundred and fifty thousand pounds**. <S2B -015 #076>

ICE sentence code	TR	verb	LM
W 1A 013 023	they [China and India]	would account for	over a half of world trade
W 2C 004 079	which offer	amounts to just	over 56% of the share
W 2D 002 039	if you	are	over pension age
W 2D 004 058	whose profits or gains	are	over a certain amount
W 2D 004 089	you	are	over age 60
S 2A 039 051	[Citizen's Advice Bureaux]	to deal with	over eight million cases
S 2B 027 119	The pilgrimage	was established	over a 1000 years ago
S 2A 039 052	courts	handle	over 97%
W 2B 012 113	unemployment	had increased	over 400,000 in 4 months
W 2B 014 018	traffic	increased by	over 27%
S 1A 027 262	She	is	over seventy
W 2B 023 033	the patient	is	over the age of twenty
S 2B 015 076	[Council]	in order to save	over 450,000 pounds
S 1B 056 018	if patients	suffer heart attacks	over the age of 70
S 1A 095 084	they [sixteen overs]	were	over eight
S 1A 096 197	they [seven hundred people]	were	over that
W 2D 004 034	if you	were	over 16

Table 5.12 TR and LM in the more sense

Quantity as well as number seems to be a suitable candidate for LM in this sense. *Amount* generally implies an uncertain quantity which cannot indicate a figure. In (76), the quantity unit is used as a threshold of profits to classify class contributions. Table 5.12 shown above seems to indicate that *age* is a non-numeric LM too, but in fact the word is followed by a phrase indicating a particular number, in the case of (77) pension age 65 or 70. In turn, number, *amount* and *age* are the frequent LMs of the more sense.

- (76) Self-employed people whose profits or gains are over a certain amount may have to pay Class 4 contributions as well as Class 2 contributions. <W2D-004 #058>
- (77) You cannot get Unemployment Benefit: after the age of 65 if you are a woman, or 70 if you are a man, or if you are over pension age and the pension you will get... <W2D-002 #039>

Verbs denoting quantity, namely *ACCOUNT for*, *AMOUNT*, *AVERAGE* and *INCREASE*, occupy the instances of the more sense. Some of the verbs are also frequently found in those of the temporal sense (2E): *So that what we've got here is a plot of the heat that is received averaged over the year, uhm, at a particular latitude* <S2A-043 #055> and *uh, spending on training has increased over the last four years by sixty per cent in real terms at a time...* <S1B-059 #025>. Suppose that the senses of *over* are generated from the combination of verb and *over*: *AVERAGE over* and *INCREASE over* should be interpreted in the one sense of either temporal or more. However, the nature of the LM allows us to differentiate the two senses. The LM of the temporal sense, *over the year*, indicates a period of time in which a change takes place, whereas that of the more sense shows amount of change, *over 12 minutes*. Given that world knowledge is assumed to be an important factor of interpretation (Tyler and Evans, 2003a), it could be more specific to argue that knowledge of the LM contributes to differentiating the two senses. *Increase* and *over* also can be interpreted in the same sense,

however the presence of *by* highlights the nature of amount of change, rather than period of time. Again, not only the verb, but also the LM, is likely to contribute to a large extent to the interpretation of the *over* senses.

- (78) The size distribution by volume measured by the FSSP averaged over 12 minutes in the dense haze is shown in Fig. 6,... <W2A-029 072>
- (79) Unemployment had increased by over 400,000 in the last four months alone. <W2B-012 #113>

Such verbs denoting quantity as *ACCOUNT for*, *AMOUNT*, *AVERAGE* and *INCREASE*, also retain a distinctive feature of the co-occurring subject. Non-human subjects, such as *offer*, *size distribution*, *unemployment* and *traffic*, tend to occur with verbs followed by a prepositional complement of number or unit. Cognitive linguists argue that the two entities whose configuration is established by a preposition are defined as trajector (TR) and landmark (LM) individually (Langacker, 1987; Ungerer and Schmid, 2006). In this case, the non-human subject is the trajector and the number or unit prepositional complement is the landmark. The reason why the distinctive combination of TR and LM is frequent can be understood by examining the nature of the TR and LM. Non-human entities can be counted, averaged or increased and the amount can be represented by numbers. As a result, a pattern containing the more sense *over* is discovered, as shown in Figure 5.12 below by analysing the co-occurring subject and prepositional complement which relate in terms of TR and LM configuration.

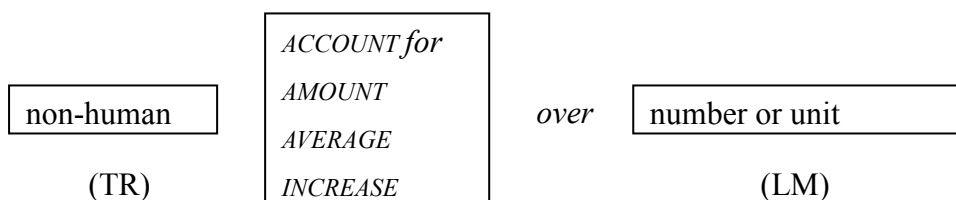

Figure 5.12 Clause pattern of the more sense of *over* with quantity verbs

Likewise, *age* also appears in a particular clause pattern. Age is mainly applied to humans and indicates how old they are. Therefore, it is not surprising to find it frequent that a human being is the TR and the verb is BE followed by *over age* (Figure 5.13 below). In other words, the TR and LM combination of human being and age is likely to occur frequently with BE *over*. As a consequence, I would argue that, given that the verb is related to the senses of preposition, the co-occurring nouns also contribute to them to a certain extent, due to the fact that the particular combination of TR and LM nouns is found in a particular sense.

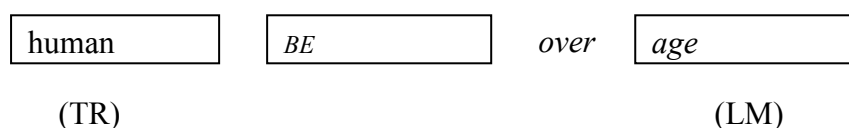

Figure 5.13 Clause pattern of the more sense of *over* with *be* and *over*

Over-and-above (Excess II) (5.A.1)

The over-and-above sense is categorized as one of the excess senses: the other is the above-and-beyond sense (Excess I) in the A-B-C trajectory cluster. As the over-and-above sense belongs to the up cluster, the mental representation which is reflected in the sense is different from that of the above-and-beyond sense. If so, does the different mental representation of the senses attract a different TR and LM? In other words, is there any difference in terms of the co-occurring subject and prepositional complement in the two different excess senses and belonging clusters? In this section, the analysis of the instances of the over-and-above sense will suggest a difference of verb, TR and LM between the excess of the A-B-C trajectory cluster (Excess I) and that of the up cluster (Excess II).

The above-and-beyond sense derives from the mental representation of the A-B-C trajectory. A TR goes to a destination further than where an LM is located; the trajectory is described rather horizontally. On the other hand, the over-and-above sense is associated with a

concept that the TR in a container increases upward and vertically, and then crosses over the boundary of the LM. As in (80), the TR, *potatoes*, metonymically refers to the boiling water and *over* indicates that the TR spills over the outside of the pan which has the potatoes inside. The movement of the TR is vertically upward. By contrast, the TR of (81) moves horizontally as bullets fly across the air. The movement of the two different excesses is associated with horizontal overrun (Excess I) and vertical overflow (Excess II) respectively.

(80) I'm just stood there watching the potatoes boil over. <S1A-016 #337>

(81) ...the bullets were going over our head very close to our head because he ran right past us,.. <S2A-050 #160>

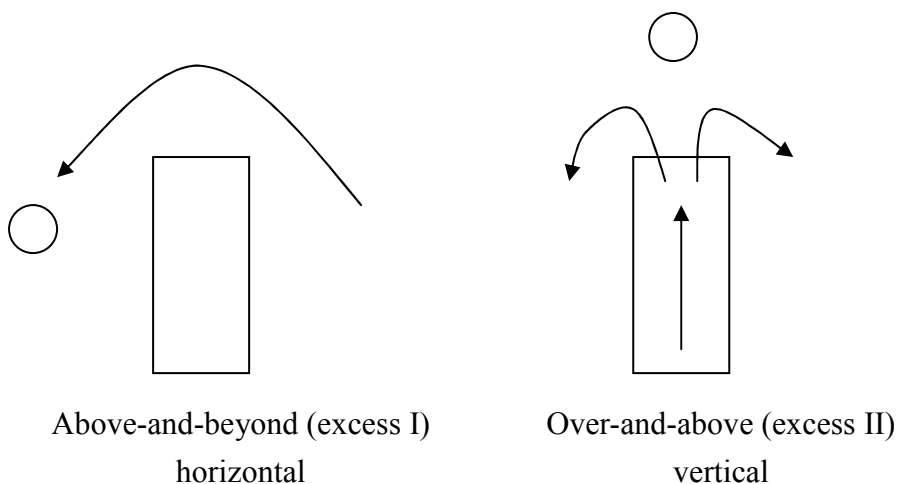

Figure 5.14 The mental representation of the excess senses

The verbs which co-occur with the *over* of the over-and-above sense show its nature of vertical overflow: *BOIL*, *POUR* and *SPILL* (Table 5.13 below). In particular, the nature of overflow of *SPILL* is highlighted by a following phrase of *into the interior*, as in (82). They provide a clear contrast with the verbs of the other excess sense, which convey a horizontal movement such as *GO*, *LOOP* and *PASS*. Hence, it could be argued that particular verbs occur in accordance with the sense of *over*.

(82) And **the big numbers** spill over into the interior as well. <S2A-055 #092>

ICE sentence code	TR	verb	LM
W 2F 001 111	Cassie	'd be	over the moon
S 1A 016 337 watching the	potatoes	boil	over
S 2B 027 142 The	excitement	boils	over
S 2A 003 232	England	charge	over the top
S 2A 016 060	Conichev	goes	over the top of him
W 2B 008 088	Bernstein	rather goes	over the top
S 1A 087 258	that	's going	over the top a little bit
S 2A 017 190	it [header]	's knocked	over the top though
S 2A 002 200 The whole of	Ireland	pour	over the top there
S 2A 055 092 the big	numbers	spill	over into the interior
W 2A 017 069 psycho-political game	which	spills	over into a spiral of images

Table 5.13 TR and LM of the over-and-above sense (Excess II)

The over-and-above sense appears to be followed frequently by a distinctive noun – *top* as part of phrase ‘*over the top*’. The landmark *top* is unlikely to be a physical boundary; it is rather an imaginary boundary which the speaker considers as a limit of acceptance and toleration. For instance, (83) seems to indicate that an action, *that*, might be unacceptable because it is beyond capacity. Similarly, (84) suggests that Bernstein’s performance exceeds the expectation of the speaker in terms of his jazz solos. The boundaries which function as LMs in the instances are not as obvious as the LMs of the above-and-beyond sense (Excess I). The horizontal excess is expressed with the physical boundary, such as *baseline*, *bar*, *touchline*, *crossbar*, *goal keeper* and *touchline level* (see section Above-and-beyond (Excess I) (2B)). On the other hand, the LM of over-and-above (Excess II) tends to be an imaginary boundary. Although the two senses of *over* convey excess, the over-and-above sense seems to be associated with metaphorical excess, while the above-and-beyond relates to physical excess. This proposition could be supported by the instance of (85) which metaphorically denotes the overflow of excitement.

(83) But **that's going over** **the top** a little bit. <S1A-087 #258>

(84) In his most recent recording for DG, **Bernstein** rather goes **over** **the top** with his jazzing of the solos in Gershwin. <W2B-008 #088>

(85) The excitement boils over. <S2B-027 #142>

Control (5B)

As well as the senses which have been discussed so far, *over* conveys a sense of control (Tyler and Evans, 2003a). The sense may derive from a spatial configuration where one entity is located above the other. Taking a higher position carries a connotation of being superior to others. A stronger animal physically takes a higher position to subdue the other. In a metaphorical manner, the superior in a social hierarchy assumes authority to control the inferior. We will examine the data as to how the co-occurring verb and nouns with *over* are semantically associated with the physical and metaphorical sense of control.

Of 49 instances of the control sense, more than half (27 instances) contain *TAKE* and *over*. Apart from the four instances whose phrase structure is *TAKE* + noun phrase+ *over*, most of them appear to contain a phrasal verb of *TAKE over* as in (86) and (87). *TAKE* basically denotes acquisition from an owner. Therefore, it is not surprising that the verb occurs frequently with the control sense of *over*, since it denotes a transfer of control from a previous authority to a new one.

(86) But when George Bush took over America was slipping into a recession.
<S2B-021 #019>

(87) Today is the twenty-fourth of May and the local streets have been taken over by the gypsies who are about to parade the icon of Sarah from the church down to the sea from where she came,... <S2B-027 #138>

HAVE is also found as a frequent occurring verb of the control sense. However, unlike *TAKE*, the verb does not occur without an object noun, *control*. In other words, *HAVE* tends to appear in the phrase of *HAVE control over*.... This implies that *TAKE over* is diffused to convey a control meaning by the verb and *over* combination alone, while **HAVE over* is unlikely to

denote a control meaning without a particular noun of *control*. The difference between the linguistic representations lies in the linguistic features of the verbs. Therefore, the difference between *TAKE over* and *HAVE control over* illustrates to what extent a verb conveys a particular meaning.

- (88) During the C19th people who claimed they had no control over their inappropriate behaviour were seen as malingerers or fakers. <W1A-007 #027>
- (89) In this way, the control we have over our own lives and environments is constantly eroded. <W2B-013 #010>

The analysis of the corpus data reveals that other frequent verbs of the sense appear to be categorized into two groups: one is the verb which represents a different type of control. For instance, *RULE* and *WIELD* signify a general control, whereas *PRESIDE* refers to the control of assembly as a chairman and *LORD* highlights the arrogance of the person who believes themselves to have control over other people. The other group of control verbs is associated with victory, namely, *TRIUMPH* and *WIN*. The phrase *TRIUMPH/WIN over* is likely to emerge from a metaphor that CONTROL IS RETAINED BY VICTORY¹². Given that the verbs mentioned co-occur with the control sense of *over*, they are likely to contribute to the slightest nuances of the phrasal verbs.

- (90) During the trial, it's been my task to, preside over the trial and decide any questions of law, which may have, arisen. <S2A-061 #003>
- (91) ... and, I'm, I'm rather scared that, you know, that would seem rather artificial to her and as an attempt to win her over. <S1A-031 #186>

Let us turn to the co-occurring nouns. We will see whether the TR and LM with the control sense of *over* retain any particular semantic features. Personal pronouns as TR account

¹² The concept of metaphor is represented in small capitals, while the lemma of a verb is in italic small capitals.

for 40 % of the instances (20 out of 49 instances). This implies that the entity in authority or control tends to be the person; in other words, the situation where a person gains control is described in language more than that involving other agents, such as animals. The prevalence of human control is also reflected in the use of such nouns as *the United Nations*, *authorities*, *company/-ies* and *agencies*. These nouns do not indicate the buildings of the institutions, but metonymically refer to the people who work for them. Thus, virtually the control by the institutions is taken by people. As a result, the TR of the control sense is disposed to be human beings or metonymically represented institutions.

- (92) He said, the, uh, **the United Nations** had no control over **the military action**.
<S1B-027 #113>
- (93) At present **a company** wanting to take over **another** has to show that it is not against the public interest. <W2B-013 #053>

The LMs of the control sense vary from person to place, action and feeling as a target of being controlled. Interestingly, non-physical entities can be also controlled in a certain way. For instance, *responsibility* and *desire* are controlled in a similar manner to when *military action* and *transactions* are in control. Consequently, the TR and LM combination provides a deep insight into control: human beings control persons, places, actions and feelings. To summarise, the control sense of over turns out to retain the linguistic environment where human being or institution as subject is followed by control verbs and the targets of control, which vary from human beings to abstract entities.

- (94) For example, **he** presided over **transactions** involving the transfer of property rights and might be approached to find a solution to village problems.
<W1A-003 #062>
- (95) The only remaining problem will be that it may take several years before **the logic of this situation** triumphs over **the desire** to make a quick profit.

Preference (5C)

The preference sense of *over* belongs to the up cluster, which is based on a spatial configuration in which one entity is located above the other. The configuration gives rise to a metaphorical superiority in terms of selection, as in (96) and (97) provided by (Tyler and Evans, 2003a: 103). For example, the league table tends to list items ranked in descending order with the highest item at the top. This kind of experience is associated with the notion that a preferable item is located above one less favoured.

(96) I would prefer tea over coffee.

(97) I like Beethoven over Mozart.

Surprisingly, only one instance is found in the 480 instances of *over*. It is thus impossible to indicate a tendency of the linguistic behaviours of the co-occurring words due to the insufficiency of examples. Nevertheless, compared with the instance of (98) from data, the examples given by Tyler and Evans seem to be so artificial that no other supplementary components to the TR, LM and verb are added. On the other hand, the empirical data from corpus as in (98) shows the richness of co-occurring words and complexity of the sentence structure. Given that research in cognitive linguistic tends to employ artificial sentences as example, corpus data may provide us with the opportunity to cast light on an unexpected finding that cannot be inferred from the artificial example.

(98) Yet, however, much one might prefer the trilogy over earlier texts, the criteria of purity, continuity and authenticity create more problems than they solve.

Reflexive (6)

The reflexive sense has been discussed as one of the principal senses of *over* (Dewell, 1994; Lakoff 1987; Tyler and Evans, 2003a, 2003b). The sense derives from the mental representation that the starting position and the trajectory of the TR are portrayed even after moving to another position (Figure 5.15 below). For instance, with *The fence fell over* (Lakoff, 1987: 433; Tyler and Evans, 2003a: 104), although the fence lies down at the moment of the utterance, the path starting from a higher point is reflected in the co-occurring verb which denotes falling, that is, *FALL*. As a result, it could be argued whether the reflexive sense is generated from the combination of particular verbs and *over* alone, otherwise whether the typical TR and LM occur with the verb phrase. The data analysis will indicate that the co-occurring TR and LM, as well as the verb, provide the account of the linguistic behaviour of the reflexive *over*.

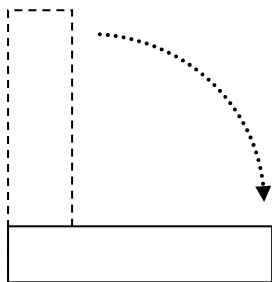

Figure 5.15 The mental representation of the reflexive sense (adapted from Tyler and Evans, 2003a: 104)

ICE sentence code	TR	verb	over	LM
W 2F 001 097	you	'll <i>bend</i>	<i>over</i>	that table
S 2A 050 133 make	him	<i>bend</i>	<i>over</i>	at that point
W 2F 010 050	Catherine	<i>bent</i>	<i>over</i>	the wrists
W 2F 011 014 her	blonde head	was <i>bent</i>	<i>over</i>	a set of papers
W 1B 020 150	I	have <i>bent</i>	<i>over</i>	backwards
S 1A 061 144 my	dustbin	has been <i>blown</i>	<i>over</i>	
S 1B 032 005 if	I	<i>fall</i>	<i>over</i>	
W 1B 004 089 Anyhow	I	didn't <i>fall</i>	<i>over</i>	
W 2F 016 142 caused	her	to <i>fall</i>	<i>over</i>	cliff
W 2F 015 104 found	troops	be <i>falling</i>	<i>over</i>	themselves [troops]
S 1A 081 135	Phil	<i>fell</i>	<i>over</i>	on wild ponds
S 1A 040 434	I	've <i>knocked</i>	<i>over</i>	the thing
W 2F 001 131 and	[he]	<i>lean</i>	<i>over</i>	it [table]
S 1A 003 110 if	you	want to <i>roll</i>	<i>over</i>	
S 1B 010 160 the	pendulum	has <i>swung</i>	<i>over</i>	to the side
W 1B 005 144	I	was ready to <i>tip</i>	<i>over</i>	beer one of them [blokes and girls]
S 2A 062 001 the	plaintiff	<i>tripped</i>	<i>over</i>	a drain
W 2F 017 021 old	woman	<i>tripped</i>	<i>over</i>	a stool
S 1B 017 154 if	you	<i>turn</i>	<i>over</i>	the page
S 2A 061 107 if	you	<i>turn</i>	<i>over</i>	[page]
S 2A 054 060	this	will <i>turn</i>	<i>over</i>	the engine
W 2B 035 026 the	missile	<i>turned</i>	<i>over</i>	to a pre-selected angle
S 1B 032 135 the	composer	<i>turning</i>	<i>over</i>	[score]

Table 5.14 TR and LM of the reflexive sense

Table 5.14 above suggests that *BEND*, *FALL* and *TURN*, which indicate the trajectory of motion, are the frequent verbs with the reflexive sense of *over*. *BEND* and *TURN* recall an arced trajectory from the starting point to the finish: 'to *bend over wrists*' means bending the wrist from a usual position with the hand and lower arm stretching to a relatively unusual angle ((99)). The resulting position alone is not highlighted in the reflexive sense, but the trajectory from start to end is portrayed as path and such particular verbs as *BEND* and *TURN* co-occur with *over*. In the same manner, *FALL over* is associated with the path from up to down ((100)). As far as the combination of the verb and *over* is concerned, the words seem to be semantically harmonised to convey the meaning of reflexive movement. In other words, the connotation of the co-occurring verbs with *over* is unlikely to contradict the reflexive sense. If so, which words create the sense, verb or preposition? I would argue that the combination of sentence components, verb and nouns, contributes to the interpretation of the preposition.

(99) Catherine bent over the wrists, straining to hear. <W2F-010 #050>

(100) Phil fell over on wild ponds and dipping ponds. <S1A-081 #135>

Repetition (6A)

The repetition sense of *over* derives from the reflexive sense, according to the semantic network. This is because this sense is associated with the concept that the trajectory starts from a point and returns there (Figure 5.16 below). The returning path is metaphorically portrayed as repetition of action. For example, in (101) *this* means a course of an event and the sentence indicates that the course will be experienced in the same manner again – as it were literally passing the route of the events. In this section, we will observe whether the co-occurring verb corresponds to the repetition sense, and to what extent the TR and LM characterise the linguistic behaviour of the repetition *over*.

(101) You know, **this** happens over and over again. <S1B-048 #140>

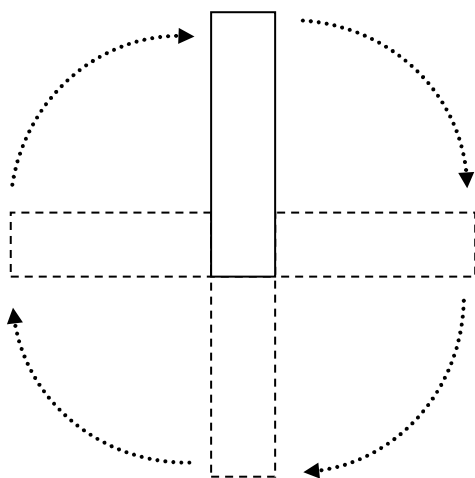

Figure 5.16 The repetition sense (Tyler and Evans, 2003a: 105)

ICE sentence code	TR	verb	LM
W 2B 001 036	I	did not want to have to <i>explain</i>	my illness <i>over and over</i> again
S 1B 048 140	this	<i>happens</i>	<i>over and over</i> again
S 1A 016 042 Do	you	<i>read</i>	the book <i>over and over</i> again
S 2B 039 016	Mr Gorbachev	<i>refers</i>	<i>over and over</i> again
S 1B 023 025	[we]	to <i>renew</i>	<i>experience over and over</i> again
S 1A 016 037	I	keep <i>watching</i>	the film <i>over and over</i> again

Table 5.15 TR and LM of the repetition sense

Six instances of the repetition sense are found in the data. Some of the verbs suggest the feature of repetition: obviously, *RENEW* literally refers to repetition. On the other hand, *READ* and *WATCH* denote the action in which the agent proceeds along the contents of a *book* or *film*. The story of the book and film consists of a series of events and the reader and watcher pass through the events in the course of the story. If they wish to read or watch it again, they need to go back to the start of the story. The action makes a path from beginning to end. In terms of the association of verb, noun and preposition, ‘*read the book*’ and ‘*watching the film*’ seem plausible to co-occur with the repetitive *over*.

(102) And do **you** read the book over and over again. <S1A-016 #042>

(103) **I** keep watching the film over and over again. <S1A-016 #037>

As shown in the examples above, the repetition sense tends to be expressed by the phrase ‘*over and over*’. The twofold *over* phrase is not followed by a noun phrase, which indicates that the *over* is highly likely to be adverb qualifying the preceding verb. The accounts of the *over* senses in this chapter have suggested that adverbial *over* is based on the path schema in general. This in turn implies that the repetition sense is likely to emerge from the path schema. The data also shows that the TR of the repetition *over* tends to be person and people which are expressed by personal pronouns. This finding runs counter to my presupposition that it might be only the noun referring to events or the thing to be repeated, such as *song* and *story*. Yet, in fact, the repetition sense can be employed in the sense that a person reiterates an action of speech and watching such as *EXPLAIN*, *READ*, *REFER* and *WATCH*. In conclusion, the analysis of the data has revealed that the *over* sense corresponds to the meanings of the co-occurring verbs and the LMs, and the TR falls into human beings, which occur somewhat frequently, and events.

5.3.3 Implications about the analysis of the *over* senses in the semantic network

In the previous sections we have observed the analysis of the *over* senses suggested by Tyler and Evans (2003a, 2003b) and the linguistic environment, in particular, the co-occurrence of the verbs with TR and LM nouns. This summary of the analysis will account for the findings as to

- 1) how the central schemas of *over*, above or path schema, are associated with the derived senses
- 2) to what extent the verb contributes to the interpretation of the *over* senses
- 3) whether the TR and LM are involved in conveying the nuances of the senses.

The three types of the central schemas of *over* have been presented in section 5.2.1: flying above and cross (Figure 5.1); path from one place to another (Figure 5.2); locating above and hovering in the air (Figure 5.3). The analysis of the corpus indicates that, given that the schema of flying above and cross is limitedly employed in such a few spatial configurations as flying airplane, the schemas of path and hovering in the air give rise to the derived senses of *over*. The several senses of the preposition are likely to emerge from associations with the prototypical schemas by highlighting an aspect of configuration and using metaphor. The covering sense (3) is likely to derive from highlighting the concealing and spreading attributes of an entity located above; examining (4) and repetition (6) senses originate from metaphorical inferences of path movement, namely that *PASSING AN EYE IS EXAMINATION* and *TRACING THE PATH IS REPETITION*, respectively. The derived senses are traceable to the prototypical schemas, although they seem to radically develop from the central schemata. Over-and-above (Excess II) sense (5A1) is inferred from the metaphor that *MORE QUANTITY ULTIMATELY OVERFLOWS*, and the association of the more sense with *over* is based on our kinaesthetic experiences, such that *UP IS MORE QUANTITY*. Consequently, the derived senses form a network which gradually expands from the central schema to the highly

developed senses through the sense clusters, for instance the up cluster, which functions as sub category of the central schema and sets up a ‘radial network’ (Lakoff, 1987a).

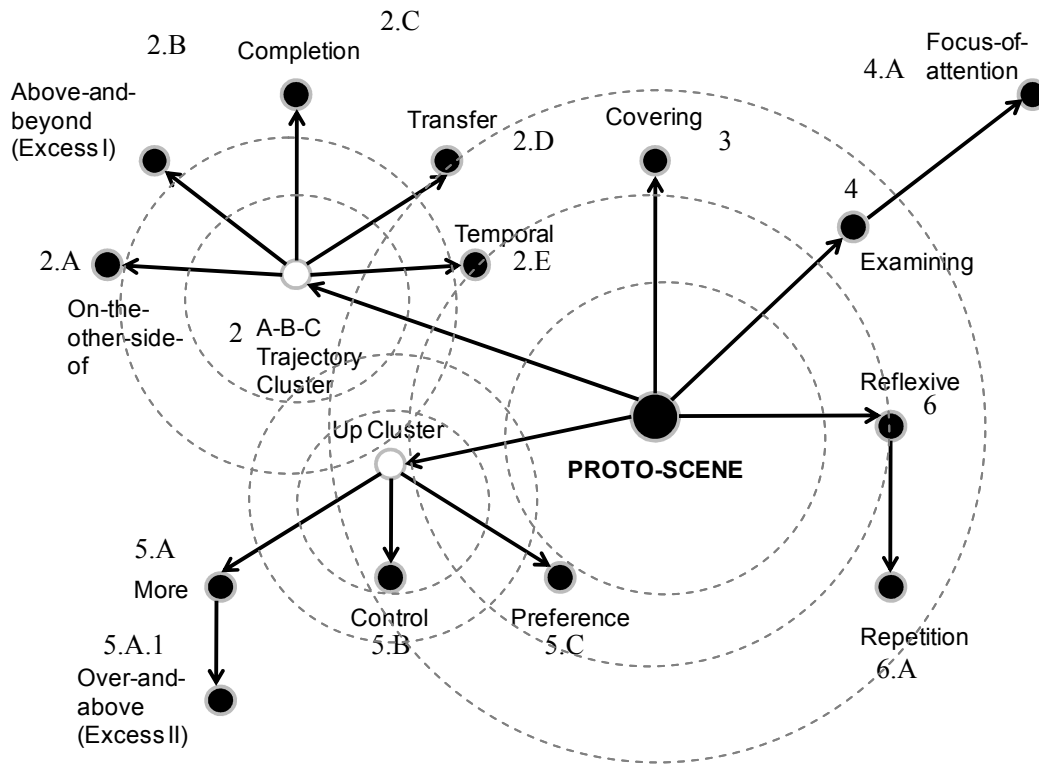

Figure 5.17 Radial network of the *over* senses (adapted from Tyler and Evans, 2003a: 80)

Despite Tyler and Evans’s claim that the semantic network of *over* consists of the proto scene and the two sub-clusters, I would argue that the schemas of locating above and hovering, which is equivalent to the proto scene, and path, equal to the A-B-C trajectory cluster, are likely to be the source of the derived senses. The other sub-cluster, the up cluster, is unlikely to be a genuinely independent source of the senses, rather it seems derivable by adding the metaphor MORE IS UP to the locating above schema. On the other hand, locating above and path schemas make a sharp contrast of spatial configuration between verticality and horizontality. Covering (3) and control (5B) senses are based on the concept that two entities establish a vertical configuration together with verbs ‘GLOSS’ and ‘STAND’, whereas

on-the-other-side-of (2A), completion (2C) and temporal (2E) and other senses derive from a physically and figuratively horizontal path movement, such as physically crossing over a bridge and advancing the stream of time in a metaphorical way. Of the senses of *over*, there exists a sense which may arise from both locating above schema and path: that is, the examining sense (4). When examining, the vantage point is located above the document examined as exemplified by the co-occurring verb ‘*CAST*’, and at the same time the path of eye movement runs through the surface of the document as represented by the frequent verb ‘*GO*’. It could be therefore argued that the senses of *over* are unlikely to divide as the derived senses into one of the two central schemas, rather some senses derive from the amalgamation of locating above schema and path. Figure 5.18 below illustrates the degree to which the senses of *over* associate with the central schemas. As a result, the central schemas might be assumed to be relevant to each derived sense of *over*, varying the degree of relevance from the one pole to the other.

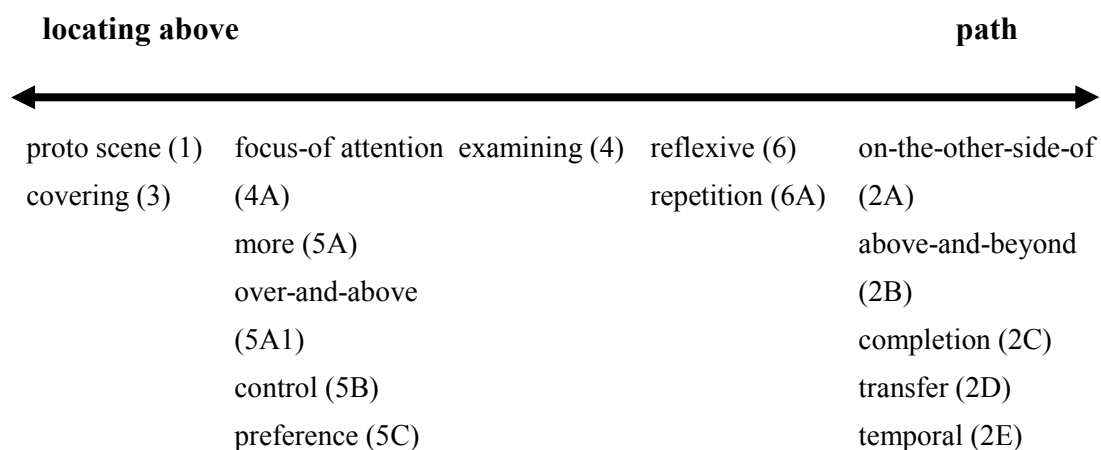

Figure 5.18 Degree of the relevance to the central schemas

Now we turn to the verb. The data analysis has suggested that the meaning of the co-occurring verb corresponds to the *over* sense as a whole. The proto scene *over* (1), which

represents a spatial configuration of one entity locating above the other, occurs frequently with locating verbs such as *LIFT* and *place*. By contrast, *COME* and *GO*, denoting path movement, are diffused with the sense of the on-the-other-side-of (2A) which belongs to the A-B-C trajectory cluster. A considerable highlighting of path schema is likely to affect the function of *over* and the structure of phrase: *over* is an adverb which does not have to precede a noun phrase like a preposition. The transfer sense (2D) denotes delivering something ‘by hand’ and it is expressed correspondingly with a denominalised verb ‘*HAND*’ which derives from the noun of the same linguistic form. *LOOK*, *READ* and *STARE* are frequently used to convey the sense of examining (4) which is carried out by seeing. The control sense (5B) of *over* tends to occur with verbs signifying authority and victory, such as *PRESIDE*, *RULE*, *WIN* and *TRIUMPH*. Some particular verbs, such as *BEND*, *FALL* and *TURN*, appear to be associated with the trajectory implied by the reflexive sense (6). It could then be concluded that the meaning of the verb semantically corresponds to the sense of the co-occurring *over*.

Kreitzer (1997) argues that a complex spatial configuration which is expressed by a phrase containing *over* is generated from the synthesis of the schemas of the preposition and verb. A diagonal path implied by ‘*CLIMB over*’ is assumed to be the mixture of the schemas of climbing and *over*, as illustrated earlier in Figure 5.5. If so, is any type of spatial configuration interpreted by verb and preposition alone? In other words, does a given verb and preposition combination, a so-called ‘phrasal verb’, convey a particular sense in a limited way? This is not the case. As illustrated in examples (104) to (115), phrasal verbs are polysemous phrases which have several meanings within an identical linguistic form. In order to convey a nuance of meanings, the co-occurring nouns might help to differentiate the meanings of sentences containing an identical phrasal verb. However, in fact only a few implicitly suggest the semantic association of preposition with other sentential components, such as verb and nouns (Kreitzer, 1997; Tyler and Evans 2003a, 2003b). I would agree that the co-occurring nouns

also play an essential part in the interpretation of the *over* senses. Let us now turn to analysis of the polysemous phrasal verbs.

Hang over is used in the sense of proto scene (1) and focus-of-attention (4A). The proto scene represents a spatial configuration in which one entity is located above the other; in (104) concrete objects, *FOR SALE signs*, hover above the other concrete objects, *sagging wooden doors*. Such spatial configuration is often experienced in the life of language users and represented by the linguistic form of ‘*HANG over*’. On the other hand, no one could see that *a large question mark* is physically hanging above a demand as in (105). This examining sense may arise from metaphorically mapping the spatial configuration like (105) onto the description of the situation where *the Iraqi demand for reciprocity* is in question. As a result, the nature of the co-occurring nouns before and after the preposition is likely to contribute to interpreting the different senses.

<*HANG over*>

(104) ..., with broken windows and **FOR SALE signs** hanging dispiritedly over **sagging wooden doors**. (1) <W2F-006 #025>

(105) According to the spokesman, **a large question mark** also hangs over **the Iraqi demand for reciprocity**. (4A) <S2B-004 #023>

Likewise, *GO over* is found in several senses of *over*. On-the-other-side-of sense (2A) and above-and-beyond sense (2B) specify concrete objects as attributes of the spatial configuration. Despite the absence of the agent of the phrasal verb, (106) indicates that a person crosses over *a box of seeds*; *the bullets go beyond our head* which refers to the target of the bullets as in (107). The difference of the two senses is likely to lie in the nature of the TR and LM: a box is large enough to go over to the other side and the bullet goes past the target when missing it. Examining sense (4) and over-and-above sense (5A1) distinctively

occur with an abstract noun phrase, particularly as TR following *over*. Neither *the basic procedures* nor *the top* are capable of being physically passed through. In a similar manner to *HANG over*, metaphorical mapping from physical configuration onto abstract takes place in terms of the interpretation of the senses. *The top* with the over-and-above preposition functions as boundary of excess. Again, you can see that the nature of the co-occurring noun, TR and LM, clarifies the subtle nuances of the *over* senses.

<GO over>

(106) Wouldn't be very large but it'd be big enough to go over a box of seeds. (2A)
<S1A-007 #063>

(107) ... and the bullets were going over our head very close to our head because he ran right past us,... (2B) <S2A-050 #160>

(108) Now Tony we'll just go over the basic procedures to start your bike before you sit on it. (4) <S2A-054 #053>

(109) ...but that's going over the top a little bit. (5A1) <S1A-087 258>

The derived senses of the preposition are directly or only indirectly relevant to the central schema; the senses of *over* are highly likely to derive from the locating above and path schemas. The mental representation of the central schema can be conceptually represented by the spatial configuration between the two entities: trajector (TR) and landmark (LM). To put it another way, the reciprocal relationship between TR and LM may contribute to the interpretation of the derived senses of the preposition. It could follow that the examination of the combination of TR and LM might provide us with an experimental account of the diverse senses of *over*. The analysis of *BE over* suggests that the combination of places, *the flat* (TR) and *a disused garage* (LM), may give rise to the locative sense of on-the-other-side-of (2A) in (110); the combination of abstract thoughts, *my confusion* (TR) and *the question* (LM), is associated with the focus-of-attention sense (4A) in (113); and *over* co-occurring with human,

she (TR), and number, seventy (LM), can be interpreted as the sense of more in terms of age (114). Admittedly, this analysis is unlikely to apply to all instances of the *over* senses; in particular, the sentence containing adverbial *over* does not retain a noun phrase following the preposition, as in (111). Despite such weakness, the TR and LM combination could predict the senses of *over* to a certain extent on the basis of cognitive linguistic theory about prepositions.

<BE *over*>

(110) The flat was over a disused garage. (2A) <W2F-006 024>

(111) The political damage may be limited if the fighting is over relatively quickly. (2C) <W2E-006 #084>

(112) That was over Christmas I think that happened. (2E) <S1A-093 #313>

(113) That's right and my confusion was over the question (4A) <S1B-062 #094>.

(114) She is over seventy. (5A) <S1A-027 #262>

(115) Privatisation of these great utilities has loosened what little public control there was over gas over electricity over all the telephones... (5B) <S2B-036 #093>

Nevertheless, a question remains unanswered as to which word – verb, *over* or noun – is responsible for the establishment of the sense: does the preposition play a central role in the combination? Some cognitive linguists seem to imply that the preposition is an independent source which assigns a number of derived senses (Dewell, 1994, 2007; Dirven, 1993; Gucht *et al.*, 2007; Lakoff 1987). Otherwise, as the valency theory (Fillmore, 2008; Thomas *et al.*, 2004) suggests that the verb is accompanied by a direct or ditransitive object, does the verb determine which preposition and noun can follow? I would agree with the theory of phraseology that a meaning arises from a set of phrases. None of the constituents of clause independently contribute to the interpretation of a spatial configuration. Such words as

verb, noun or preposition are highly likely to interrelate to the occurrence. Take the configuration of Figure 5.19 below for instance, the combination of *cat* and *wall* infers that a cat is capable of moving to the other side of a wall; the verb *JUMP* specifies the way in which the cat moves; and the preposition *over* indicates the trajectory of the movement above the wall. From this, I would argue that the senses of *over* are unlikely to lie restrictedly in the preposition; rather, other attributes, verb and the combination of TR and LM noun, also play an essential part in the interpretation of a configuration. In the following section, I will focus on the extent to which the TR and LM combination could account for the senses of *over*.

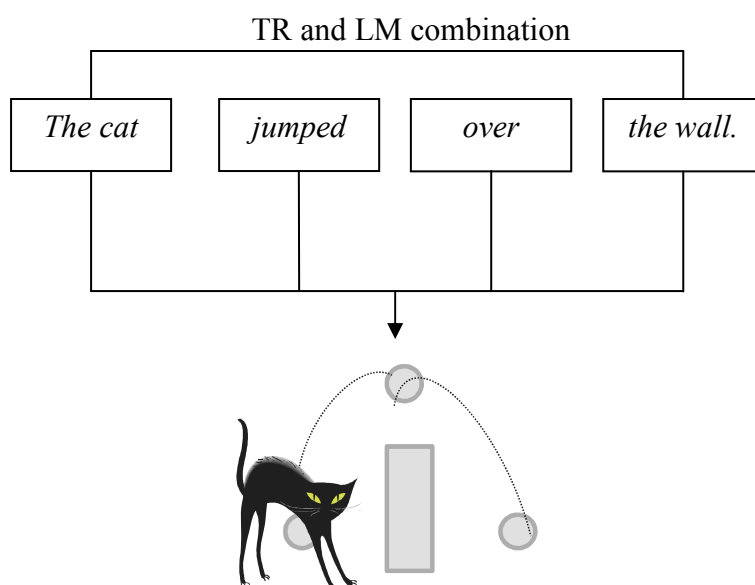

Figure 5.19 Generation of the meaning of *The cat jumped over the wall*

5.4 TR and LM combination

5.4.1 Distribution of TR and LM combination

Given that the preposition is assigned a number of senses, they are likely to originate from the central schema of the preposition. Cognitive linguists point out that the sense of the preposition is based on a spatial configuration which is composed of two entities: trajector (TR), which functions as the focus of attention, and landmark, which establishes a relation as

background to the trajector. Take Figure 5.19 for example again, *the cat* is the trajector and *the wall* is the landmark. As has been discussed in the previous section, the nature of the noun as TR and LM is likely to predict the diverse senses of *over* to a certain extent. Concrete objects tend to be used in locative senses, such as the locating above (1) and on-the-other-side-of senses (2A), whereas abstract concepts, such as time and thoughts, are frequently found in the instances of temporal (2E) and focus-of-attention senses (4A). Moreover, the combination of TR and LM seems to be associated with the interpretation of the preposition. For instance, the combination of *the bullets* and *our head* occurring with *over* indicates that they go beyond the person ((107)); the *over* between *she* and *seventy* can be understood to referring to age ((114)). The co-occurring verb may function by adding information to the spatial configuration of TR and LM combination: a straight trajectory of *the bullets over our head* is represented by GO, while an arced trajectory composed of *a ball over head* is described as loop ((38)). This function of the verb can be accounted for by the integrative schema which is a conceptual synthesis of schemas between spatial configuration and movement as illustrated earlier in Figure 5.5 (Kreitzer, 1997). To put it another way, the meaning of the verb may help to specify a particular spatial configuration by incorporating with the central schema of the preposition. The account of the co-occurring verb will be provided while the TR and LM combination is analysed. In this section, the TR and LM combination will be mainly analysed.

Not all the instances containing *over* establish a combination of TR and LM. Unlike the preposition, adverbial *over* inclines to be isolated from the following TR noun. This is partly because the foregrounding of the path schema makes the reference of the LM unnecessary. As has been discussed earlier, the completion sense of *over* (2C) is independent from the following LM –...*the fighting is over*...((41)), since the completion of the path from start to end is the key of the sense, rather than its destination. Table 5.16 below indicates the

proportion of instances without the noun following *over*. Interestingly, a high proportion of the absence of LM is in the sense based on path schema: repetition (6A) e.g., *over and over*; completion (2C); reflexive (6) e.g., *BEND over*; on-the-other-side-of (2A); and transfer (2D) e.g., *HAND over to someone*. As a result of this, *over* which is not followed by a noun phrase is highly likely to be adverbial and denoting the sense based on the path schema. In this study, 78 instances of adverbial *over* are excluded for the purpose of the analysis; the TR and LM combination of 402 instances will be investigated.

	without LM	instances	propotion of without LM
6A	6	7	86%
2C	5	6	83%
6	8	18	44%
2A	31	110	28%
2D	5	19	26%
5B	11	50	22%
5A1	2	11	18%
3	5	43	12%
4	1	13	8%
2B	1	18	6%
4A	1	36	3%
1	1	40	3%
2E	1	90	1%
5A	0	18	0%
5C	0	1	0%
	78	480	

Table 5.16 The senses of *over* in the order of high proportion without LM

The TR and LM are classified into human beings (H), concrete objects (C) and abstract objects (A). Drawing on Schönefeld's criteria (1999), the classification of HCA is adopted in this study for the following reasons. First, the five sub-categories seem too diverse for the purpose of empirically describing the semantic association between TR and LM. Secondly, an attempt of dichotomy classification, human being or non-human objects, only achieved a statistically insignificant distribution result ($\chi^2 = 0.35$ d.f. = 1 $p = 0.852$). Thirdly, the earlier account of the derived senses of *over* has suggested that the TR and LM of abstract

objects, such as time and thoughts, are likely associated with metaphoric expression of the preposition. Note that a place and building which metonymically refer to the people inside fall into the sub-category of human beings.

		LM		
		H	C	A
TR	Count	17	96	119
	H Expected	16.2	97.5	118.3
	Std. Residual	0.333	-0.313	0.140
	Count	3	60	22
	C Expected	5.9	35.7	43.3
	Std. Residual	-1.401	6.005	-5.216
	Count	8	13	64
	A Expected	5.9	35.7	43.3
	Std. Residual	0.998	-5.625	5.047

$$\chi^2 = 53.538 \quad \text{d.f.} = 4 \quad p < 0.001$$

Table 5.17 HCA combination of TR and LM

Table 5.17 shows that the distribution of the overall distribution of the TR and LM combination is statistically significant in terms of the HCA classification of the instances containing *over*. The standard residual indicates over and under representation in comparison to the expected frequency based on the distribution. According to the results, the CC combination (p=6.005) – the TR and LM are both concrete objects – and the AA combination (p=5.047) – the TR and LM are both abstract objects – are overused, whereas the CA (p=-5.216) and AC (p=-5.625) combinations appear to be underused. The unbalanced distribution may imply that *over* with the combination of concrete objects denotes a spatial configuration of one entity locating above another, or in terms of path sense an object, such as ball and bullet, fly over an object. Abstract objects are also frequently adopted to represent a relationship of time, concepts and activity. In the following section we will examine detailed accounts of overused and underused HCA combinations.

5.4.2 Overused and underused combinations of TR and LM

TRs and LMs used with *over* have been classified into human beings, concrete objects or abstract objects. It has suggested that the combination of concrete object TR and concrete object LM and that of abstract object TR and abstract LM over-represent in the corpus data. Conventional accounts of the senses of prepositions have been provided on the ground that the preposition conveys its diverse senses virtually independently (Lakoff, 1987). However, the comprehensive account of the *over* senses provided by cognitive linguists suggests that other sentential components may involve in interpreting the derived senses of the preposition: for instance, some particular verbs were presented in relation to the *over* senses (Dewell, 1994, 2007; Kreitzer, 1997; Lakoff, 1987). In the same vein, section 5.3.2 has shown that the co-occurring verb semantically corresponds to the sense of *over* to a large extent. Moreover, a number of co-occurring nouns have also been specified in given senses. Based on the assumption that the prototypical mental representation of the preposition is composed of trajector (TR) and landmark (LM) (Tyler and Evans, 2003a), this section will investigate the extent to which the combination of TR and LM can account for the derived senses of *over*. It could then be argued that the sense of *over* is unlikely to be attributed to the preposition alone, but that other sentence components, such as verb and nouns, help to specify a configuration represented by the phrase containing the preposition.

The combination of concrete object TR and concrete object LM is overused as shown in Table 5.17 above. Table 5.18 below indicates that the overused concrete object (TR) plus concrete object (LM) combination frequently occurs exclusively in such senses as ‘proto scene’ (1), ‘on-the-other-side-of’ (2A), ‘above-and-beyond’ (2B) and ‘covering’ (3). In the light of the analysis of the central schema in 5.2.1, the schema of one entity locating above the other and the path schema are prototypical, the overused combination indicates that a spatial configuration where a concrete object locates above and on the other side of the other

concrete object tends to be represented along with *over*. Likewise, the abstract object (TR) plus abstract object (LM) combination is over-represented so that the ‘temporal’ (2E) and ‘focus-of-attention’ sense (4A) appear to be associated with the combination. Now let us turn to reading the concordance lines of the examples to see whether the HCA classification of the TR and LM combination could account for the derived *over* senses.

semantic network		TR x LM combination									sum
		HH	HC	HA	CH	CC	CA	AH	AC	AA	freq
1		3	15	1	1	13	0	3	2	1	39
2	2A	0	43	11	0	19	0	0	3	3	79
	2B	0	2	2	1	10	1	0	1	0	17
	2C	0	0	1	0	0	0	0	0	0	1
	2D	6	4	4	0	0	0	0	0	0	14
	2E	0	0	40	0	0	14	0	0	35	89
3		0	6	8	0	16	1	0	4	3	38
4		0	5	6	0	1	0	0	0	0	12
	4A	2	4	16	0	0	1	1	1	10	35
5	5A	0	0	11	0	0	0	1	0	6	18
	5A1	0	1	4	0	0	2	0	0	2	9
	5B	5	7	15	1	0	3	3	1	4	39
	5C	0	1	0	0	0	0	0	0	0	1
6		1	7	0	0	1	0	0	1	0	10
	6A	0	1	0	0	0	0	0	0	0	1
sum		17	96	119	3	60	22	8	13	64	402

Table 5.18 TR and LM combination with the distribution of the *over* senses

5.4.2.1 Overused CC combination

The CC combination (concrete object TR and concrete object LM) is frequently used to represent a spatial configuration. The configuration between *the paw* and *an object*, generally implying that the paw of an animal is placed above the object (116), can be reasonably inferred from ‘encyclopaedic knowledge’(Taylor, 2003:85), or shared knowledge of conventions and cultures by the language user. The co-occurring verb, *to lift*, helps us to imagine the vertical configuration in space. In a similar manner, it is generally acknowledged that clouds are above a region and *over*, in turn, can be interpreted as the locating above sense (117). The airplane is assumed to be a typical object flying in the air as in (118); in relation to the LM, *your heads*, the preposition conveys the locating above sense.

- (116) Moreover, if a paw was tapped, just before it was due to be lifted, the paw would then be reflexively lifted an increased amount, as if [the paw] being lifted over an object. <W1A-016 #060>
- (117) This material created an invisible radiation cloud which [=cloud] blew over much of Western Europe within days,.. <W2A-030 #010>
- (118) ..., it was like being at the end of a runway as these great planes roared over just above your head,.. <S2A-019 #100>

When the TR concrete object is capable of concealing, the spatial configuration *over* denotes a covering sense. In (119), thick smoke impedes the sight and can result in covering the landmark, *a very large part of the planet*. To convey the covering sense, the nature of the TR is important. As has been examined earlier, the covering sense falls into the other senses of cover: that is, distributive location and multiplex path (Lakoff, 1987). The TR and LM combination of (120), *sanctuaries* and *the country*, which represents places in a region, seems to be associated with the sense of distributive location denoting scattered places in an area. The TR of (121), *the probe*, seems unable to conceal the LM, *the complete surface of interest*; however, the movement of probes on the surface reminds us of the sense of multiplex path, which represents a path movement in all directions.

- (119) ...but the smoke caused by the filthiness and the concentration of the burning could cause huge amounts of havoc over a very large part of the planet. <W2C-029 #008>
- (120) in Josiah's reign was uh concerned that the many sanctuaries that at that point had existed all over the country and the free access,.. <S1B-001 #004>
- (121) Once the probe has moved over the complete surface of interest, all the three dimensional data points may be combined to form a 3D. <W2A-036 #034>

The nature of the TR and LM and its combination are reflected in the *over* senses of on-the-other-side (2A) and above-and-beyond (2B). These senses are likely to derive from the

path schema which represents an A-B-C trajectory. The TR of the *over* senses is supposed to be an entity, *a tank* as in (122), which can move steering a path of A-B-C trajectory. In relation to the TR, the LM should represent a path, *a crossing*. It seems theoretically possible to interpret the configuration between *a tank* and *a crossing* as the TR locating above the LM as in **A tank is over a crossing*; however, the co-occurring verb, *clattered*, specifies the sense of the configuration by prompting the movement of path. Similarly, the TR of (123), *vehicles*, seems to be commonly associated with the image of a path made by driving. Therefore, the sentence containing *over* represents a path of A-B-C trajectory.

(122) The first check to their headlong progress came when a tank clattered over a crossing just ahead. <W2F-015 #026>

(123) However, some larger vehicles speed over them and I wonder what noise empty skip lorries would make if they did likewise.

The above-and-beyond sense can be inferred from the features of the TR and LM of *over*. The TR tends to be an entity which can fly away, such as *ball* and *bullet*, and the LM indicates a boundary, such as *baseline*, which the TR is expected not to go beyond as in (124). Part of human body, namely *head*, is also frequently employed as LM to imply an imaginary boundary of excess indicating that the TR should reach the target LM, but in fact goes over (125). Were it not for the verb, such as *LOOP* and *END up*, the combination of a flying TR and a boundary LM could draw the inference of the above-and-beyond sense. In other words, the combination of the TR and LM and the distinguishing features are obvious enough to convey the above-and-beyond sense; the co-occurring verb seems to assist in specifying a path trajectory.

(124) He ran back probably twenty or thirty yards and took the catch as the ball looped over his head. <S2A-013 #099>

(125) The high volley may look easy to hit, but all too often a player swings at the

ball, with the result that the ball ends up over the baseline. <W2D-013 #130>

5.4.2.2 Overused AA combination

The other overused combination, abstract object TR and abstract object LM, also suggests that the combination of TR and LM is highly relevant to the sense of *over*. The AA combination is frequently found in the sense of temporal (2E) and focus-of-attention (4A). The temporal sense seems to be conveyed mostly by a prepositional phrase containing *over* and a following noun phrase of time, e.g., *over the next year*. However, in relation to the temporal LM noun phrase, the preceding noun can be also specified: *investment, regeneration, research* and *task*. These are the nouns referring to an activity over a period of time which is undertaken for a specific purpose. In consequence, it could be implied that the temporal sense is interpreted in a linguistic environment composed of activity TR and temporal LM. In other words, the temporal sense is exclusively materialised in the environment of activity TR and temporal LM. This follows that a meaning is not expressed by a word, but by phrases and a specific meaning is conveyed by the combination of particular words and phrases (cf. Sinclair, 1991; Hunston and Francis, 2000). The ‘units of meaning’ (Sinclair, 1991), components to which a specific meaning is attributed, are applicable to explaining the semantic association of the TR and LM in the temporal sense. The units consist in ‘collocations’, ‘colligation’, ‘semantic preference’ and ‘semantic prosody’. Collocations are the words which frequently co-occur with a particular word; colligation indicates a grammatical choice of the co-occurring words, while semantic preference represents a semantic choice; and semantic prosody shows the attitude and evaluation of the meaning of the phrase (Sinclair, 2004). The account of Table 5.19 below illustrates the semantic association of the TR and LM in the temporal sense of *over*.

PROSODY	activity undertaken for a specific purpose			
PREFERENCE	activity			temporal
COLLIGATION	<u>noun</u>		<u>preposition</u>	<u>noun</u>
COLLOCATION	<i>investment, regeneration, research, task</i>	...	<i>over</i>	<i>months, distance, years, period</i>

Table 5.19 Units of meaning of the temporal sense *over*

- (126) Uhm this just gives you some idea, uh a graph of some idea of how machine translation res research has fluctuated over the years,.. <S2A-032 #007>
- (127) Fidelity which manages £1.6 billion for 200,000 unit holders, is offering a Personal Equity Plan (Pep) phased investment programme allowing investments to be spread over six or 12 months. <W2C-012 #084>

Some instances of the temporal sense convey nuances of change, in particular deterioration and aggravation of phenomena. Again, the units of meaning are used to describe the semantic environment. The collocations of LM, which follow *over*, are identical with the temporal nouns of activity, but on the other hand the TR nouns preceding the preposition denote phenomena changeable for the worse over a period of time, such as *unemployment*, *hot losses* and *spending*. This indicates that the TR and LM combination of a phenomenon and time retains the semantic prosody of a negative change. As a result, the account of TR and LM combinations allows us to discover detailed semantic associations of the temporal sense.

PROSODY	deterioration and aggravation over time			
PREFERENCE	changeable phenomenon			temporal
COLLIGATION	<u>noun</u>		<u>preposition</u>	<u>noun</u>
COLLOCATION	<i>unemployment, hot losses, spending</i>	...	<i>over</i>	<i>year, years, seasons</i>

Table 5.20 Units of meaning of deterioration and aggravation *over*

- (128) Indeed local estimates suggest that Cambridge unemployment will double over the next year. <S2B-002 #044>
- (129) And our first uh uh view from a satellite of what's going on will be a summary of the heat income and heat uh losses which have been measured by satellites orbiting the earth and averaging over the seasons. <S2A-043 #051>

The focus-of-attention sense of *over* occurs with combination of abstract nouns too. The sense of the semantic network suggested by Tyler and Evans (2003a) gives an equivalent meaning to *about*; that is, in terms of the connotation the focus-of-attention *over* can be substituted with *about*. As shown in Table 5.21 below, the TR nouns, such as *disagreement, controversy, conflict* and other nouns, can be followed by ‘*about*’ and the LMs, such as *charges, interpretation, seizure* and others, largely because the TR and LM combination represents a reaction (TR) to a demand and action (LM). The LM can be interpreted as the content of the TR reaction, hence the semantic equivalency of *over* to *about* may be accepted. Furthermore, the account of the TR and LM combination sheds light on the semantic prosody of the *over* phrase. The TR collocations clearly indicate that the reaction expressed by the *over* phrase tends to be incompatible, except for an instance of *agreement*. This result seems similar to the semantic prosody of the deterioration *over*; however, note that possibly the source text of the corpus comprises of news, which inclines to broadcast incidents and disturbance rather than peaceful scenes.

PROSODY	incompatibility			
PREFERENCE	reaction			demand and action
COLLIGATION	<u>noun</u>		<u>preposition</u>	<u>noun</u>
COLLOCATION	<i>disagreement, controversy, conflict, agreement, confusion, issue</i>	...	<i>over</i>	<i>charges, interpretation, seizure, methods, question, something</i>

Table 5.21 Units of meaning of the focus-of-attention *over*

- (130) These infrequent disagreements tended to arise over charges by me of dishonesty or untruthfulness in a politician. <W2B-015 #052>
- (131) The problem lies in the paucity and the confusing nature of the sources currently available as well as controversy arising over their interpretation. <W1A-001 #026>

The overused CC and AA combinations have helped us to predict the senses of *over* and cast light on the specific semantic prosody of the senses. In the following section, we will see whether the HCA classification is feasible for the underused combinations.

5.4.2.3 Underused CA and AC combination

Table 5.18 indicates that the underused combinations of the TR and LM, concrete object (TR) and abstract object (LM); and abstract object (TR) and concrete object (LM), make a clear contrast with the overused combinations in terms of the HCA classification. Both the overused AA and the underused CA occur with the temporal sense of *over* (2E), and the instances of the overused CC and the underused AC fall into the senses of proto scene (1), on-the-other-side-of (2A) and covering (3). In other words, the temporal sense is overwhelmingly expressed by the AA combination, while underused by the CA combination. Likewise, the CC combination and the AC combination are contrastingly used in terms of the

three senses of *over*. In this section we will explore why the HCA combinations are due to the contrast of the over- and under representations.

Examples (132) and (133) signify the temporal sense with the combination of concrete objects (C) and temporal noun (A). The LMs, *possessions* and *casters*, are by no means abstract objects which appear frequently in the overused AA combination. This implies that, unlike abstract nouns, concrete objects rarely precede the temporal *over*. However, as in (132) and (133), it is likely that the passive occasionally occurs with the temporal preposition. This supposition can be supported by the instances in Table 5.22 which indicate that the CA combination tends to be expressed in the passive – 6 out of 15 instances (40%).

(132) ... it was in a car containing empty suitcases ready to be filled with **some of the many possessions** gathered over the years. <S2B-003 #104>

(133) Some dealers may supply bait of mixed supplies which will mean **casters** being produced over **several days** instead of within several hours. <W2E-017 #107>

ICE sentence code	TR	verb	LM	HCA	sense
S 2A 024 027	that [thing]	's been <i>done</i>	<i>over</i> the last <i>century</i>	CA	2E
S 1B 022 059	that [theaters]	have been <i>established</i>	<i>over</i> a few <i>years</i>	CA	2E
S 2B 003 104	many <i>possessions</i>	<i>gathered</i>	<i>over</i> the <i>years</i>	CA	2E
W 2E 017 107	<i>casters</i>	being <i>produced</i>	<i>over</i> several <i>days</i>	CA	2E
W 2D 011 017	[mobile ions]	to be <i>stored</i>	<i>over</i> <i>winter</i>	CA	2E
S 1B 051 123	the same <i>site</i>	can be <i>used</i>	<i>over</i> [time]	CA	2E

Table 5.22 Passives of the underused CA combination

The other contrast of the overuse and underuse is the CC and AC combination of the ‘proto scene’, ‘on-the-other-side-of’ and ‘covering’ senses. As in (134)-(136), the combination of abstract object TR and concrete object LM seems to convey a figurative meaning; the literal configuration of the TR and LM is unlikely to materialise. For instance, a *curse* never physically hangs over a *place*; *superstition* is incapable of independently travelling over *the world*; and *chill* by definition does not move like people, animals and vehicles. Hence, the AC

combination is interpreted as metaphor by mapping a physical configuration and path movement onto abstract objects. The underuse of the AC combination may imply that the use of metaphor is less common than the representation of spatial configurations and path movements.

(134) Does some sort of curse hang over the place? <W2F-016 #069>

(135) Now uhm this [superstition] for some reason went all over the world.
<S2A-027 #016>

(136) So, it was getting dark and there was an eerie chill coming over the city.
<S2A-050 #070>

The underused combinations have also managed to suggest the linguistic behaviour of the *over* phrases: the scarcity of the CA and AC combination in relation to passive and metaphor. In the next section, we will see the extent to which the distribution of the HCA classification implies statistically insignificant combinations.

5.4.3 Embodied and figurative senses with the TR of human being

Table 5.18 shows that the combination of the TR and LM with human beings, such as the HH, HC and HA combinations, appears to be insignificant in terms of the HCA classification. Despite the result of statistic insignificance, the distribution of the senses in the HC and HA combination seems suggestive of human construal reflected in language on the basis of kinaesthetic experiences and figurative thinking.

The HC combination, human being TR and concrete object LM, occurs relatively frequently in the sense of proto scene (1) and on-the-other-side-of (2A). This suggests that the relationship between human being and concrete object tends to be expressed in a physical configuration of one locating above the other and path, rather than figuratively as conveyed in other senses. As in (137) and (138), the relationship of the involved entities represents that the

TR physically locates above the LM. The association between the HC combination and the spatial configuration sense might be due to our recurrent experiences of such configuration and our conventions of expressing it. Our embodied experiences are highly likely to be reflected in language. The supposition could be supported by the result of the smaller number of above-and-beyond (two instances) and covering instances (six instances) in the HC combination. That is to say, although it is possible to express, it is hardly likely that the human being ‘loops’ over the crossbar of football like a ball and a human physically conceals a concrete object as a sheet and a table cloth do.

(137) In an exclusive report after [ANDREW HOGG] flying over rebel-held territory to Ganda, a town left without hope, ANDREW HOGG reveals hidden tragedy. <W2C-002 #036>

(138) She leaned over the washbasin to rinse her face and hands. <W2F-008 #139>

The on-the-other-side-of sense of the HC combination represents a path movement of a human crossing over a place as in (139), and a human seeing something on the other side of a place as in (140). The most frequent sense of the HC combination suggests that the imaginary line of path is portrayed by the embodied experiences in which the traveller and eyes move.

(139) So he came over here and he got the cheque off me. <S1A-008 #275>

(140) And uh,,you can see the Prime Minister over there on his stand between the uh,,Foreign Secretary and the Defence Secretary... <S2A-011 #024>

The instances of the HA combination indicate that the activity of human beings is engaged in abstract concepts in various manners. The central schema of *over*, locating above and path, is applied to representing human’s activities for abstract objects. For instance, the schema of path is metaphorically mapped onto overcoming the difficulty in which *students* would face in *a much longer course* (141). Conceptual entities, time and age, are also

construed as an object which can be crossed over as in (142) and (144). The human being can control such an abstract entity as *business*, as though they virtually located above the entity and asserted authority (145). As a result, the metaphorical mapping allows us to describe the relationship between human beings and abstract concepts in a number of ways. The pervasiveness of the HA combination may imply that metaphor is ubiquitous in our construal and language.

- (141) It's also **more than most medical students** would get over **a much longer course** too, I think, isn't it. <S1B-044 #110>
- (142) **We**, we've had a problem over **the summer** with the Slade with losing yet another person. <S2A-077 #072>
- (143) It might help to clear my mind if **I** could talk **it** over with someone. <W2F-011 #030>
- (144) If **you** are over **age 60**, or will be 60 in the current tax year, and you are unemployed you may claim Unemployment Benefit as usual. <W2D-004 #089>
- (145) You, in your evidence, **you** seem to talk of taking over **one business** and perhaps only one. <S1B-065 #015>

5.5 Summary of the chapter

Cognitive linguists and scholars of semantics have attempted to provide a full account of preposition senses by adopting the notion of semantic network. The semantic network enables us to associate the prototypical sense with the derived senses. The schema of locating above and path is likely to be the central schema of *over*. The configuration of the schema can be represented by a spatial configuration between focus-centred trajector (TR) and backgrounded landmark (LM). Empirical research into the derived senses has revealed the semantic associations of the co-occurring nouns, verbs and the structure of sentence with each derived sense.

My hypothesis is based on the configuration of the central schema of prepositions: the combination of the TR and the LM can to a certain extent predict the derived senses, since they are assumed to originate from the central schema composed of TR and LM. This approach runs counter to that adopted by cognitive linguists. They claim that the senses of preposition largely lie in the word itself and somewhat relate to the co-occurring verb and world knowledge, while I would argue that the diverse senses of preposition are conveyed by phrases containing *over*, namely the combination of the TR and LM nouns, verb, preposition and other sentential components. In other words, the conventional cognitive approach starts with the preposition, whereas this study attempts to account for the senses by the words and their combination when surrounding prepositions.

The HCA classification of the TR and LM combination – human beings (H), concrete objects (C) and abstract objects (A) – has achieved prediction of the derived senses of *over* despite the fact that more detailed classification might be required in some cases. Furthermore, it sheds light on a clear contrast in configuration of the ‘proto scene’, ‘on-the-side-of’, ‘covering’ and ‘temporal’ senses; and the embodiment and metaphor in language. The 3×3 classification of TR and LM is highly likely to be applicable to providing a comprehensive account of other prepositions.

6. ANALYSIS OF INTO

As observed in previous chapters, the HCA classification of the nouns which specifies their spatial and conceptual relationships – human (H), concrete object (C) and abstract object (A) – is effective in interpreting the senses of *over*, which stretch radially from a physical configuration of substantial entities to a figurative one onto which the primary sense can be projected. More specifically, the central sense of *over* which closely relates to a physical configuration of one thing ‘being located above’ another, and the senses which can be derived from this, are likely to emerge from the central sense when this is mapped onto the scenes which the language user considers analogous or applicable, even when the entities are not concrete.

In the case of *over*, one central sense is exemplified by a scene in which there is a combination of concrete object trajector (TR) and concrete object landmark (LM), as in, for example, *the picture is over the mantel*¹. Or, in contrast with this static configuration, a dynamic relation of animate and inanimate objects can be represented, as in *the cat jumped over the wall*. To judge from the semantic network of the preposition (see Chapter 6, Figure 6.6), the primary senses are highly likely to have been projected onto the derived senses by applying the physical configuration to an abstract relation. For instance, the ‘more’ sense was frequently observed which combine human TR and abstract LM, number and unit, e.g. *If you are over age 60*... Likewise, an analysis of the TR and LM combinations of other derived senses can be found in earlier chapters. For this reason, it may be feasible to establish a semantic network of prepositions based on the relationship of the TR and LM whose properties are human or concrete objects and then the sense of a co-occurring preposition may possibly be interpreted as central or near-central. Conversely, the figurative senses may be

¹ In this instance, trajector and landmark are shaded.

linked to the co-occurrence of abstract TR and LM. This may be because, as discussed in 2.3 (Embodiment), our embodied experiences are closely associated with conceptualisations and language (Evans, 2007a; Johnson, 1987; Lakoff and Johnson, 1980; Lee, 2001; Taylor, 2003). More specifically, what one physically experiences in everyday life by seeing and touching in a configuration of *over* is assumed to develop into a fundamental concept of the preposition. Based on this hypothesis, a principal aim of this chapter is to establish the semantic network of *into* by an HCA combination of the TR and LM; in the pilot study *into* was found to retain a closer approximation to the pattern of HCA distribution for *over* than other prepositions, except for *on* (cf. Chapter 4, Pilot study).

As well as the TR and LM, the analysis of *over* showed that the verb is involved to a large extent in interpreting the configuration indicated by the preposition. A verb co-occurring with the preposition is highly likely to help us interpret whether the TR's action is static or dynamic. For example, *HANG* and *PLACE* indicate that the TR remains static above the LM, whereas *CROSS* and *PASS* convey path movement, where the TR travels from one side to the other side of the LM. Furthermore, distinct covering senses correspond to the occurrence of particular verbs (cf. 5.3.2 Covering (3)): namely, a distributive location is conveyed with the co-occurrence of such verbs as *DEPOSIT*, *DISPLAY* and *HAPPEN*; a multiplex path is conveyed with *DRIFT*, *GO* and *MOVE*; concealing covering with *COVER*, *GLOSS* and *SHEET*. Thus, a verb can be a candidate for analysis in the interpretation of a preposition. In the light of the analysis of *over*, this chapter aims to

- specify a central sense of *into* in conjunction with the HCA combination on the basis of the embodied experiences which arise from the TR and LM of a human (H) and a concrete object (C)
- establish a semantic network of *into* postulating that the HCA combination of abstract object (A) may contribute to the extension of the central sense to the

peripheral senses.

6.1 Distribution of HCA

Before turning to the analysis of HCA classification in order to discover a distinctive HCA distribution pattern of *into*, the distribution pattern of the ICE GB corpus data will be investigated in order to compare it to the pattern of the pilot study and also to contrast it with the distribution pattern of *over*, discussed above.

		LM			
		H	C	A	
TR	H	Frequency	28	111	179
		Expected Freq	14.3	115.5	188.2
		%	4.3%	17.2%	27.7%
		Std. Residual	3.641	-0.419	-0.674
	C	Frequency	0	117	29
		Expected Freq	6.5	53.0	86.4
		%	0.0%	18.1%	4.5%
		Std. Residual	-2.558	8.785	-6.177
	A	Frequency	1	7	175
		Expected Freq	8.2	66.5	108.3
		%	0.2%	1.1%	27.0%
		Std. Residual	-2.515	-7.294	6.406

$$\chi^2 = 236.32 \quad \text{d.f.} = 4 \quad p < 0.001$$

Table 6.1 HCA distribution of the TR and LM with *into*

Table 6.1 above illustrates the distribution of the HCA pattern of phrases containing *into*. Each cell of the table shows the raw frequency, expected frequency, percentage and standard residual. Of these, the figure of the standard residual indicates the degree of overuse and underuse: a positive value of more than 1.96 ($p < 0.05$) signifies overuse and conversely a negative value of less than -1.96 signifies underuse. The overuse combinations HH (human TR and human LM), CC (concrete object TR and concrete object LM) and AA (abstract

object TR and abstract object LM) exceed the value of 3.29 ($p < 0.001$) in terms of standard residual. CC and AA in particular overwhelmingly exceed the value of HH. As for underuse, the following combinations: CH (concrete object TR and human LM); CA (concrete object TR and abstract object LM); AH (abstract object TR and human LM); and AA (abstract object TR and abstract object LM) turn out to be statistically under-represented. As with overuse, a difference exists in the degree of underuse of the four combinations. The negative value of the CA (-6.177) and AC (-7.294) is much lower than that of the CH (-0.419) and AH (-0.674) and the probability of HC and HA is less than one percent ($p < 0.001$ when the absolute value of the residual is more than 2.58). In other words, CA and AC are more significantly under-represented than HC and HA. This distribution pattern of the residual approximately corresponds to the pattern of *into* observed in the pilot study (see Chapter 5). As shown in Table 6.2 below, the distribution pattern of the HCA combination agrees in the overuse of HH, CC and AA, and the underuse of CA and AC, with the exception of the relatively little underused CH and CA. The likeness of the residual pattern is illustrated by the peaks and troughs of the two lines identified in Figure 2 below, given that the gaps between the two lines are maximised for the CC, CA and AC. The quasi-identical patterning implies that the representativeness of *into* examples from the Bank of English, which was employed in the pilot study, and that of the ICE GB is justified.

	HH	HC	HA	CH	CC	CA	AH	AC	AA
Pilot Study	1.969	0.422	-1.441	-1.153	3.081	-2.517	-1.329	-3.314	4.032
ICE GB	3.641	-0.419	-0.674	-2.558	8.785	-6.177	-2.515	-7.294	6.406

Table 6.2 Standard residuals of HCA combinations containing *into* in the pilot study and ICE GB

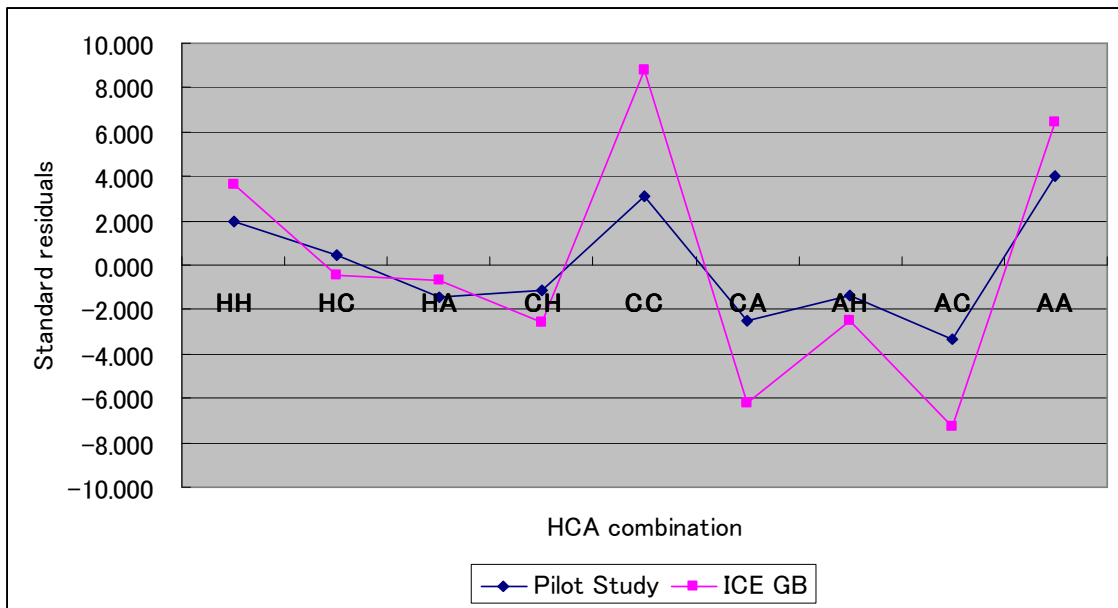

Figure 6.1 Distribution pattern of Table 6.2

Turning to the CH and AH, the underuse seems to occur as a result of the size of the two corpora. Overuse and underuse are statistically estimated according to the distance of an observed frequency from the expected frequency, which is subject to the total value of the row and column cells. Take the HH of Table 6.1, for instance: the expected frequency (14.3) was calculated by multiplying the total frequency of the H row (318) by the H column total (29) and then dividing the product by the whole frequency: $(318 \times 29) \div 647 = 14.3$. Thus, as the total frequency of row and column cells increases, the expected frequency of each cell also increases. Although the CH and AH combination were scarcely ever found in the pilot study (0 and 0 occurrences respectively) or in the present study (0 and 1), a clear difference of the expected frequencies seems to result in the CH and AH of the ICE GB corpus being underused, but not in the pilot study. Expected frequencies are 6.544 and 8.202 of the ICE GB, whereas they are 1.153 and 1.329 in the pilot study. Consequently, it could be again concluded that the distribution patterns of the HCA combination containing *into* are highly likely to agree in the pilot study and the present study.

The pilot study has also suggested that the distribution pattern of *into* is similar to

that of *over*, but not *on* (see Chapter 5). Table 6.3 below shows the residuals of the HCA distribution of the prepositions in the ICE GB corpus. As the table shows, the overused CC and AA and the underused CA and AC are found in the residuals of *over* and *into*. In this respect, the distribution patterns of the prepositions turn out to be similar. What differs in the distribution patterns is the overused HH and the underused CH and AH of *into*. The above discussion of expected frequency shows that CH and AH are underused. The significance of the underuse merely accounts for $p < 5\%$ ($p < 0.05$ when the absolute value of residual starts at 1.96 and rises only to 2.58). This implies that the CA and AC of *into* are more significantly underused than the CH and AH of the preposition, in terms of residuals. The table below seems to suggest that what accounts for the overuse of CC and AA, and the underuse of CA and AC of *over* and *into* is similar.

	HH	HC	HA	CH	CC	CA	AH	AC	AA
OVER	0.118	-0.072	0.020	-0.932	3.830	-3.116	-0.754	-3.779	3.137
INTO	3.641	-0.419	-0.674	-2.558	8.785	-6.177	-2.515	-7.294	6.406

*** $p < 0.001$, ** $p < 0.01$, * $p < 0.05$

Table 6.3 Residuals of *over* and *into* and the significance of overuse and underuse

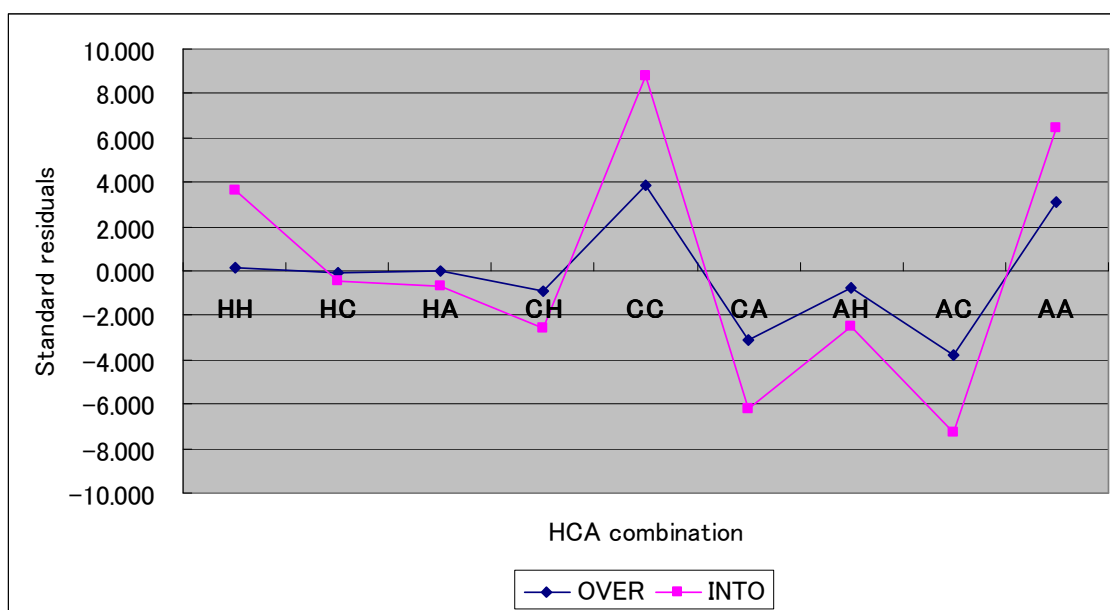

Figure 6.2 Distribution pattern of Table 6.3

As for *into*, the homogeneous combinations of the TR and LM – HH, CC, and AA – are distinctively overused. In the analysis of *over*, it has been claimed that such parallel combinations of the TR and LM may occur more frequently than figurative combinations which transcend the boundary of embodied experiences, such as concrete object TR and abstract object LM, or abstract TR and concrete LM. Figure 6.2 indicates that such parallel combinations as HH, CC and AA are overwhelmingly overused with *into* and the standard residuals are far higher than those of *over*, e.g. *into* HH 3.641, CC 8.785 and AA 6.406; *over* CC 3.830 and AA 3.137 (overuse of the HH combination was not observed in the distribution of *over*). As a result, it can be hypothesised that the strong overuse of the parallel combinations HH, CC and AA may represent typical TR and LM configurations of *into*. Given the suggestion that embodied experiences structure conception (Lakoff, 1987; Lakoff and Johnson, 1999), we see in the next section how the CC combination is associated as a central sense of *into*.

6.2 Central and derived senses of *into*

6.2.1 Mental representation of the central sense of *into*

The central thesis of cognitive linguistics and cognitive semantics is that embodied interaction with our surroundings constitutes our conception of language (Evans, 2007a). If this is so, I would argue that the interaction with physical and concrete entities, rather than abstract ones, necessarily involves our conceptualising the central sense of prepositions.

There are suggestions by linguists who worked before the advent of cognitive linguistics and advocate human cognition in language, that simple mental representations of the configuration of two entities form the model of the central sense of prepositions. For instance, Quirk *et al.* (1985) present a diagram of the mental representation of the central sense of *into* in comparison to that of *in* (Figure 6.3). This seems to indicate that the

difference between the two prepositions lies in the dynamic or static nature of the TR: the TR of *into* penetrates from the outside to the inside of the LM, while the TR of *in* is located inside the LM without any motion from the outside. In the same manner, Dirven (1989) provides a graphic account of *into* which emphasises the LM's capacity to hold volume whereby the TR can penetrate into a counterpart physically and figuratively (Figure 6.4). As a consequence, these accounts of the central sense of *into* are likely to agree in specifying the progression of the TR into the LM.

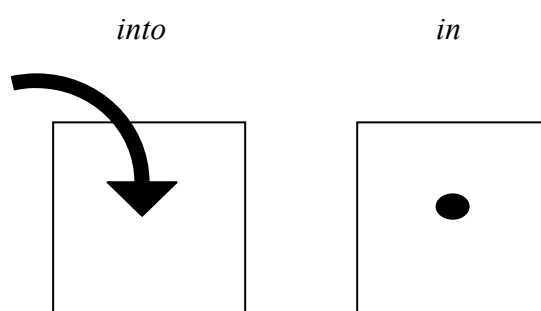

Figure 6.3 Diagrams of prepositions (Quirk et al. 1985: 674)

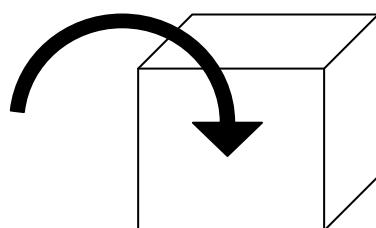

Figure 6.4 Diagram of *into* (Dirven 1989: 537)

By contrast, the proto scene of *into* suggested by Tyler and Evans (2003a) is unlikely to encompass the movement of the TR into LM as a requisite attribute of the central sense of *into* (Figure 6.5 below).

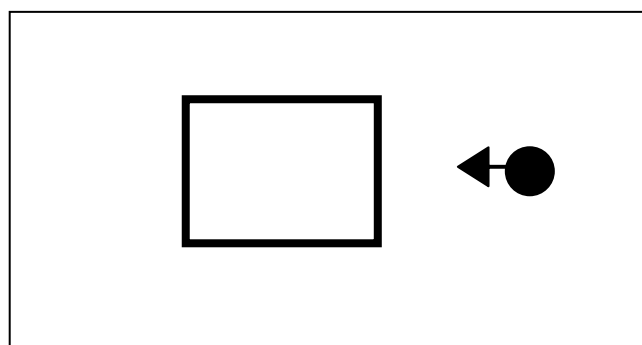

Figure 6.5 Proto-scene for *into* (Tyler and Evans, 2003a: 199)

On the one hand, the rationale behind the exclusion of movement is the claim that “a full analysis of spatial particles involves distinguishing orientation and path and motion” (ibid.: 134). Hence, the proto scene represents a static configuration of preposition which, by focusing on orientation, differs from the conventional representation of a configuration illustrated by diagrams, such as Figures 6.3 and 6.4. On the other hand, the proto scene is assumed to be a semantic framework which is endorsed by linguistic evidence from history, semantics and morphology: namely, 1. earliest attested meaning, 2. predominance in the semantic network, 3. use in composite form, 4. relation to other prepositions, and 5. grammatical predictions (Tyler and Evans, 2001, 2003a, 2003b; cf. 6.2.1 The central schema of *over*). Despite the plausible rationales, not all the criteria of the evidence are applicable to the proto scene of *into*. As for the composite form, no composed verb of *into* is in fact found, though some are found for *over*, e.g. *overlook*. Also, before the establishment of the semantic network which may theoretically emerge from identifying a central sense, it may be difficult to demonstrate predominance in the network and grammatical predictions. It may be the case as a result that the language evidence of the proto scene of *into* was provided in its earliest attested meaning and relation to other prepositions (Tyler and Evans, 2003b). After the *in* of Old English was employed in both a locative sense indicating the inside of LM with the dative case and an orientation sense with the accusative, by the era of Middle English the latter sense

was separately encoded into the other preposition *into* (ibid.). By referring to (1) and (2), the distinction of *into* from *in* indicates that the former preposition implies the indefinite starting point of TR, on the outside of LM, and its orientation to the LM, whereas the latter designates the field of the TR's action inside the LM.

(1) He ran into the room.

(2) He ran in the room.

(Tyler and Evans, 2003a: 199, my underlining)

Even admitting that Tyler and Evan's static proto scene is based on some linguistic evidence, it seems so unlikely as to eliminate the possibility that the advancing movement of the TR into LM is associated with a central sense of *into*. I would argue that the proto scene of the preposition may represent part of the path of advancing movement (Figure 6.6 below). It is 'salience' (Croft and Cruse, 2004: 47) and 'perspectivization' (Taylor, 2003: 93), whereby a particular fragment is construed more prominently than any others, that could explain the incorporation of the orientation sense into the path, as the TR's orientation from the outside of the LM seems to be foregrounded in the course of the advancing movement into the LM (1 in Figure 6.6). There is a sense of penetration in *into*, when used figuratively: *Three days later he slipped into a coma and died* (Francis *et al.*, 1996: 206, my underlining), which can be assumed to be a foregrounded scene at the final point of the path movement (3 in Figure 6.6), while the collision sense, as in *...until he stopped so abruptly [that] Bob bumped into him* (ibid.: 205), seems to originate from highlighting an occasion within the path when the TR and LM come into contact (2 in Figure 6.6).

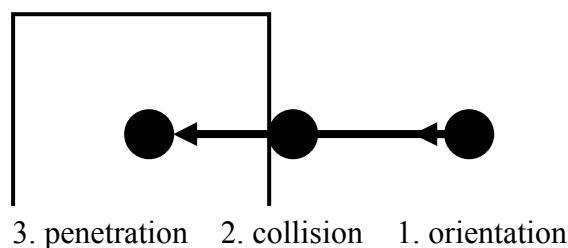

Figure 6.6 Foregrounding in path movement

For this reason, I would argue that ‘path movement’ is one, but only one, of the central senses of *into*. Given that the central sense of *over* remains under discussion (cf. 5.2.1 The central schema of *over*), it remains possible that the static orientation sense and the dynamic path movement sense both function as central points to which the derived senses refer.

6.2.2 Trajector and landmark of *into*

The accounts of prepositions based on the TR and LM seem most likely to be provided by highlighting the TR, since the relationship between the TR and LM is established in the way in which a primarily focused TR appears against the LM as background. However, in terms of the prepositions *into*, *in*, *out of* and *through*², the enclosed and volume-holding nature of the landmark is considered fundamental to the constituting of a TR and LM configuration of the prepositions. As a result, in addition to the TR, the LM of the prepositions including *into* is crucial to a comprehensive account of the preposition. For instance, Quirk *et al.* (1985) suggest that the LM of prepositions is categorized according to the type of dimension: *at* is associated with point LMs, *on* with line or surface LMs, and *in* with area or volume LMs. In the same way, the LM of *into* falls into the type of area or volume dimension, as illustrated in

² *Out* can appear in spatial particles which relate to bounded landmarks (Tyler and Evans, 2003b); however, the present study focuses on prepositions and therefore excludes the adverbial *out* from the group of prepositions with bounded landmarks.

Figure 6.3. Similarly, Dirven (1989) depicts the configuration of *into* in a diagram (Figure 6.4) without great emphasis on the nature of LMs in comparison to other prepositions, but offers the idea that volume is a feature of the LM of *into*. The enclosure and volume-holding nature of the LM is defined as a ‘bounded landmark’ composed of an interior, a boundary and an exterior (Tyler and Evans, 2003b: 178); thus, the three phases of path movement illustrated in Figure 6.6 are likely to constitute a configuration denoted by *into*.

Although the boundary of the LM is important to the configuration of *into*, whether we construe an object as bounded is open to human interpretation. Dirven (1985) and Vandeloise (1991, 1994) point out that the boundary of LM is not necessarily enclosed although a configuration is referred to using the prepositions *into* or *in*. e.g., *Miriam paused in the act of pouring boiling water on the tea leaves spooned into the cups on the table* <W2F-007 #110>³. Obviously, the LM, *the cups*, is not closely bounded, in the sense that the TR, *the tea leaves*, moves into the LM. Figure 6.7 below illustrates that the LM is perceived as having a boundary even if it does not rigidly delineate the interior from the exterior. It is embodied experiences which validate the boundary of a physically partial LM to the extent that we construe it as containing and supporting, functioning as destination, and TRs moving from outside to inside (Tyler and Evans, 2003b). Again, it could be claimed that embodied experiences and human construal closely relate to the configuration of a preposition.

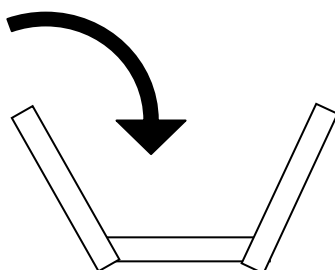

Figure 6.7 Partially bounded LM of *into* (Dirven, 1985: 564)

³ The coded sentence is an extract from the ICE GB corpus.

As regards the TR, Figures 6.3, 6.4, 6.5 and 6.7 indicate that the TR is capable of progressing from the outside of the LM into the inside. It could hence be concluded that the nature of the TR fundamentally includes the mobility necessary to penetrate the LM. It may follow that the TR of *into* is an object adapted for spatial migration, for example, a human being, an animal or a concrete object which can be moved by the force of a third party, namely, in the above case, *Miriam* is the third person who moves the TR, *the tea leaves*, into the LM, *the cups*, <W2F-007 #110>. However, the mobility of the TR is not only applicable to animate and inanimate objects, but also to abstract objects, in a figurative sense in particular. As stated earlier, an incomplete boundary can be regarded as a bounded LM as long as we perceive it as able to perform the functions of containment, target vis à vis the TR, and penetration by the TR. As a result, an abstract object is allowed to serve as a TR due to the relative functions of the LM, as in ...*because it does not yet seem to have the standard of reproducibility and communicability of results that is built into other sciences* <W2A-035 #007>. An abstract object, *the standard*, acts as the TR because of the LM functions of containment and penetration.

In conclusion, the spatial configuration as the central sense of *into* seems likely to be composed of a movable TR, exemplified by humans, animals and concrete objects, and a bounded LM which is allowed to be incomplete as an enclosure to the extent that it is construed as a container by fulfilling the functions of containment, target and penetration. The primary configuration is highly likely to apply to that of the derived senses on the basis of the extension of the LM functions. We will see in the next section how the central sense relates to the peripheral senses.

6.2.3 Derived senses of *into*

Derived senses, as their name suggests, are assumed to originate from the central sense on the

grounds of cognitive linguistics, such that a lexical unit as word constitutes a radial ‘semantic network’ composed of a central sense and peripheral senses (Evans, 2007a; Lakoff, 1987; Ungerer and Schmid, 2006). The related senses share some particular features with each other on the basis of ‘family resemblance’ (Lakoff, 1987; Wittgenstein 1958, see section 2.1). In other words, a derived sense to a certain extent retains the attributes of the central sense and the other senses; the derived sense may be extended from the central one in a figurative and topological manner (cf. sections 2.4 Metonymy and metaphor and 5.3 Corpus research on the guiding senses of *over*).

Long before computer-assisted research into language, Lindkvist (1976) adopted an empirical approach to the analysis of the senses of prepositions by collecting occurrences from literature. He concluded that the senses of *into* in terms of locative conceptions are categorized as shown in Table 6.4.

- 1) Interiority: three-dimensional body, surface, or area
- 2) Motion or direction into analysing with special implications
 - Contact with a surface
 - Progression inside a penetrated space or area
 - Extension into a space or area
 - Implications of withdrawing, confirming, retaining by force, or depth of penetration
 - Motion without reaching or simple direction
 - Perfective implication, etc.

Table 6.4 Senses of *into* by Lindkvist (1976)

The first sense, interiority, is accounted for as being analogous to *in*, which denotes a locative sense in which the two- or three-dimensional LM is construed as bounded. However, the senses of the second group are exemplified by the extension from locative sense to figuratively derived senses. Take the direction sense, for example; a simple direction sense is

as in *auricular canal – the hole leading into the ear. Flood 24.*, while the metaphorical sense of direction is exemplified in *Why not look into the history book and find out whether his father’s secret was completely absurd.... Lewis 47.* (ibid.: 45 and 47, my underlining).

Dirven (1985) provided an account of spatial and figurative senses of *into*: ‘penetration’ e.g. *They put all the toys into a box*, (ibid.: 538, my underlining), which is represented as the primitive image of the central sense by Figure 6.4 and Figure 6.7 above, ‘change of state’, e.g. *The water turned into ice* (ibid.: 564, my underlining) and other senses. Claiming that the spatial sense of the preposition is extended into the sense of transition, Dirven (1985) seems to agree with Lindkvist (1976) in the extension of the central sense into the figurative senses of preposition. Then, a question arises as to which domain the central sense could extend into.

Using the concept of a radial network, Dirven (1993) examines the extension of twelve principal prepositions, *at, on, in, by, with, through, about, over, under, from, off* and *out of*, apart from *into*, and argues that the fundamental spatial conceptions of the prepositions are projected onto metaphorically extended domains, such as time, state, area, manner or means, circumstance, cause or reason. This shows whether or not the prepositions denote the extended meanings (ibid.: 84).

	time	state	area	means manner	circum- stance	cause reason
<i>at</i>	+	+	+	+	+	+
<i>on</i>	+	+	+	+	+	+
<i>in</i>	+	+	+	+	+	+
<i>by</i>	+	-	+	+	+	+
<i>with</i>	-	-	+	+	+	+
<i>through</i>	+	-	-	+	-	+
<i>about</i>	+	-	+	-	-	+
<i>over</i>	+	-	+	-	-	+
<i>under</i>	-	+	-	-	+	+
<i>from</i>	+	-	-	-	-	+
<i>off</i>	-	-	+	-	-	+
<i>out of</i>	-	-	-	-	-	+

Table 6.5 The meaning extensions of prepositions (Dirven, 1993: 84)

While this seminal research is comprehensive, the hypothesis was supported by artificially created example sentences. It might be thus reasonable to carry out the verification of the hypothesis with empirical data. As a result of corpus research, Francis *et al.* (1996) classified the senses of ‘verb *into* noun’ pattern, represented as ‘V *into* n’ in the original, into thirteen groups, as follows⁴:

Verb with prepositional Complement

- 1.1 TURN e.g., *amalgamate, condense, evolve, mushroom*
- 1.2 BREAK e.g., *break, fragment, separate, splinter*

Verb with prepositional Object

- 2.1 CRASH e.g., *bang, cannon, run*
- 2.2 BITE e.g., *bite, dig, sink*
- 2.3 INQUIRE e.g., *delve, look, research*
- 2.4 ENTER e.g., *blunder, get, plunge, venture*
- 2.5 LAPSE e.g., *break, erupt, launch, sink*
- 2.6 CHANGE e.g., *change, slip*
- 2.7 VERBS WITH OTHER MEANINGS e.g., *dip, lash, tap*

⁴ The pattern of V *into* n maps onto in the three different functional configurations, with the ‘*into* phrase’ realising one of prepositional complement, prepositional object, and adjunct. The present research analyses the data without depending on existing grammar theory, but rather in conjunction with the surface structure of language (cf. Huston and Francis, 2000). Therefore, the three types are dealt with as a pattern with a consistent surface structure.

Verb with Adjunct

3.1 INFILTRATE e.g., *ascend, crowd, hack, push*

3.2 DIP e.g., *dig, dip, dive*

3.3 FADE e.g., *blend, melt, recede*

3.4 VERBS WITH OTHER MEANINGS e.g., *spark, spring, stretch*

Now, the senses of the pattern will be categorized into the meaning extensions of prepositions – time, state, area, manner or means, circumstance, cause or reason – and the central locative sense, place. The senses of verb *into* noun group are likely to provide an empirical insight into the meaning extensions of *into*, since the listing of the senses is comprehensive on the basis of corpus data. With 2.7 and 3.4 verbs with other meanings excluded from classification due to their miscellaneous nature, some of the meaning extensions, such as time, manner and means, and cause and reason, were not observed in the pattern (Table 6.6 below). Nevertheless, the seven categories of meaning extension seem plausible for classifying the derived senses of *into*.

place	CRASH (2.1), BITE (2.2), INFILTRATE (3.1), DIP (3.2)
time	
state	TURN (1.1), BREAK (1.2), CHANGE (2.6)
area	INQUIRE (2.3)
manner and means	
circumstances	ENTER (2.4), LAPSE (2.5), FADE (3.3)
cause and reasons	

Table 6.6 Senses of V into n and meaning extensions of prepositions⁵

In conclusion, the derived senses of *into* are likely to emerge from the locative sense with extension into the domains of figurative senses, such as time, state, area, manner or means, circumstance, cause or reason. However, not all the domains necessarily appear in the semantic network of preposition; rather, the pattern of meaning extensions may possibly characterise the distinctive features of the preposition.

⁵ Numbers in brackets indicate the sense group of *Grammar Patterns 1: Verbs* in Francis *et al.* (1996).

6.3 HCA classification of *into*

6.3.1 CC combination and the central sense of *into*

The CC combination has been hypothesised to be the most central sense of preposition *into*, since the configuration is likely to be often experienced in the course of the conceptualisation. As seen in (3) and (4), the configuration of the TR and LM can be observed from the viewpoint of the third party. The penetration of the TR, *train* and *missiles*, into the LM, *station* and *building*, can be recognised as a movement of the simplified diagram shown in Figure 6.4 above. The experience of such scenes along with the text containing *into* may entrench the concept of *into* in the language⁶. Human construal, which allows us to topologically recognise the shape of the entities, is reflected as an incompletely bounded *cylinder* serves as an LM in (5) below. Likewise, a two-dimensional field, *their garden*, is construed as a bounded entity in (6) despite the fact that the LM may possibly not be bounded by a physical fence. The penetration sense of *into*, a dynamic part of the central sense, was found in 56 instances (48.3 %) in 117 instances of the CC combination.

- (3) If you can, wait until **the train** pulls into **a station** before pulling the cord... <W2D-009 #163>
- (4) Last evening **two Cruise missiles** could easily be seen almost drifting across the skyline to plummet into **a large building** on the outskirts of Baghdad. <S2B-015 #048>
- (5) When hot water is drawn from the taps, **new cold water** is fed into **the cylinder** from the cold storage tank above. <W2D-012 #099>
- (6) ... it was an action for nuisance concerning the occupants fairly recent occupants of a housing estate who complained about **cricket balls** coming into **their garden** from the local cricket pitch. <S2A-044 #090>

The static variety of the central sense of *into* is direction and 18 cases of this

⁶ Of course, there might be a refutation that language comes first, as some claim (Teubert, 2010, see section 2.2.3 above). However, I would agree that environment interrelates with the conceptualisation of language.

(15.5 %) were found in the data. The TR of the static sense obviously differs in being movable. The TRs of (3) to (6) are capable of moving from their places to where the LMs are located, whilst the static TRs of (7), in which *door* is unlikely to move without inhibition, are indicative of heading towards the direction of the LMs. However, a small number of instances were found in which the TR remains static in relation to the LM. It could thus be implied that the features of the TR may differentiate between the dynamic and static senses of *into* phrases

(7) The door opened directly into the living room. <W2F-006 #054>

As argued earlier, with reference to Figure 6.6 , the senses of orientation, collision and penetration denoted by *into* phrases are hypothesised as a foregrounded phase of path movement. More specifically, the collision sense seems to emerge from a scene where a TR moves into an LM, but stops on the surface of the LM. To confirm this, (8) exemplifies that the TR, *Daimler*, was stuck in the penetration into the LM, *sports car*, because of the nature of the LM whose materials do not let the TR penetrate thoroughly. The function of the TR in relation to the LM also seems relevant to the interpretation of penetration without reaching the core of the LM. As in (9), characters, *hieroglyphs*, are inscribed on a board, *limestone*, in order for others to read the message; so that the TR remains on the surface of the LM without disappearing into the inside of it. Similarly, *owl windows* are supposed to be embedded in the wall of the construction, *barns*; otherwise, birds cannot enter the barns (10). As a result, it could be claimed that the function performed by the TR and LM may relate to the interpretation of the collision sense of *into* phrases.

(8) Mr Les Crewes, whose daughter Joanne died when Lambert's Daimler crashed into a sports car last May, said he had no sympathy for the man behind the wheel. <S2B-017 #055>

(9) And this as we have always said is the real measure of skill because the

hieroglyphs here are incised into the limestone. <S2A-052 #070>

- (10) And as early as the seventeenth century special owl windows were built into barns, to encourage them to nest there and so, of course, rid the farm of rats and mice, ... <S2B-031 #088>

I would argue that the static sense of the central sense of *into*, orientation, is associated with the reflexive sense of ‘change of state’. Dirven (1985: 564) introduced a figurative sense of *into* which conveys transition from one state to another, e.g., *to turn water into ice; to change coins into banknotes; to make a sheet of paper into an airplane* (my underlining). This sense seems to indicate the orientation of change from one state to another, such as from *water* to *ice*, without the path movement to which the dynamic sense relates. The corpus data suggest that there are two senses of reflexive: ‘change into parts or pieces’ and ‘metamorphosis’. The former denotes that a whole entity is separated into smaller parts, as in (11), and, conversely that different elements are combined into one whole entity, as in (12). The latter signifies that an entity changes its appearance into an entirely different form, as in (13).

- (11) Carefully divide the paper into quarters, horizontally and vertically, to create 16 squares. <W2D-019 #107>
- (12) I suggested that in fact the five trees could be combined into a single one by combining the root entries of each into a single higher-level selection <W1A-005 #018>
- (13) I’m thinking of turning my kitchen into the Eastenders’ laundrette. <W1B-002 #098>

The change into parts sense shows a distinctive feature of the LM denoting number, e.g., *thirds* and *quarters*, and unit, e.g., *chunks*, *sorts*, *regions*, *areas* and *groups*, as seen in Table 6.7 below. It should be also noted that the passive tends to be used in terms of sentence

structure. As a result, the clause pattern of the sense can be deduced, as shown in Figure 6.8 below.

ICE sentence code	TR		verb		LM
W 1A 005 018	five	trees	could be	combined	into a single one
W 2A 038 072	reusable	modules	to be	combined	into a variety of module
W 2D 020 047	the	bread		cut	into 1 inch chunks
W 2B 038 060	a large circular	wafer	which is	diced	into individual chips
S 2A 051 038		them [organisms]	you can	divide	into general sorts
W 2B 025 024	the	oceans of the world		divide	into two main basins
W 2D 019 102	an	edge	to	divide	into accurate thirds
W 2D 019 107	the	paper	to	divide	into quarters
S 2A 047 040		Mali	was	divided	into seven regions
S 2A 051 039	One of the	sorts [cell]	is	divided	into crawling
S 2A 052 088		It [wall]	is	divided	into that grid
S 2B 044 033	the	country	is	divided	into small areas
S 2B 045 053	horizontal	circle	was	divided	into ten minutes of arc
W 1A 006 060	The	map	must be	divided	into specific areas
W 2A 024 059	The	fibres within a nerve	can be	divided	into three groups
W 2B 039 003	a membrane	keyboard	is	divided	into 128 keys
W 2B 039 008		keyboard	might be	divided	into only two areas
W 2A 028 093	the first	component		split	into groups

Table 6.7 TR and LM in change into parts sense

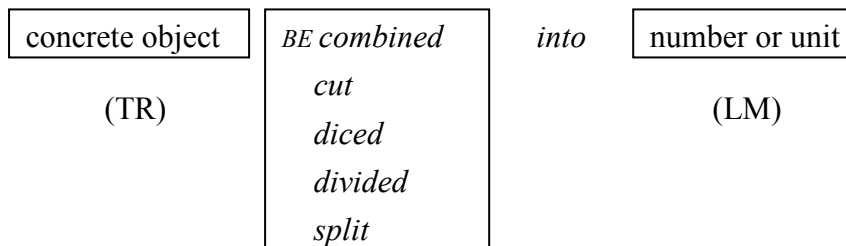

Figure 6.8 Clause pattern of the change into parts sense in CC combination

So far, the two central senses and five derived senses have been examined and the occurrence of instances and their proportion are indicated as follows:

senses and clusters	Freq.	%
Penetration	56	48.3%
Orientation	7	6.0%
Collision		
Affecting surface, embedded	18	15.5%
Reflexive		
Change into parts or pieces	18	15.5%
Metamorphosis	17	14.7%
sum	116	100.0%

Table 6.8 Distribution of the senses in CC combination

Of these, the collision sense and the reflexive sense are likely to function as a cluster of other senses. The change into parts sense and the metamorphosis sense seem to share the original meaning of reflexivity, while the affecting surface, embedded sense may be derived from collision by the function of the TR and LM. Consequently, the semantic network of the CC combination with *into* can be deduced as shown in Figure 6.9 below; the circle size of the senses in the semantic network is reflected by the occurrence in the data. This illustrates that the dynamic central sense, penetration, occupies nearly half of the occurrences (48.3%) and ‘the reflexive cluster’ which retains the subordinate senses, such as change into parts and metamorphosis (15.5% and 14.7% respectively), accounts for more than 30 percent in total. Although the most frequent is not necessarily prototypical (Shortall, 2007), it could be argued that the two frequent senses are highly likely to be entrenched through their use in the CC combination of *into*. In the same way, the semantic network of the other TR and LM combinations are examined next in order to explore whether the HCA combination could account for the senses of *into* phrases.

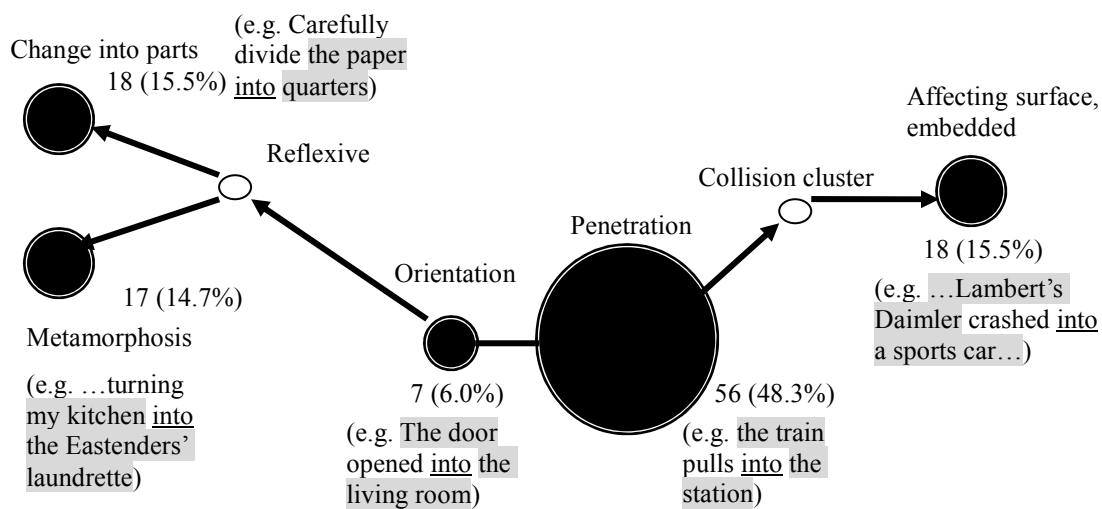

Figure 6.9 Semantic network of CC combinations

6.3.2 HC and CH combination

The HC combination, which is composed of human TR and concrete object LM, is likely to relate closely to scenes where a person enters a construction, as in (14) below. No fewer than 80% (93 instances) out of 112 instances of HC combination fall into the penetration sense. The configuration between TR and LM, which is apparently affected by the nature of the LM in particular, gives rise to the co-occurrence of particular verbs. For instance, as in (15) a *cupboard* is an unlikely LM for someone to enter without inconvenience; *GET* indicates the difficulty of doing so. When the TR is human and the LM is a house, *MOVE*, unlike *COME*, *GO* and *GET*, means the removal of accommodation. Furthermore, the configuration of example (17) shows that the particular TR and LM, *troops* and *Iraqi territory*, although the meaning of the co-occurring verb *GO* is relatively neutral, gives rise to an interpretation of progress with a military purpose. This may arise partly from our world knowledge of a particular TR and LM (Tyler and Evans, 2001, 2003a, 2003b; cf. 6.2.3. Sentential components of senses of *over*).

(14) It was when Charles came into the room. <S1A-018 #256>

(15) It's a little fetish I've got, <laugh> getting into the cupboard, <S1A-040 #072>

- (16) The removal lorry has been booked to start moving **the Thatchers** out of Downing Street and into **their new house in Dulwich** on Monday. <S2B-003 #094>
- (17) Uh, the, the, the fact is that it must be right for **our troops** to go into **Iraqi territory**. <S1B-027 #094>

The penetration sense develops into some derived senses in HC combination, as well. When the human TR moves for the purpose of evacuation and the LM serves as shelter, the path movement in the opposite direction to adversary can be considered a kind of ‘withdrawal’ as in (18). With the LM metonymically referring to the people, a phrase containing *into* conveys the sense in which the TR ‘integrates’ into the LM as part of a social group, as in (19).

- (18) **You** have to, have to retreat into **Stoney Abbey** or the island in Sardinia...<S1B-045 #109>
- (19) In book II ch 21 Adomnan tells of ‘a niggardly rich man, Vigenus’ who didn’t receive **Columba** into **his house**. <W1A-002 #060>

In contrast with the dynamic sense of penetration, the other central sense, orientation, is likely to relate to the scene where the TR casts a glance at the LM without moving from the standpoint, or the TR approaches the LM without penetration. The verbs of Table 6.9 below indicate the act of seeing something, such as *GAZE* and *SEE*, and various approaches to LM, such as *HEAD*, *LEAN* and *STEP*.

ICE sentence code	TR	verb	LM
W 2B 004 123	we	still gazing	into every shop window
S 2B 027 117	many thousands	are heading	into the town
W 2D 013 033	Connors	is leaning	into the shot
W 1B 011 018	artists who	want to live	some way into London
S 1A 089 006	you	can see	into the cavity
W 2D 009 087		[people] to see	into [buses] from outside
W 2D 013 084		[you] try to step	into the shot

Table 6.9 TR, LM and verbs in the orientation sense of HC combination

When the casting of sight takes place under scrutiny, the TR shows an intention to ‘examine’ the LM. The LMs of (20) and (21) are examined by the human TR – the TR of (20) is assumed to be an engineer – in the way in which the TR is carefully orientated to the LM. The difference of the derived sense from the central sense is whether there is scrupulous attention by the TR, which is drawn from the inference of such co-occurring verbs as *CHECK*, *LOOK* and *RESEARCH*, towards the LM.

- (20) The thickness of the pads can be checked by looking into the end of the brake calliper. <W2D-018 #038>
- (21) ...and the particular enzyme that I’m researching into is phospholypase <sic.> C. <S2A-034 #111>

In order to contrast the CC and HC combinations, the semantic networks illustrated in Figures 6.9 and 6.10 are examined, and in doing so it seems feasible to discuss the hypothesis that the CC combination closely relates to the central sense of *into*. First, it is obvious that the penetration sense occurs more frequently in the HC combination than the CC combination. In terms of not only the raw frequency but the proportion in the combination, it is revealed that the scene where a person enters a construction occurs frequently in the empirical language data. This seems to reject the hypothesis that the configuration of the central sense of *into* is that one concrete object enters another; however, it is the case that the CC combination occurs as frequently as the HC combination. This different view of either the inside or outside of the TR is applicable to the central senses in the HC and CC combinations. The difference between the combinations may arise from the configuration where the language user sees the TR penetrating the LM from a particular viewpoint, in this case from the broadcasting booth of a football match, as in (22), whereas the sense of the HC combination in (23) denotes that the TR serves as the doer against the LM as well as the

viewer of the configuration. Most importantly, both combinations appear to occur frequently in the data.

- (22) If they succeed, **the ball** will get into **the prime target area** at the back of the defence. <W2D-015 #042>
- (23) What time would **I** get into **New York**, cos I want to be in for a dinner.<S1A-074 #282>

Secondly, the semantic network of the CC combination distinctively features in terms of the derivation of the sense: the change into parts sense and metamorphosis sense, which do not appear in the semantic network of the HC combination. This may be largely because humans are highly unlikely to separate into physical elements or metamorphose into a concrete object. In terms of predominance in the semantic network (Tyler and Evans, 2001, 2003a, 2003b), the CC combination shows a wider predominance with such derived senses as collision and reflexive, whereas the HC combination is unevenly distributed in the penetration sense. If the attribute of the central sense is hypothesised as being capable of developing into many derived senses, the CC combination seems more likely than the HC combination.

As a consequence of these findings, I would propose a revised hypothesis that both the CC and HC combination possibly relate to the central sense of the *into* phrases. It should be noted that the CH combination is not examined, due to the absence in the data of any instances.

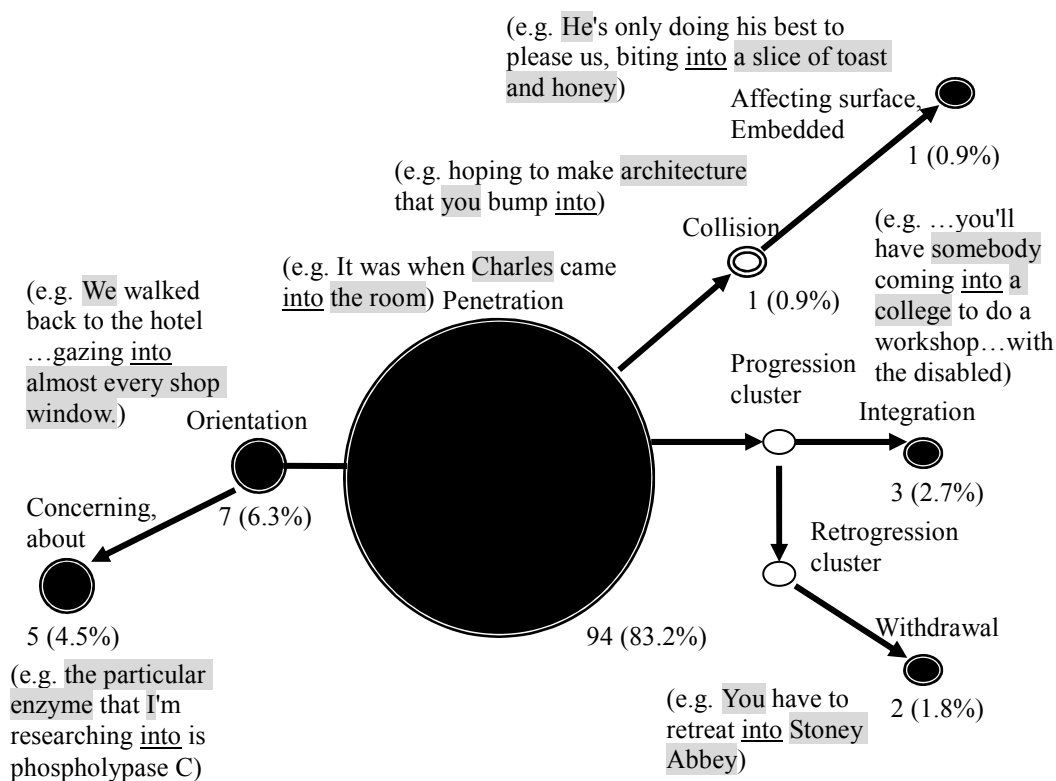

Figure 6.10 Semantic network of HC combination

6.3.3 HH combination

The semantic network of the HH combination retains a feature which distinguishes it from the CC and HC combinations. As shown in Figure 6.11 below, the derived senses, such as changing into parts, metamorphosis, integration and encounter, occupy most of the instances (89.3 %, 25 out of 28 instances), while the central sense, penetration, is found to occur with a low frequency (10.7 %, 3 instances). This may be due to the fact that people rarely speak of penetration by a human of another human body – yet such language can be used on a few occasions, for example, in the discussion of whether or not a rape has taken place (Richards, 2010, personal communication). Few instances of the other central sense, orientation, were found in the data although it is possible for one person to face in the direction of another. Instead of *into*, *to* is used in this sense as in *She was thinking of leaving when he turned to her and said, “Your eyes are beautiful”* (McBee, 2009, my underlining). The derived senses of the

HH combination mostly originate through such clusters as ‘reflexive’ and ‘collision’. This implies that senses which are highly developed from the central ones frequently occur in the combination. The semantic development of all the derived senses is examined below, in turn.

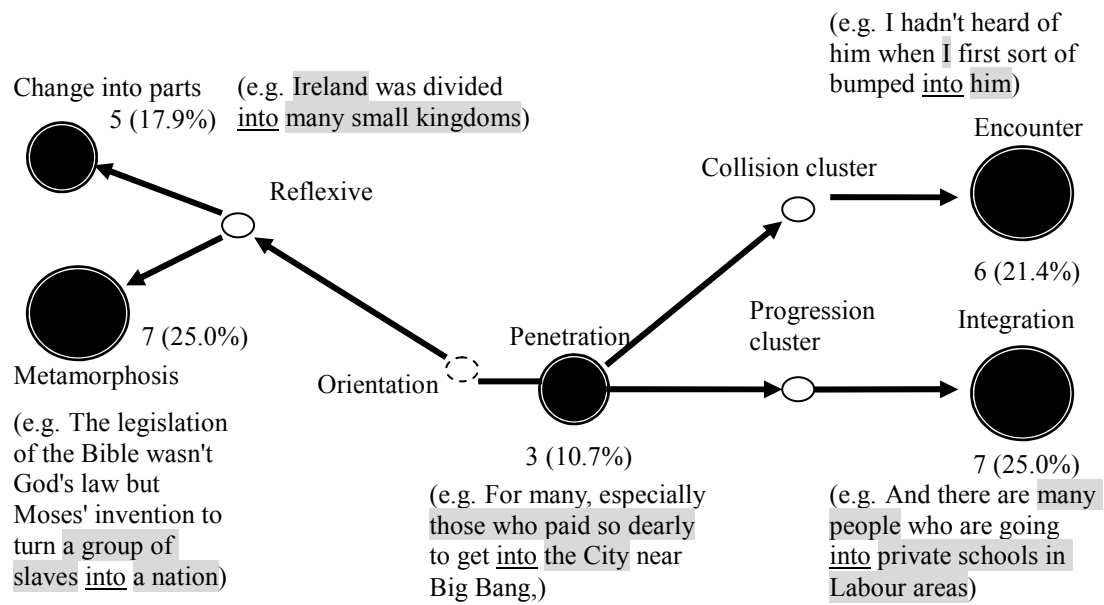

Figure 6.11 Semantic network of HH combination

Regarding the ‘change into parts’ sense, the TR and the LM metonymically refer to the people who belong to a group or organisation, as in (24). Like the clause pattern in the CC combination (Figure 6.8 above), the change into parts sense in the HH combination retains the pattern of *BE divided* followed by a unit LM. The difference between the combinations is that the LM of the HH combination is an ‘intentional object’ (Crane, 2001, Gorman, 2006) which metonymically represents those who work in a group. Similarly, the metamorphosis sense occurs with the LM referring to the people of a group, such as *confederation* and *nation*, which follows such verbs as *TURN* as in (25) and (26). This implies as a result that the metonymy of the LM may feature the reflexive sense of the HH combination.

ICE sentence code	TR	verb	LM
S 2A 022 003	Gaul as a whole	<i>divided into</i>	three parts
W 1A 002 010	Ireland	was <i>divided into</i>	kingdoms
W 2A 017 072	the world	is <i>divided into</i>	competing warrior- states
W 2A 006 064	those varieties Protestant who	had <i>formed into</i>	pressure- groups
S 1B 075 155	computing centres	were <i>grouped into</i>	so-called coordinating centre

Table 6.10 TR, LM and verbs in the change into parts sense of HH combination

- (24) **Gaul** as a whole divided into **three parts**, one of which is inhabited by the Belgae, another by the Aquitani,... <S2A-022 #003>
- (25) **Yugoslavia**, which had been set up again as a federation of nations, was turned into **a confederation of territories** with the 1974 Constitution. <W2B-007 #095>
- (26) The legislation of the Bible wasn't God's law but Moses' invention to turn **a group of slaves** into **a nation**. <S2B-029 #076>

Such metonymy of the LM is also found in a derived sense from the penetration sense. The *into* phrase of the HH combination can denote the 'integration' sense, in which the TR becomes a member of the LM. Take (27) for example: the TR, *people*, goes into the LM, *private schools*, but this does not mean physical penetration of the TR into the building of the LM. Rather, it means that the integration of the TR into the group referred to by the LM, in this case becoming pupils of *private schools*. A negatively judged integration of the TR into the LM is also expressed, as in (28), by the co-occurring verb, *admitting*, which is likely to colour the evaluation.

- (27) And there are **many people** who are going into **private schools** in Labour areas, uh, because of the state of state schools,... <S1B-039 #108>
- (28) There are charges that these culminated in the kidnapping and execution of former Premier Aldo Moro, whose insistence on defying an American veto on admitting **Communists** into **the Cabinet** infuriated Washington. <W2C-010 #026>

As well as metonymy, metaphor plays an essential role in a derived sense of the HH

combination. The ‘encounter’ sense is likely to emerge from the collision cluster. It is obvious that, with this sense, the TR does not literally ‘*bump*’ into or collide with the LM. It does, however, convey a scene where the TR unexpectedly encounters the LM as though they collided physically. The metaphorical sense seems prone to occur with a personal pronoun, as shown in Table 6.11. A result of corpus research, that the personal pronoun is frequent in conversation (Biber *et al.*, 2002), agrees with the finding that the sense is mostly found in the spoken register, which is marked S in the table. This may imply that the encounter sense tends to occur in spoken language.

ICE sentence code	TR	verb	LM
S 1A 036 068 after that time	I	<i>bumped into</i>	her
S 1A 036 080 when	I	<i>bumped into</i>	her
S 1A 058 167	I first sort of	<i>bumped into</i>	him
S 1A 100 124	I	<i>bumped into</i>	somebody else
S 2B 025 053	I now	<i>ran into</i>	long-lost friend
W 1B 016 063 if	you	should <i>run into</i>	me

Table 6.11 TR, LM and verbs in the encounter sense of HH combination

6.3.4 HA combination

The HA combination (human TR and abstract object LM) is not significantly under- or overused in terms of the chi-square test due to the expected frequency being affected by the high total frequency of the H row and the A column⁷. This means that the distribution pattern of the HCA combination of the *into* phrases is significant, but it does not result from the HA combination. However, HA occurs more often than any other combination in the data and it demonstrates a variety of metaphor whereby the spatial configuration of *into* is mapped onto a metaphorical configuration. Thus it may be worth examining the instances of the HA combination in order to see how the derived senses metaphorically develop from the central senses.

⁷ The expected frequency of the HA combination is 188.2, which is calculated by multiplying the total frequency of the H row, 318, by that of A column, 383, and then dividing the product by the total frequency, 647.

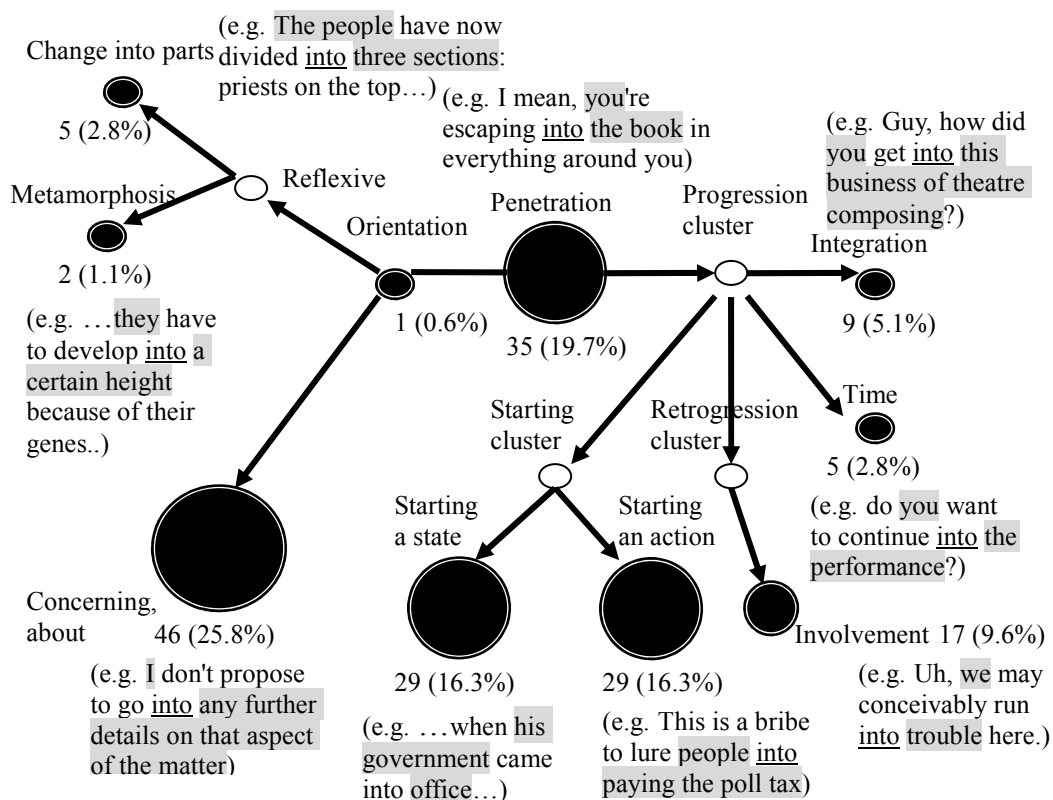

Figure 6.12 Semantic network of HA combination

Figure 6.12 shows that no fewer than nine senses and four clusters appear in the semantic network of the HA combination. In addition, such senses as ‘time’, ‘involvement’, ‘starting an action and a state’, and ‘concerning/about’, are distinctively used to show the multiplicity of the combination by the projection of metaphor. For instance, the ‘integration’ sense occurs in the HH combination too, as when a person becomes a member of a group, while the integration of the HA combination metaphorically denotes that a person launches into another field, such as *business* and *tradition*, as in (29) and (30).

(29) Guy, how did you get into this business of theatre composing. <S1B-023 #008>

(30) The task of the deracinated western Jew was to participate in a kind of reverse assimilation and to reintegrate himself into his vital tradition. <S2B-042 #069>

The senses in the progression cluster are unlikely to represent movement from one place to another. Rather, they metaphorically denote transition from one state to another. The ‘time’ sense of the cluster also denotes time transition, as though the human TR were advancing into the LM of another time span. Not being a bounded container, the LM, such as *age*, *century*, *game nine* and *performance*, serves the function in a metaphorical manner, as an entity which lets the TR in. Of these, *game nine* and *performance*, despite being units of time, metonymically refer to the time when they took place.

ICE setence code	TR	verb	LM
S 1A 001 136	you	want to continue	into the performance
S 2A 038 066	[people]	wishing to get	into the second age
S 2A 060 092	we	get	into the mid seventh century
W 1A 001 047	Verulanium	which appears to have survived	well into the fifth century
W 2C 004 007	they	team went	into game nine

Table 6.12 TR, LM and verbs in the time sense of HA combination

When the progression of a person is deemed to be negative, the incident where s/he falls into unfavourable circumstances is categorized in the ‘involvement’ sense. The twenty instances of the sense occur exclusively in the HA combination. This may imply that the configuration between human and abstract object tends to be expressed in a metaphoric manner, whereby a *country* goes into a *slide* and *companies* plunge into *problems* ((31) and (32), Figure 6.13 below).

- (31) For this is a country which is not only unaccustomed to the swings and roundabouts of boom and recession, but **it** is also going **into** a **catastrophic slide** from a starting point of empty shops, queues and reduced living standards. <W2E-008 #016>
- (32) In the deepening recession **good companies as well as bad** are being plunged **into liquidity problems**. <W2E-002 #103>

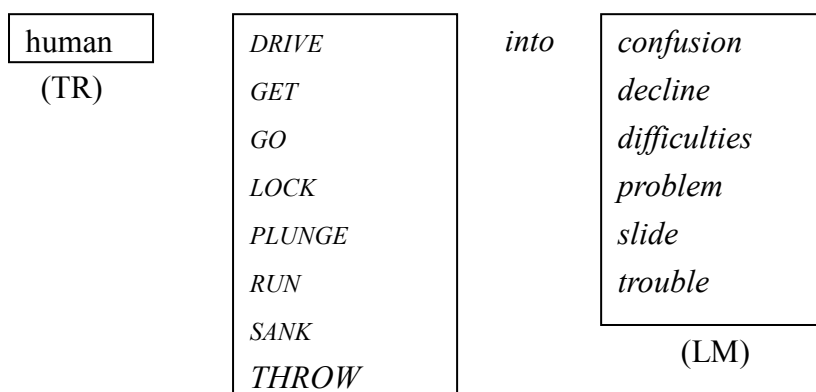

Figure 6.13 Clause pattern of the involvement sense in HA combination

Although the senses in the starting cluster seem similar to the involvement sense, they denote the starting of a neutral state and that of an action. The ‘starting of a state’ sense is found in the idioms whose verb and following noun are distinctive, e.g., *COME into existence* and *COME into office*. The LM is prone to be an abstract noun with no article, such as *being*, *care*, *coma*, *madness*, *possession*, *silence* ((33) and (34)). Thus, such abstract nouns of LM with no article are likely to occur in the sense of the starting of a state. At the same time, the counterpart in the starting cluster, the ‘starting an action’ sense, displays a tendency to fit into a particular pattern of ‘verb + TR + *into ...ing* (LM)’. 41.4% of the senses occur with *into* followed by a gerund, while some nouns denoting an action, such as *action* and *investigation*, also follow the preposition. As a result, it can be concluded that the sense of starting an action is highly likely to be conveyed in the pattern shown in Figure 6.14 below.

- (33) And it was the security needs of the state, which brought the **Ordnance Survey** into being, in seventeen ninety-one, ...<S2B-045 #031>
- (34) **Two-year old Darren** had to go into care when his mother Angela had a mental breakdown. <S2B-038 #106>

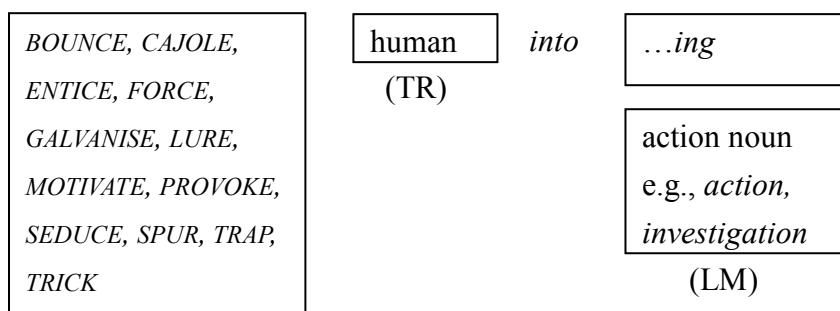

Figure 6.14 Clause pattern of the starting an action sense in HA combination

The ‘concerning or about’ sense, which denotes that the TR’s interest is orientated towards the content of something, also appears to retain a distinctive pattern with particular TRs, LMs and verbs co-occurring. The TR of the sense tends to be a pronoun, which accounts for 78.2% of the occurrences of the sense (36 instances out of 46). Pronouns appear frequently in the conversation register (Biber *et al.*, 2002), as discussed in the account of the encounter sense of the HH combination. It follows that the concerning or about sense may also occur frequently in spoken language. This proposition is supported by the evidence provided by the data that 91.3% of the senses (42 instances out of 46) occur in the spoken register. The co-occurring verb shows a feature of spoken register: such one-syllable verbs as *GET*, *GO*, *LOOK* and *TALK*, which are prone to appear in spoken language, co-occur frequently. The LM is likely to be the noun referring to the content of the story and incident: *area(s)*, *aspect(s)*, *detail(s)* and *reason*. Thus, the data reveal that the concerning or about sense is highly likely to occur frequently in the HA combination (46 instances of 61, 75% of all the combinations) with the pattern emerging as in Figure 6.15 below.

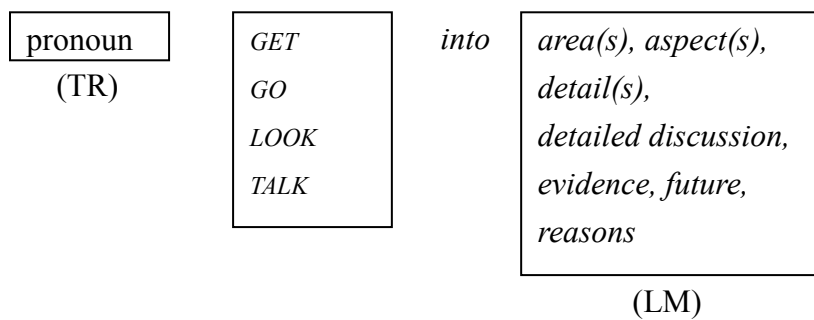

Figure 6.15 Clause pattern of the concerning/about sense in HA combination

6.3.5 AH, CA and AC combination

The AH, CA and AC combinations, occur less frequently than the other combinations (1, 29 and 6 instances respectively), and the distribution of the senses also shows a limited variety. Nevertheless, the linguistic behaviour of the three combinations may imply how the combinations including abstract object as either TR or LM differ from the AA combination whose TR and LM are both abstract objects. Furthermore, the way in which abstract object TR relates to human LM and concrete object LM, and concrete TR to abstract LM, could also be examined.

The configuration based on the AH combination seems unlikely to occur often in the world as we experience it. Supposing that an abstract entity went into a human being, the configuration of the TR and the LM would rarely materialise. There exists only one instance of this combination, as in (35); the configuration becomes effective with the LM considered as a group of people, *organisation*, which functions as a metaphorical receiver of the TR, *issues*.

- (35) ... as responses to changing disease patterns can be heavily shaped by the values of health care decision makers which determine how **new issues** are received into **an organisation**. <W2A-014 #057>

In this section, the CA combination is found more frequently than the other

combinations in question. Based on the fact that the combination of human or concrete object TR and abstract LM occurs more frequently than the reversed combination, such as abstract object TR and human or concrete LM, it could be hypothesised that there is a course of direction in terms of the combinations. In other words, human and concrete objects are prone to be TRs, with the exception of a parallel combination AA, while abstract nouns tend to be LMs. This hypothesis is supported by the result that the AH and AC combinations occur infrequently. The CA combination is found in six derived senses: the senses of the starting cluster, e.g. (36) and (37), those of reflexive, orientation and concerning/about. Compared to the senses in the HA combination, the integration, time and involvement senses are absent in the semantic network of the CA. This may be largely because the senses represent human activity in which a person can be involved and integrated whilst a concrete object cannot.

- (36) The old Irish black horses of the Household Cavalry know the sound of the trumpet and **they** immediately break into a **trot** themselves. <S2A-011 #085>
- (37) Fishing on running water,... and, more importantly here, **baits** come into **fashion** from time to time. <W2D-017 #010>

Having established that the reversed combination is infrequent, there are six instances of the AC combination found in the data. All of them are classified under the penetration sense and they convey the metaphorical movement of an abstract object TR into a concrete LM. As seen in (38) and (39), the abstract TRs, *signal* and *power*, are unlikely to penetrate physically into the concrete LMs, *cable* and *volley*; however, the configurations are expressed by mapping the movement of physical penetration onto the abstract TRs.

- (38) **The UHF signal** that feeds into **the co-axial 75 ohm cable** in Europe should not have too long a run. <W2D-014 #024>
- (39) He has good weight transference to get **power** into **the volley**. <W2D-013 #113>

6.3.6 AA combination

In the account of the CC and HC, the AA combination is hypothesised to occur most in the peripheral senses whose configuration is rarely experienced in an embodied manner. Given that the peripheral senses develop from the central sense through the clusters, Figure 6.16 seems to represent the distribution of the AA combination in the periphery of the senses. More technically, the peripheral senses derived from the ‘reflexive’ and ‘starting’ clusters – ‘change into parts’, ‘metamorphosis’, ‘starting a state’ and ‘starting an action’ – occupy more than half (58.9%) of the instances of the AA combination. However, two counterarguments arise. Firstly, the central sense, ‘penetration’, also occurs equally frequently (30.1%) at the same time. Admittedly, some senses which do not fit into a derived sense of the semantic network have been classified under the penetration sense. As shown in (40) to (42), the phrases containing *into* may fall into the sense of ‘classification’, ‘fitting’ and ‘injection’, since they denote a broader sense than penetration. However, they were classified into penetration for the following reasons: the occurrence is not so frequent as to establish an independent sense and it is likely that the senses to a large extent overlap the penetration sense. Take ‘overlap’, for example; the classification sense is considered to be a topological scene where something goes into the box of a classification. The other refutation is that the HA combination appears with as many peripheral senses in the semantic network as does the AA. As discussed in the account of the HA cluster, the abundance of the peripheral senses may arise from metaphorical mapping onto figurative expressions. Although the mapping seems to happen similarly in the semantic network of the AA combination, the occurrence of the derived senses tends to be isolated in the senses of change into parts, metamorphosis, starting a state and starting an action. In consequence, the hypothesis should be revised to suggest that the combination whose LM is abstract object relates to the peripheral senses of *into* phrases. In order to examine the hypothesis, we explore the four senses of the AA combination.

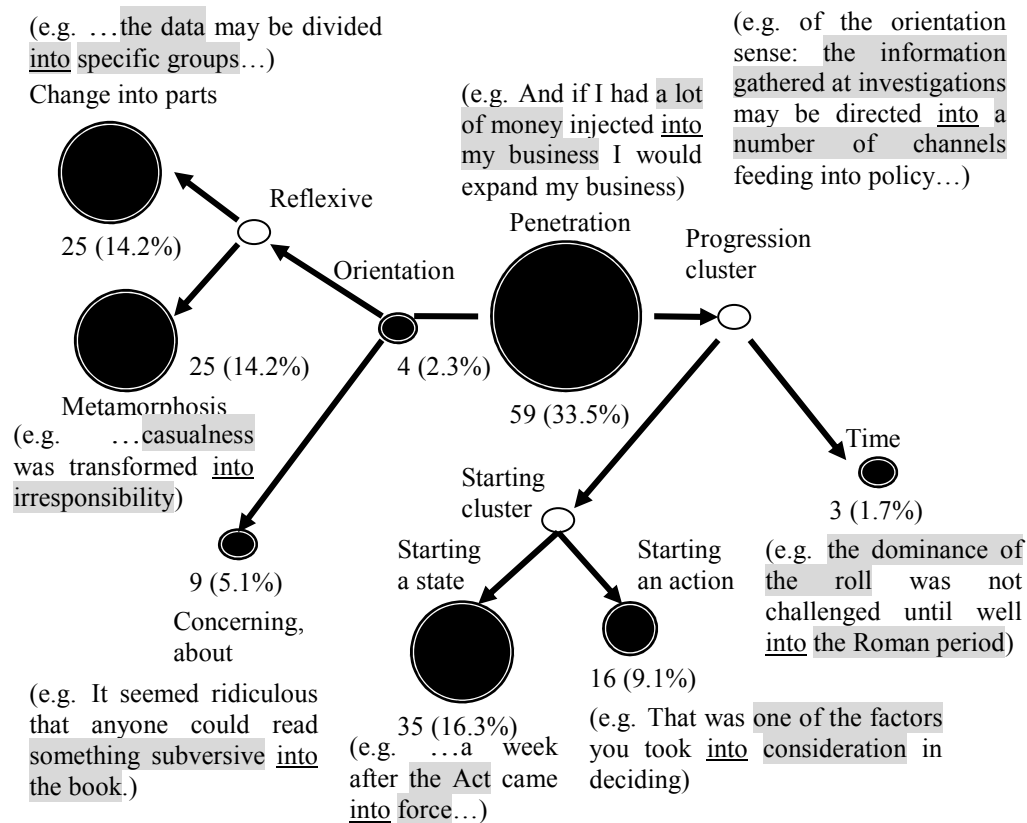

Figure 6.16 Semantic network of AA combination

- (40) Nerve injuries have been classified into various grades and these are discussed below. <W2A-026 #067>
- (41) ... there are recurring features of the best or most-publicized work in AI that are hard to fit into the conventional observation-hypothesis- deduction observation pattern. <W2A-035 #004>
- (42) And if I had a lot of money injected into my business I would expand my business. <S1B-065 #005>

More than half the instances of the starting a state sense of the AA combination co-occur with verb *COME* (51.4%, 18 instances out of 35). The clause pattern containing *COME into* is illustrated in Figure 6.17 below. Some LMs which indicate a launching state, such as *being* and *existence*, are identical with the LM of the sense of the HA combination, while

effect, force and *play* are solely found in the LM of the AA combination. In relation to such LMs, the TR which is expected to be initiated is likely to maintain coherence with the LM. In other words, a human TR, such as a group, can only ‘*come into being*’ or ‘*existence*’, while an abstract object TR such as *regulation, the Act* and *power*, can also ‘*come into effect, force* and *play*’ in addition to the sense of starting the state of being and existence. This finding seems to suggest that the combination of TR and LM may to a certain extent predict what type of words appears in a particular sense.

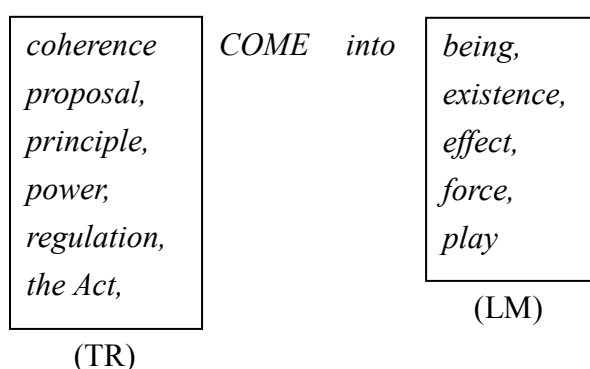

Figure 6.17 Clause pattern of the combination of starting a state containing *COME into* in AA

Particular LMs, *account* and *consideration*, overwhelmingly predominate the instances of the starting an action sense of the AA combination (93.7%, 15 out of 16). The LMs were classified into words indicating an action, on the ground that consideration seems to represent the action of thinking. As regards the structure of the *into* phrase, the idioms appear to form in both the active and passive voices, as in (43) and (44). The inversion of direct object and *into account/consideration* phrase can occur as in (45).

- (43) That was one of **the factors** you took into **consideration** in deciding he was the owner of the vessel. <S1B-063 #201>
- (44) Written guidelines for factory inspectors provide **a basic list of the various factors** to be taken into **account** in making this selection. <W2A-018 #042>

- (45) Part of this legislation will apply in Scotland requiring councils to take into account the race, culture and religion of the child, when choosing carers. <W2C-015 #049>

The co-occurring verb of the change into parts sense of the AA combination is identical with that of the CC which accounts for 33% (18 instances) of all instances of the sense (AA: 46%, 25 instances). The CC and AA combinations occur frequently in this sense, but the HH does so less often. This may imply that a human is not supposed to divide into pieces, while concrete and abstract objects are apt to disintegrate. In addition, the sense was observed infrequently in heterogeneous combinations such as HA and CA. It could be concluded as a result that parallel combinations, such as CC and AA, except for HH, are likely to be prevalent in the change into parts sense, as in (46) and (47).

- (46) Therefore the data may be divided into specific groups which are allocated to a particular colour or shading. <W1A-006 #061>
- (47) One solution to this problem is to merge all available probe data into a single image thereby combining the important features of each individual image...<W2A-036 #046>

The metamorphosis sense of the AA combination shows a variety of TR and LM combination in terms of transition. As in (48) an identical entity is used as the TR and the LM, while the nature of the TR and the LM is totally changed through alternation, as in (49). The co-occurring verb, such as *CHANGE*, *CONVERT*, *DEVELOP*, *EVOLVE*, *GROW*, *MUTATE*, *TRANSFORM* and *TURN*, apparently represents alternation. A distinctive verb, *TRANSLATE*, was found in the AA combination.

- (48) He told his audience that a common currency could evolve into a single currency but only as a result of the choice of governments and peoples and not by imposition. <S2B-017 #043>

- (49) ... but there was a limit beyond which **casualness** was transformed into **irresponsibility**. <W2B-015 #007>
- (50) She has written **several books**, some of which have recently been translated into **English**. <W2D-019 #068>

So far, an analysis of the HCA combination in *into* phrases has been carried out in this section. The following section explores how the results can apply to the establishment of the semantic network of *into*.

6.4 Implications of the HCA combination analysis

The different sections in 6.3 have revealed the distribution of the central and derived senses of *into* phrases in conjunction with the HCA combination of the TR and LM. The analysis is based on the hypothesis that the CC and HC combinations are most likely to be experienced bodily in the conceptualisation of prepositions, while the AA is least likely since it might be difficult to experience the configuration physically. This leads to the second hypothesis: that the CC and HC combinations are found in the central sense, whilst the AA is found in the peripheral senses. To round off the chapter, the following topics are discussed in the light of the results yielded by the analysis of the data:

- Distribution of the HCA combinations and occurrence of the senses
- The central sense of *into*
- Overuse and underuse of the HCA combination
- Radial category and the distribution of the HCA combination

In order to confirm the hypotheses, the HCA combinations were allocated in sequence from the most likely to be experienced bodily (the CC and the CH) to the least likely (the AA)⁸. At the same time, the senses of the *into* phrases were arranged in order from the

⁸ The AH, CA, AC were put into order according to the value of the standard residual (see Table 6.1).

central sense to the peripheral ones. The results are shown in Table 6.13. The figures in the cells represent the frequency of the sense (e.g., 56 instances of the penetration sense in the CC combination), while the figures in brackets show the percentage of combinations of the instances of the sense (56 instances of the CC out of 262 instances of the penetration sense, 21%). The occurrences of the senses and the HCA combination turn out to be distributed diagonally as shown in Table 6.13 below ($r=0.273$, $p<0.01$). This indicates that the CC and HC combinations relate to the occurrence of the penetration sense, while the HA and AA relate to the senses of the clusters of starting and changes of state. It could be concluded as a result that the hypothesis of the relationship between the HCA combination and the central and peripheral senses is to some extent likely to be supported.

senses	CC		HC		CH		HH		HA		AH		CA		AC		AA		sum	
	F	%	F	%	F	%	F	%	F	%	F	%	F	%	F	%	F	%	F	%
P Penetration	56	(21)	94	(36)			3	(1)	35	(13)	1	(0.4)	8	(3)	6	(2)	59	(23)	262	(40.4)
O Orientation	7	(32)	7	(32)					1	(5)			3	(14)			4	(18)	22	(3.4)
C Collision cluster			1	(100)															1	(0.2)
S Affecting surface, embedded	19	(95)	1	(5)															20	(3.1)
M Encounter							6	(100)											6	(0.9)
Progression cluster																				
IN Integration			3	(16)			7	(37)	9	(47)									19	(2.9)
TM Time									5	(63)							3	(38)	8	(1.2)
Retrogression cluster																				
W Withdrawal			2	(100)															2	(0.3)
IV Involvement									20	(100)									20	(3.1)
Starting cluster																				
AC Starting an action									29	(59)			4	(8)			16	(33)	49	(7.6)
ST Starting a state									26	(37)			10	(14)			35	(49)	71	(11.0)
CO Concerning, about			5	(8)					46	(75)			1	(8)			9	(15)	61	(9.4)
Change of state cluster																				
PR Change into parts or pieces	18	(33)					5	(9)	5	(9)			1	(2)			25	(46)	54	(8.3)
MP Metamorphosis	17	(32)					7	(13)	2	(4)			2	(4)			25	(47)	53	(8.2)
	117		113		0		28		178		1		29		6		176		648	(100.0)

Table 6.13 Distribution of the HCA combinations and the senses of *into*

Nevertheless, one question still remains unanswered; namely, which sense, dynamic

penetration or static orientation, is more likely to be central? The figures in brackets in the sum percentage column show how much the sense occupies the instances of the *into* phrases (e.g. 262 instances of the penetration sense account for 40.4% out of 648 instances of the phrases). In terms of frequency, the penetration sense (40.4%) occurs overwhelmingly more frequently than the orientation sense (3.4%). It is argued that frequency does not necessarily prove to be prototypical, given that the sense of a prototype is unlikely to occur frequently (Sinclair, 1991a, Shortall, 2007). However, should it be the case that the prototype of the sense which is highly relevant to the configuration of entities, in this case, preposition, is bodily experienced in the conceptualisation, the CC and HC combinations seem highly likely to be prototypical. Note, in addition, that the penetration sense of the combinations appears to be frequent. Furthermore, the dynamic sense is also found frequently in the HA, CA and AA (34%) in comparison to 57% in the CC and HC. Although the occurrence is not as frequent, the orientation sense shows a similar distribution pattern at the CC, HC, HA, CA and AA. Although the dynamic and static central senses are both evenly used and mapped onto the combinations containing abstract LMs, the penetration sense appears in the HH, AH and AC combinations as well. If it were the case that the central sense is predominant in the semantic network (Tyler and Evans, 2003a), the penetration sense would be more likely to be central, since it appears to be associated with more senses and clusters. As a consequence, I would argue that the dynamic penetration sense is likely to be more central than the static orientation, and the semantic network of *into* could be suggested as shown in Figure 6.18 below.

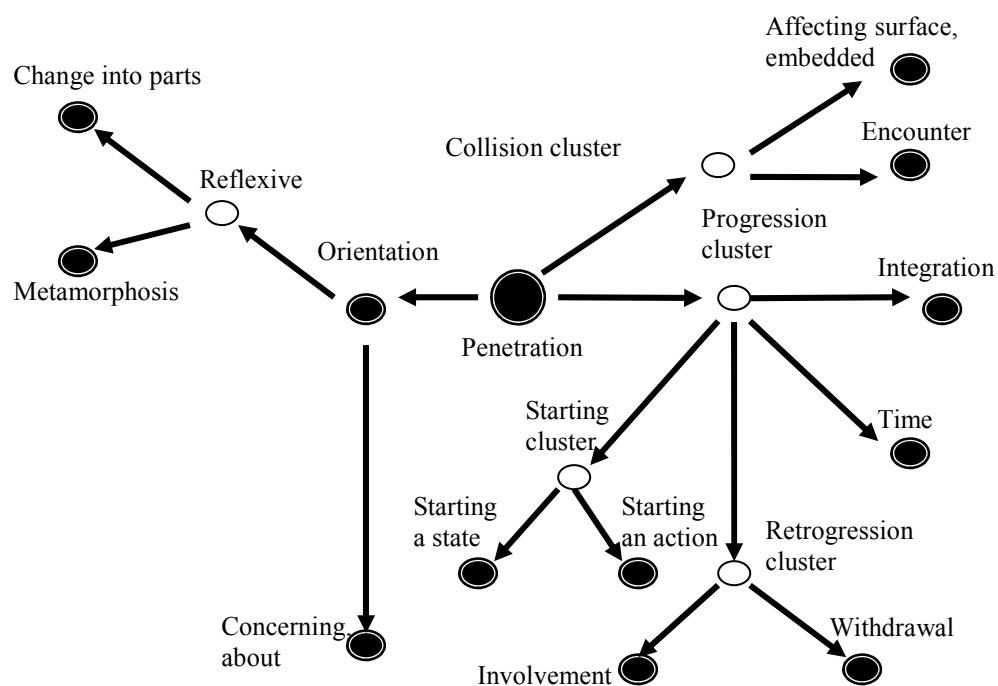

Figure 6.18 Semantic network of *into*

It could be argued that frequency in language represents the entrenchment of a particular use. In this case, a frequent sense could be entrenched in experiences of language and language users might associate it with the surface structure. If so, as illustrated in Figure 6.19 below, it becomes clear how often the senses are experienced in the language use of *into*. This may suggest that the senses of penetration, starting cluster, concerning/about and reflexive cluster are highly likely to be entrenched with *into* through being frequently experienced in language. As a consequence of the distribution analysis, the senses of *into* are likely to be characterised by the central penetration sense and the peripheral derived senses at the same time.

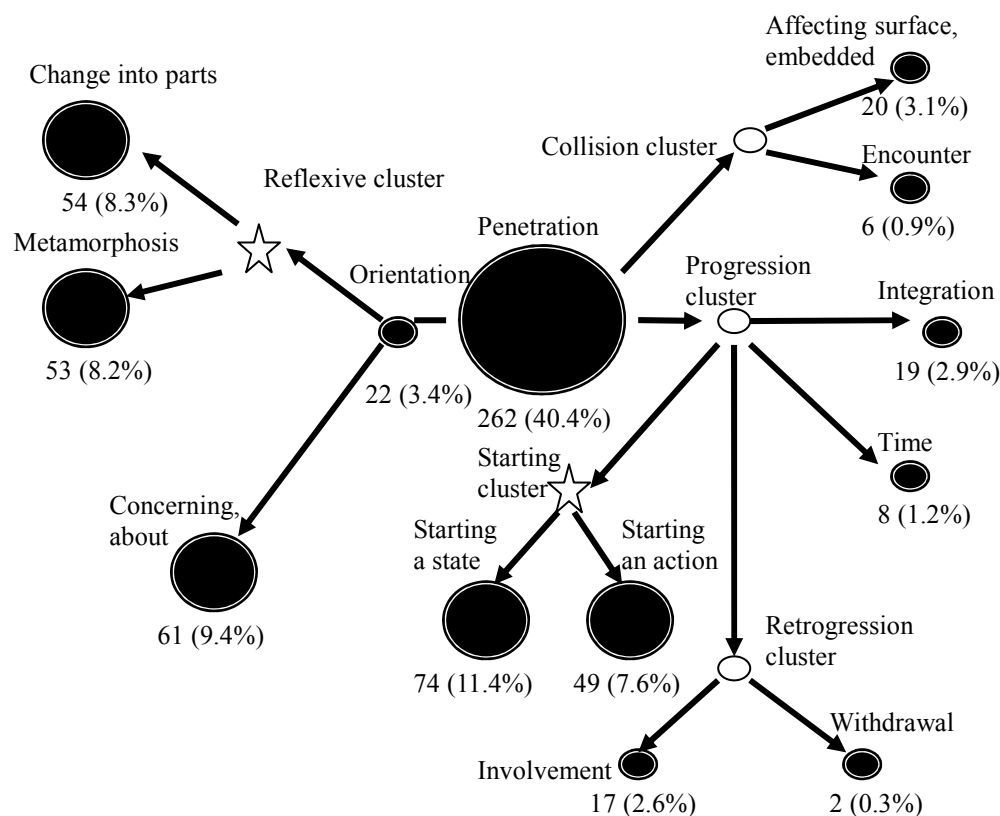

Figure 6.19 Frequency-based semantic network *into*

In terms of the distribution of the senses, the overuse and underuse are statistically significant in accordance with the departure of the standard residuals from the expected distribution. As shown in Table 6.1 above, residual analysis indicates that the HH, CC and AA combinations are overused, while CH, CA, AH and AC are underused. These results suggest that the overused combinations seem to have a parallel relation between the TR and the LM, and the underused combinations might be prone to be heterogeneous, even though the HC and the HA are insignificant. Figure 6.20 indicates the domains in the semantic network in which the individual combinations with HH, CC, AA and HA are frequently found. There is one common feature between the CC and AA: the senses of change into parts and metamorphosis. Those in the reflexive cluster are frequent.

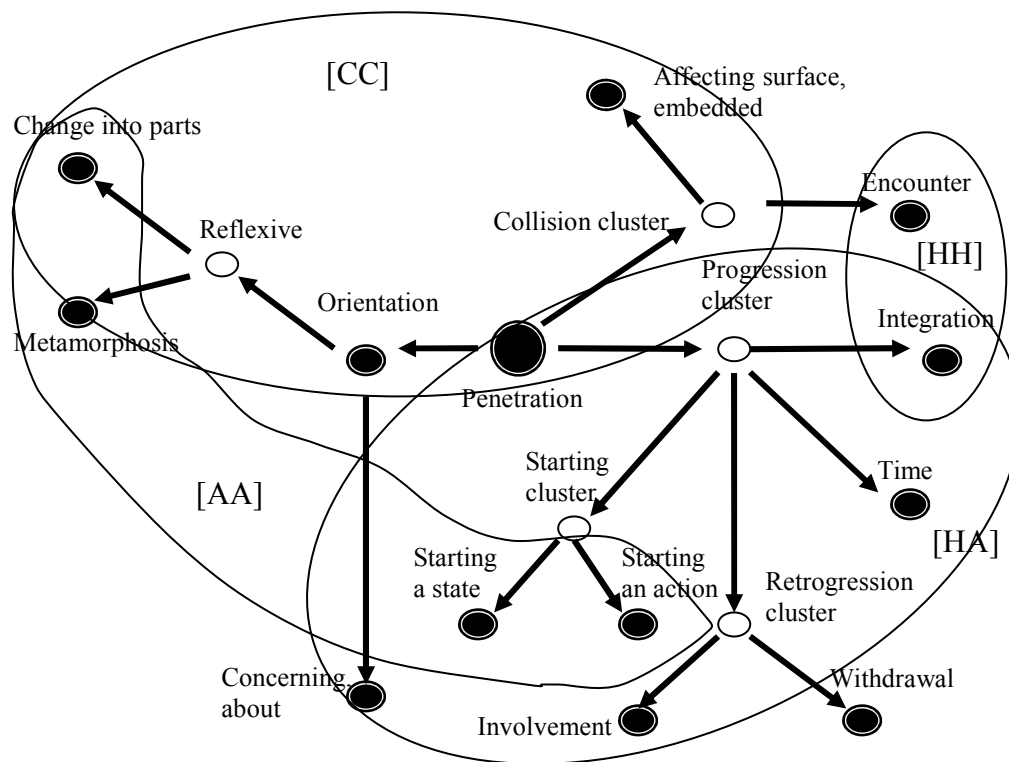

Figure 6.20 Domains of the HCA combinations

A semantic network is assumed to be established in a radial manner in which the subordinate members surround the principal one (cf. 'radial category', Lakoff, 1987). In doing so, the members of the network share certain attributes whereby they are identified as members. The distribution of the senses in the CC and HA combinations are overtly formed into a radial category by centring on the penetration sense which is surrounded by the derived senses (Figure 6.21 and Figure 6.22). In conclusion, the semantic network of *into* (Figure 6.18) is established on the basis that the notion of the radial category and the distribution of the HCA combination are reflected.

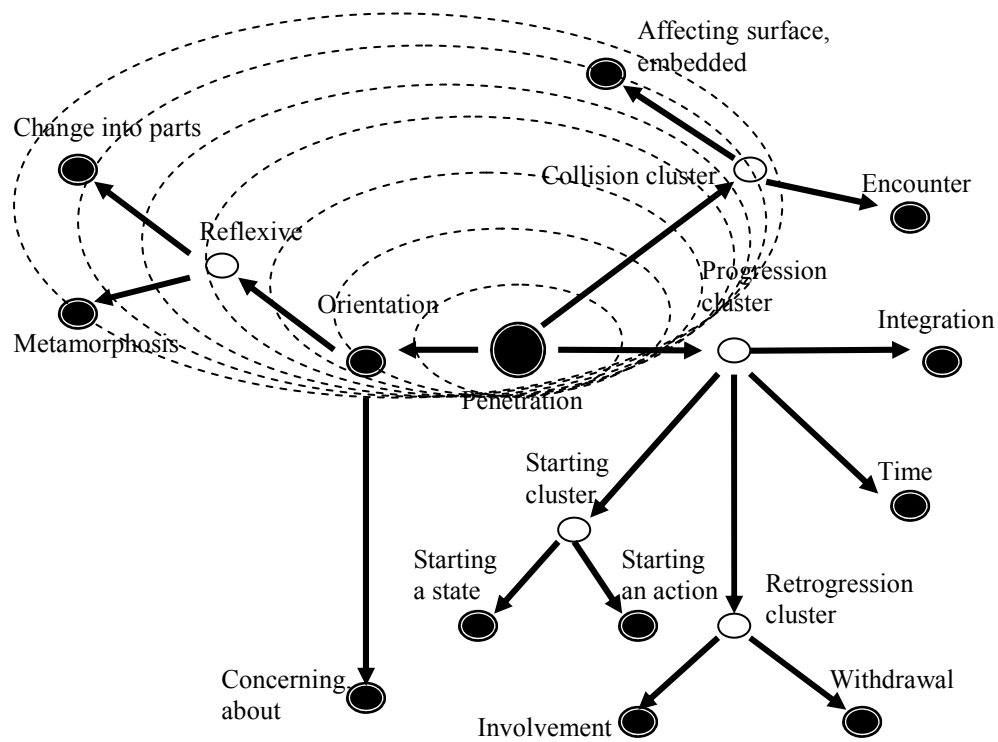

Figure 6.21 Radial category of the CC combination

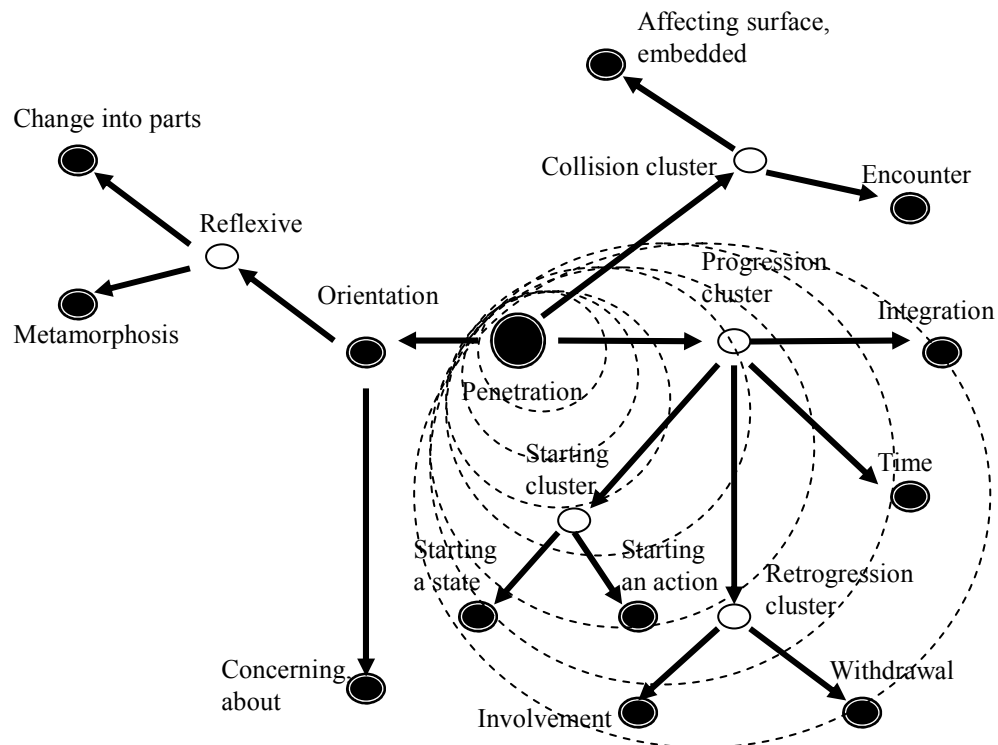

Figure 6.22 Radial category of the HA combination

6.5 Summary of the chapter

This chapter has examined whether the combination of the TR and LM co-occurring with *into* relates to a particular sense of the preposition and attempted to establish the semantic network on the basis of empirical study of the corpus data. The distribution pattern of the HCA combination has suggested that the senses of the preposition are likely to feature the parallel HH, CC and AA combinations. It has also been implied that the distribution pattern of the central and derived senses seem relevant to the HCA combination based on embodied experiences. In the light of the analysis, the semantic network of *into* which is theoretically supported by the evidence of embodiment, radial category and frequency has been established. Most importantly, the result showing that a particular sense of *into* has been observed with a particular HCA combination, verb and clause pattern is likely to lead to the hypothesis that they are to a certain extent involved in the interpretation of *into*, and that the sense is conveyed by their combination.

7. ANALYSIS OF THROUGH

The senses of *over* and *into* have been analysed in the previous chapters. The trajectors [TRs] and landmarks [LMs] which co-occurred with these prepositions were classified into human (H), concrete object (C) and abstract object (A). The empirical corpus data indicate that the HCA combinations clearly tend to associate a particular combination of TR and LM with a particular sense of *over* and *into*. Similarly, the aim of this chapter is to analyse *through*. The reason for choosing this preposition is that the pilot study suggests that it shows a closer distribution pattern of the HCA combination with *over* and *into* than do other prepositions, such as *against*, *at* and *in* (see Chapter 4)¹. In addition, the senses and the mental representation of *over*, *into* and *through* have already been examined comparatively (Lindstromberg, 1998; Tyler and Evans, 2003b). Thus, it seems reasonable to follow the same sequence here.

As has been seen, the hypothesis that a concrete object TR combined with a concrete object LM calls for a spatial sense in prepositions is based on embodied experiences, a theory from cognitive linguistics, which accounts for the close relationship between physical experience and conceptualisation. On this I base my hypothesis that the combination of physical TR and LM is likely to co-occur with a physical sense of the preposition, while the combination of abstract TR and LM will co-occur with a metaphorical sense. I would also argue that the concreteness and abstractness in terms of the nature of the TR and the LM can explain and predict the polysemy of the preposition.

The aim in this chapter is the same as in the previous one: to specify a central sense of a preposition (here, *through*) on the basis of the embodied experiences which emerge from the TR and LM of a human (H) and a concrete object (C); and to establish a semantic network

¹ The HCA pattern of *on* appeared in the pilot study to be closer to the patterns of *over* than *into* and *through*. However, *on* is not analysed in this study, in order to be able to compare *over*, *into* and *through*.

of *through* which, extrapolated from the HCA combinations, including abstract object (A), will show how the sense extends from the centre to the periphery.

7.1 Distribution of HCA

423 instances containing the phrase structure ‘verb + phrase with *through*’ and ‘verb + noun phrase (direct object) + phrase with *through*’ were extracted from the ICE GB corpus (cf. Chapter 3 Methodology)². In classifying the TRs and LMs into HCA combinations, it surprised me that almost 25% of the instances with *through* were not followed by a noun phrase, as we can see in (1). If *through* is acting as a preposition, it co-occurs with a following noun phrase. But the *throughs* in the example of (1) does not. It can thus be assumed that they represent adverbial *through*, not prepositional. Table 7.1 shows that the adverbial use of *through* is twice as frequent as that of *over* (as in (2)), and no instance of the adverbial use of *into* was found in the data, since both Collins Cobuild Advanced Learner’s English dictionary and the Oxford Advanced Learner’s English dictionary indicate that *into* is categorized only in the word class of prepositions.

	instances	adverbial use	%
THROUGH	423	105	24.8%
OVER	481	58	12.1%
INTO	648	0	0.0%

Table 7.1 Adverbial use of *through* and *over* in the ICE GB

- (1) Schumacher and a redhead drove through less than a minute ago. <W2F-012 #009>
- (2) Are you going to stay over? <W1B-009 #119>

² This study analysed *through* according to the surface structure, rather than using existing grammatical theories whereby some conflicting instances might have escaped as the instances containing *through* were being extracted.

This suggests that *over* and *through* are often used as adverbs, partly because the mental representations are associated with the TR passing through the LM. But this is not the case with *into*, in that the TR penetrates the LM but does not pass through. There is one plausible explanation for why *through* is infrequently followed by a noun phrase. It is likely that the following noun phrase is covertly indicated in the context and the LM refers to the preceding utterances in an anaphoric manner, as in (3). The TR is *He*, while the LM is absent from the sentence. However the LM of *[h]e could still go through* is indicated in the six sentences before, namely *the second* [round]. It can thus be argued that the distinction between adverb and preposition is not clear-cut because the noun phrase following the preposition can be elided.

- (3) In order for him to proceed to the third round what will he have to achieve in the second bearing in mind he's obviously not going to win it. ... He could still go through to the third ballot. <S2B-008 #197>

As shown in (3), *through* without a following noun phrase can be followed by a prepositional phrase. For instance, 18 instances out of 105 adverbial *through* instances (17.1%) occur with *to* + noun phrase as in (4), while two instances are also found with an *into* phrase and one instance with an *at* phrase, as in (5). *GET* (six instances, 33.3%) and *GO* (seven instances out of 18 instances, 38.8%) are found to co-occur frequently with adverbial *through* followed by a *to* phrase (Figure 7.1).

- (4) ...some Western relief workers have recently got through to this ravaged area, but their supplies have not been enough. <W2C-002 #047>
- (5) Kevin McKay comes through into second place and then James Starling was third. <S2A-009 #119>

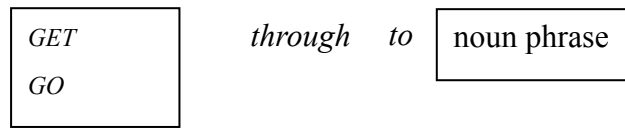

Figure 7.1 Phrase pattern of adverbial *through*

As discussed earlier with example (3), the LM of *through to* phrases can be identified by the context. The TR, *He* and the destination indicated by the *to* phrase are salient in the sentence; however, the covert LM in this sentence alone does not appear, but may already have been mentioned, as in (3), or could be induced from the setting of the utterance. When the LM is not necessarily mentioned and the destination of the TR is made salient, the phrase pattern of *through* + prepositional phrase containing *to/into/at* may occur (Figure 7.2), as in (4), (5) and (6). As a result, a claim could be made, although debatably, that the configuration of TR and LM is established in the mental representation of adverbs as it is with prepositions. In other words, the difference between adverbs and prepositions may lie in whether the LM is salient or not, and the path movement of the TR may be highlighted in terms of adverbial *through*. Nevertheless, we will leave this issue here, since gauging the difference between word classes in grammar and mental representation as a cognitive schema is not the aim at present. This study focuses only on the surface structure of *through* phrases co-occurring with TR and LM.

- (6) Long-suffering holders in Ferranti International saw the shares sink to a new low of 9 1/2p as a line of 3.5m went through at 8 1/2p in what seemed to be a bed and breakfast deal - <W2C-012 #068>

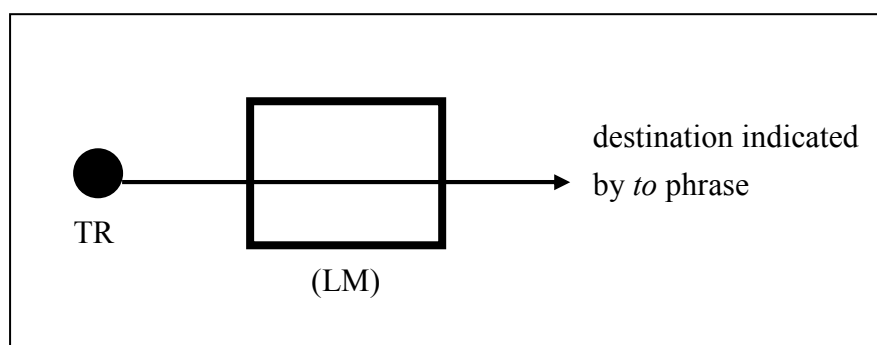

Figure 7.2 Mental representation of the phrase containing *through to* noun phrase

With 105 instances of the adverbial use excluded, the TR and LM of 316 instances containing a *through* phrase were classified as HCA combinations. Table 7.2 illustrates the distribution of the HCA combination of the TR and LM co-occurring with *through*; the distribution pattern appears to be statistically significant ($p < 0.001$). The cell is composed of figures representing four phenomena: the ‘observed frequency’ of the combination in the corpus data; the ‘expected frequency’, which is estimated by the total frequency of row and column cells; the ‘percentage of observed frequency’; and the ‘standardised residual’, which indicates the divergence of the observed frequency from the expected one. The standardised residual is converted from the original residual to the value which is adapted to normal distribution. In this conversion, the value of the standard residual indicates that the absolute value of more than 1.96 and less than 2.58 ($|\text{residual}| > 1.96$), i.e. that it is less than five percent probable ($p < 0.05$); in the same way, $|\text{residual}| > 2.58$ is $p < 0.01$; and $|\text{residual}| > 3.29$ is $p < 0.001$. The plus or minus preceding the standard residual signifies that the combination is overused or underused. In the case of Table 7.2 below, the CC combination is overwhelmingly overused ($\chi = 5.152$, $p < 0.001$), while the CA and the AC are largely underused ($\chi = -3.941$, -3.676 , $p < 0.001$). In comparison, the AH and AA are found to be overused, but to a smaller extent ($\chi = 2.562$, 2.112 , $p < 0.05$). Table 7.3 and Figure 7.3 illustrate the distribution pattern of the HCA combinations of *through* in the data of the pilot

study, the extract from the Bank of English and the present data of the ICE GB corpus. Although the over-/underuse of the HC and AH differ to some extent, the whole distribution pattern of the HCA combination turns out to be rather similar, in terms of such peaks as the HA, CC and AA and such troughs as the CH, CA and AC. This suggests that a similar distribution pattern of the HCA combination of *through* can be seen in the two different corpora. It should, however, be noted that the overused AH of the ICE GB, which differs considerably from the pilot study, will be scrutinised when analysing the instances in the following section.

		LM			
		H	C	A	
TR	H	Frequency	18	66	93
		Expected Freq	21.3	72.8	82.9
		%	5.7%	20.9%	29.4%
		Std. Residual	-0.712	-0.799	1.109
	C	Frequency	3	54	9
		Expected Freq	7.9	27.2	30.9
		%	.9%	17.1%	2.8%
		Std. Residual	-1.752	5.152	-3.941
	A	Frequency	17	10	46
		Expected Freq	8.8	30.0	34.2
		%	5.4%	3.2%	14.6%
		Std. Residual	2.562	-3.676	2.112



$\chi^2 = 72.667$ d.f. = 4 $p < 0.001$  Overused  Underused

Table 7.2 HCA distribution of the TR and LM of *through*

	HH	HC	HA	CH	CC	CA	AH	AC	AA
Pilot Study	1.498	-2.306	1.725	-1.147	4.215	-3.777	-0.718	-2.237	2.537
ICE GB	-0.712	-0.799	1.109	-1.752	5.152	-3.941	2.562	-3.676	2.112

Table 7.3 Standard residuals of HCA combinations containing *through* in the pilot study and ICE GB

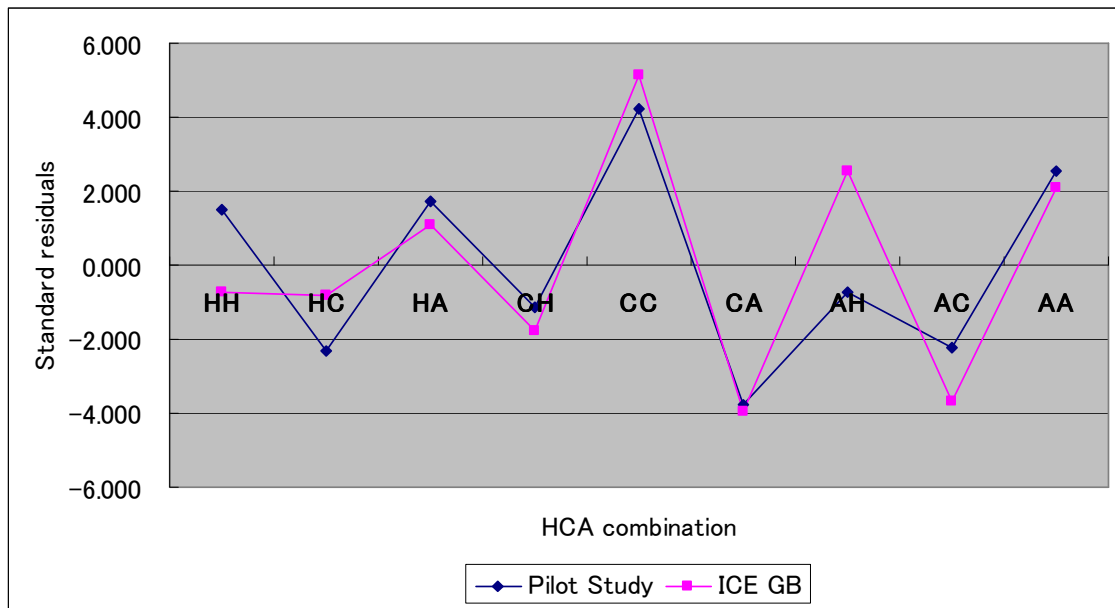

Figure 7.3 Distribution pattern of Table 7.3

Table 7.4 and Figure 7.4 below show the residuals and the distribution pattern of the HCA combinations with three different prepositions, *over*, *into* and *through*. On the whole, the residuals indicate that the CC and AA are overused and the CA and AC underused, although it is also true that the residuals of *into* are overused in the HH and underused in the CH and AH. This general pattern suggests that, although the distribution patterns of the three prepositions are similar, *over* and *through* in particular show approximately the same pattern. The lines of *over* and *through* in Figure 7.4 illustrate the similarity of the distribution patterns. On the basis of this finding, it could be hypothesised that the path movement of the TR may relate to the distinct distribution patterns. In other words, the TR of *over* and *through* passes through the top and the body of the LM, while that of *into* penetrates into the LM but does not follow a path through it. In conclusion, the HCA combinations to a certain extent succeed in identifying the differences between the three prepositions. Hence, the following sections qualitatively examine the relation between the HCA combinations and the central and derived senses of *through*.

	HH	HC	HA	CH	CG	CA	AH	AC	AA
OVER	0.118	-0.072	0.020	-0.932	3.830	-3.116	-0.754	-3.779	3.137
INTO	3.641	-0.419	-0.674	-2.558	8.785	-6.177	-2.515	-7.294	6.406
THROUGH	-0.712	-0.799	1.109	-1.752	5.152	-3.941	2.562	-3.676	2.112

Table 7.4 Residuals of *over*, *into* and *through* and the significance of overuse and underuse

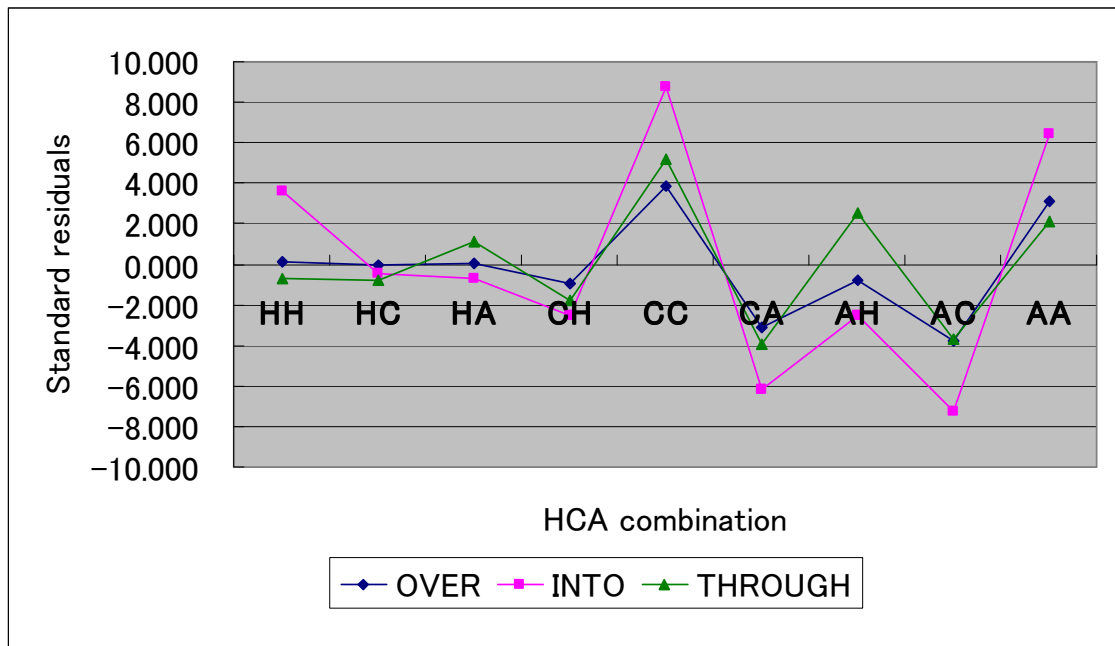

Figure 7.4 Distribution pattern of Table 7.4

7.2 Central and derived senses of *through*

7.2.1 Mental representation of the central sense of *through*

The central sense of *through* is examined in relation to previous work on the ‘prototype’ concerning the ‘proto scenes’ (Tyler and Evans, 2003a: 50), configurations closely related to embodied experiences. As we saw in Chapter 2, these schemas highlight different aspects of the spatial configuration of the two entities involved. A prototype is the best representative, the most basic instance, of the members of a category. In terms of prepositions, the simplified mental picture of the prototype has been represented by diagrams which linguists devise intuitively (Dirven, 1989; Quirk *et al.*, 1985). As illustrated in Figure 7.5, the prototype of *through* (or what Dirven (1989) calls the ‘basic concept’) has also been used to exemplify a wide variety of spatial concepts mediated by *through*, including the metaphorical senses. In

contrast, a proto-scene focuses on the relationship between the trajector (TR) and the landmark (LM) (Langacker, 1987; Tyler and Evans, 2001, 2003a, 2003b). The spatial configuration of TR and LM has also been defined as a type of ‘image schema’ which emerges from embodied experiences (Evans, 2007a). Taking the premise of the proto-scene, I would argue that the combination of the TR and the LM which is most often bodily experienced tends to be perceived as the most central and the central configuration may relate to the central sense of the prepositions. My findings in earlier chapters have raised the issue of ‘prototypicality’, because this has been found to operate along two distinct yet related continua between the combination of TR and LM and the senses.

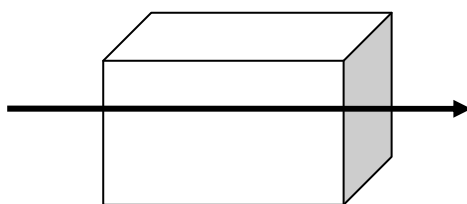

Figure 7.5 Mental representation of *through*

The spatial configuration of *through* has been compared to that of *over* (Dirven, 1989; Lindstromberg, 1997) since both prepositions are assumed to entail path movement from one place to another. However, the movement of *through* and *over* follow two distinctive courses: as shown in Figure 7.5 above, the path of the former which follows the trajectory of the TR traverses the inside of the LM (‘path as tunnel’ in Dirven, 1989: 521), whereas the TR of the latter traces a path above the LM without penetrating the LM (‘path as route’, *ibid.*: 521). The course of the path movement can be divided into three parts – starting point, midpoint adjacent to the LM and end point. Regarding these referential points, the midpoint of *through* on the inside of the LM is distinct from that of *over* which is on the outside of the LM. In conclusion, as is often the case with the prepositions related to path movement, the TR

is assumed to be an entity which can travel to the LM, while the LM is an entity which allows the TR to traverse the inside of an area and a volume (Dirven, 1989; Lindstromberg, 1998).

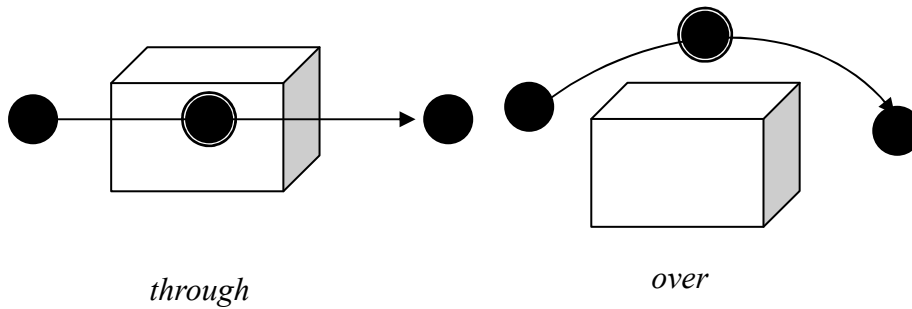

Figure 7.6 Referential points of *through* and *over* (adapted from Dirven, 1989: 521)

The difference between *through* and *into* seems to arise from whichever part in the TR's trajectory, its mid- or end-point, is 'salient'. Example (7) illustrates a spatial relationship of *through* between the TR, *that jab*, and the LM, *his guard*, where the LM represents the mid-point of the TR's movement, but not the destination. Technically speaking, the end-point of the TR's movement can be identified, since the end-point, *the face*, is covertly specified, in that the TR, *that jab*, hits *the face* (Figure 7.7 below). By contrast, the TR's end-point is highlighted by *into*, such that *that jab* thuds into *the face*, as in (7). For the same reason, the LM serves as the end-point of the TR in the configuration of *into*. Again, take example (8): the TR remains on the inside of the LM, *the tea leaves* in *the cups*, but the TR is supposed not to go outside of the LM to *the table*.

- (7) "But Mason made no mistake,... but just a little bemused there as **that jab**, came thudding **through his guard** again and **into the face**." <S2A-009 #084>
- (8) Miriam paused in the act of pouring boiling water on **the tea leaves** spooned **into the cups** on the table. <W2F-007 #110>

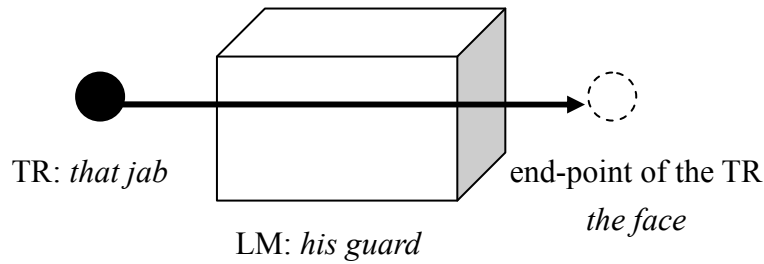

Figure 7.7 Spatial configuration of Example (7)

As noted in connection with *over* (Chapter 5), the proto-scene of *over* is a static configuration in which the TR hovers above the LM in the sphere of the mutual effect (cf. Chapter 5, Figure 5.3 above). This is because there is a suggestion that the proto-scene is uncomplicated, having a single ‘functional element’, but this would not discount altogether the possibility of having more than one element (Tyler and Evans, 2003a). Although the proto-scene of *over* suggested by Tyler and Evans (ibid.: 66) is static, my findings in Chapter 6 show that the proto-scene of *into* is almost always dynamic. In the same way, the static TR at a certain point in the course of the path would not represent the whole of the configuration mediated by *through*. For example, in the phrase of *halfway through* the TR does not complete the path represented by the LM (see page 250 and 251). Consequently, it can be inferred that the path trajectory of the prepositions in question may derive from the dynamic, not the static, movement of the TR.

7.2.2 Derived senses of *through*

The previous section concludes that the central sense of *through* is based on the configuration of the path movement in which the TR traverses the inside of the LM, coming to rest at an end-point on its outside. Lindkvist’s comprehensive work (1976) on the locative senses of *through* shows that it is the dimensional features of the LM which give rise to the derived senses. As shown in Table 7.5 below, sense 1 indicates an area or a volume as the LM, as in

(9) and (10). Even a point which seems not to retain a space through which the TR goes, is designated as the derived sense 3, as in (11). Furthermore, sense 5 suggests that a group of people or things can be the LM of *through*, as in (12), despite the fact that the constituents, such as persons, do exist independently and are not physically merged with each other. As discussed in Chapter 5, such varieties in the dimension of the LMs are probably due to ‘image schema transformations’ (Dewell, 1994; Kreitzer, 1997; Lakoff, 1987a), which allow us to perceive different forms of a single entity so that the language construes the entity. The spatial configurations of (9) to (12) and the traversal sense would be identical provided that the transformations encouraged us to construe them as bounded LMs.

1. Passing through a channel, opening or medium
2. Piercing through a substance
3. Through a point
4. Distribution or activity carried through a whole extent or to the end
5. Through a collective and plurality
6. Perfective implication

Table 7.5 Senses of *through* by Lindkvist (1976)

- (9) I think it [the route] actually goes through Brussels, doesn't it, the motorway. <S1A-021 #197>
- (10) But, doesn't it [the photon] have to go through all the other cells first because of the arrangement. <S1B-015 #090>
- (11) ... to discover a US military vehicle racing through the checkpoint and away from a group of US soldiers... <W2F-012 #138>
- (12) “Well, if you look at my fingers when light is shone through them [the fingers], they're predominantly red.” <S2A-053 #001>

As examined in section 2.4, the ‘conduit metaphor’, which is associated with the

transfer of ideas and feelings, underlies a number of expressions in English (Day, 2000; Grady, 1998; Reddy, 1979). *Through*, in particular, is reflected in metaphorical transfer by a ‘channelled’ means, which leads to the agent, instrument and reason (Dirven, 1989). As was seen in section 6.2.3, a comparative study of twelve prepositions (Dirven, 1993, cf. Table 6.5, p 196) illustrates that the semantic extensions of prepositions are (a) space, (b) time, (c) state, (d) area, (e) manner, (f) circumstances and (g) cause. Of these, (c), (d) and (f) are not found in the extensions of *through*. As a consequence, a plain network of *through* has been suggested, as shown in Figure 7.8. This suggests the elements of *through* from the central sense to the derived ones: namely, that ‘enclosure’ at the pivotal point of the extension indicates the boundedness of the LM; the ‘channel’ of the derived senses is likely to refer to the movement of conduit and path which is reflected in the metaphorical extension.

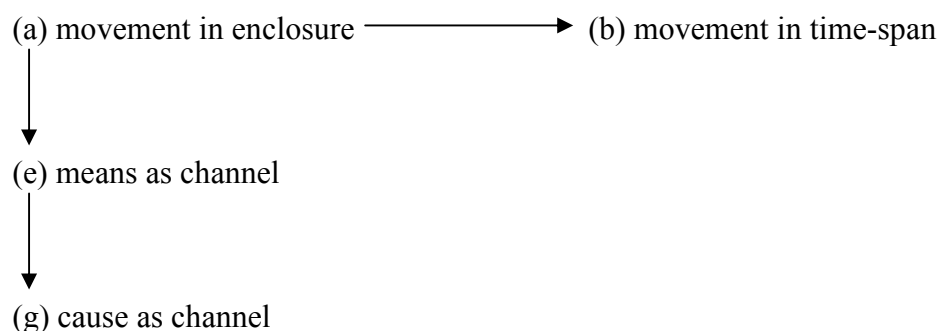

Figure 7.8 Radial network of extensions of *through* (Dirven, 1993: 82)

Tyler and Evans (2003a) provide an account of the senses of *through* by classifying them into ‘metaphorical senses’ and others, which seems to advocate the mapping of the spatial configuration onto abstract ones (Table 7.6 below). Despite the elaborate listing, the dichotomous grouping of the senses of *through* can be amplified by adding other senses. Corpus evidence from this study will be used later to provide a revised list of the senses. In the list provided by Tyler and Evans (2003a), some of the senses correspond to those proposed

by Lindkvist (1976) and Dirven (1989, 1993), while the ‘on-the-other-side-of’ sense is suggested in the account of Tyler and Evans (2003). The distinctive sense is examined in my analysis of *over* (cf. section 5.3.1) and is found to derive from the ‘A-B-C trajectory’ which crystallises the path movement of *over*. Likewise, the path movement of *through* can give rise to the on-the-other-side-of sense, although the mid-point is located inside the LM, unlike the mid-point of *over*, which is above the LM, as shown in Figure 7.6 above. For example, the success sense of *through* metaphorically infers that the TR is at the end-point of the path movement, as in *but like I’m just going through the course*. <S1A-034 #015>.

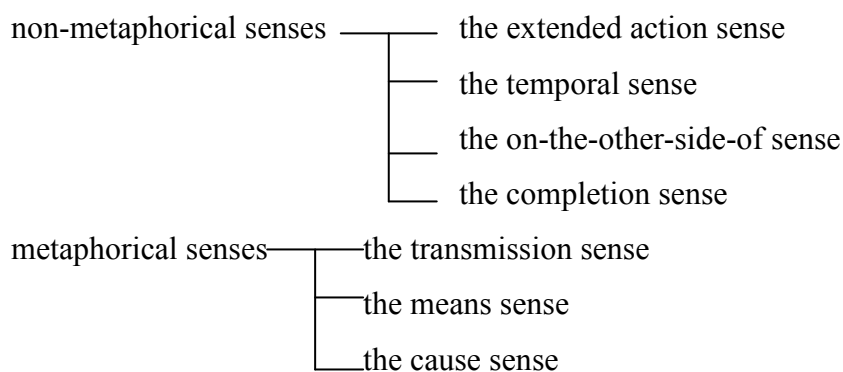

Table 7.6 The senses of *through* suggested by Tyler and Evans (2003a)

It can thus be concluded that the spatial configuration of *through* can be established with the LM, which is construed as bounded by the transformations of schemas. And the spatial configuration related to path movement is highly likely to develop into metaphorical senses. The next section explores the way in which the combination of TR and LM is associated with the central and derived senses of the preposition.

7.3 HCA classification of *through*

The analysis in the previous chapter reveals a weak but statistically significant correlation between the HCA combination and the senses of *into*. This section will adopt the same

methodology, taking the hypothesis that a combination which can be bodily experienced, such as CC (concrete object TR and concrete object LM) and HC (human TR and concrete object LM), is the central sense, while a combination composed of abstract entities, such as AA (abstract object TR and abstract object LM), is often found in the peripheral, metaphorical senses. The results are illustrated in Table 7.7. Note that the percentage column of the sum shows the proportions of the senses of all the instances of *through* phrases, while the figures in brackets indicate the percentage of the HCA combinations in a particular sense. For example, the traversal sense in the CC combination accounts for 34 instances (41% in brackets, out of all 82 instances of the sense), while the 82 instances of the traversal sense take up 25.9% of all the 317 instances containing *into*. In the following section, we explore the distribution of the senses in each HCA combination.

senses	CC		HC		CH		HH		HA		AH		CA		AC		AA		sum	
	F	%	F	%	F	%	F	%	F	%	F	%	F	%	F	%	F	%	F	%
T Traversal	34	(41)	35	(43)	2	(2)	1	(1)	1	(1)	1	(1)			4	(5)	4	(5)	82	25.9
A-B-C trajectory cluster																				
PR Protusion	3	(100)																	3	0.9
OS On-the-other-side-of			6	(55)					4	(36)							1	(9)	11	3.5
TM Temporal									9	(47)			2	11			8	(42)	19	6.0
EXP Experience									21	(100)									21	6.6
CV Covering	7	(44)					1	(6)			1	(6)	1	6	2	(13)	4	(25)	16	5.1
EX Examining			15	(38)			1	(3)	24	(60)									40	12.7
Impediment duster																				
OB Obstacle	3	(33)	1	(11)					2	(22)							3	(33)	9	2.8
SC Success									5	(83)			1	17					6	1.9
Effect cluster																				
BM By means of	7	(11)	9	(15)			1	(2)	20	(33)	4	(7)	2	3			18	(30)	61	19.3
MS Make someone do					1	(4)	14	(54)			11	(42)							26	8.2
BO Reason, because of									7	(32)			3	14	4	(18)	8	(36)	22	7.0
	54	(17)	66	(21)	3	(1)	18	(6)	93	(29)	17	(5)	9	(3)	10	(3)	46	(15)	316	100.0

Table 7.7 Distribution of the HCA combination and the senses of *through*

7.3.1 CC and HC combinations and the central sense of *through*

As noted in Chapter 7, the central sense of *into* frequently occur with the CC and HC combination, which represent the spatial configuration between the TR and the LM, since it

can often be bodily experienced. However, at the same time, the combinations also appear in substantively metaphorical senses, such as the change of state senses in the case of *into*. Can such a polarised distribution of the central and peripheral senses also be seen in the instances of *through*? Table 7.8 below shows that the CC and HC combinations are seen in the central sense, ‘traversal’, as in (14) and (20) below, and the peripheral ‘by means of’, as in (33) below and (13), suggesting that the polarised distribution of the senses is identified in conjunction with the combinations of *into* and *through*. More importantly, the distribution pattern of the senses in these combinations appears to be similar, resulting in similar semantic networks. As shown below in Figure 7.9 and Figure 7.10, both networks have a high proportion of the ‘traversal’ sense, as well as the ‘covering’ and the peripheral ‘by means of’ sense. We next consider each sense and its instances in turn.

senses	CC		HC	
	F	%	F	%
T Traversal	34	63.0%	35	53.0%
A-B-C trajectory cluster				
PR Protrusion	3	5.6%		
OS On-the-other-side-of			6	9.1%
CV Covering	7	13.0%	15	22.7%
Impediment cluster				
OB Obstacle	3	5.6%	1	1.5%
Effect cluster				
BM By means of	7	13.0%	9	13.6%
sum	54	100.0%	66	100.0%

Table 7.8 Sense distribution of *through* in the CC and HC combinations³

- (13) All the things which occur around you, and you sense through your eyes, your ears, your feeling... <S1B-016 #121>

³ Unlike Table 7.7, the percentages in Table 7.8 indicate the proportion of the senses either in the CC or the HC combination.

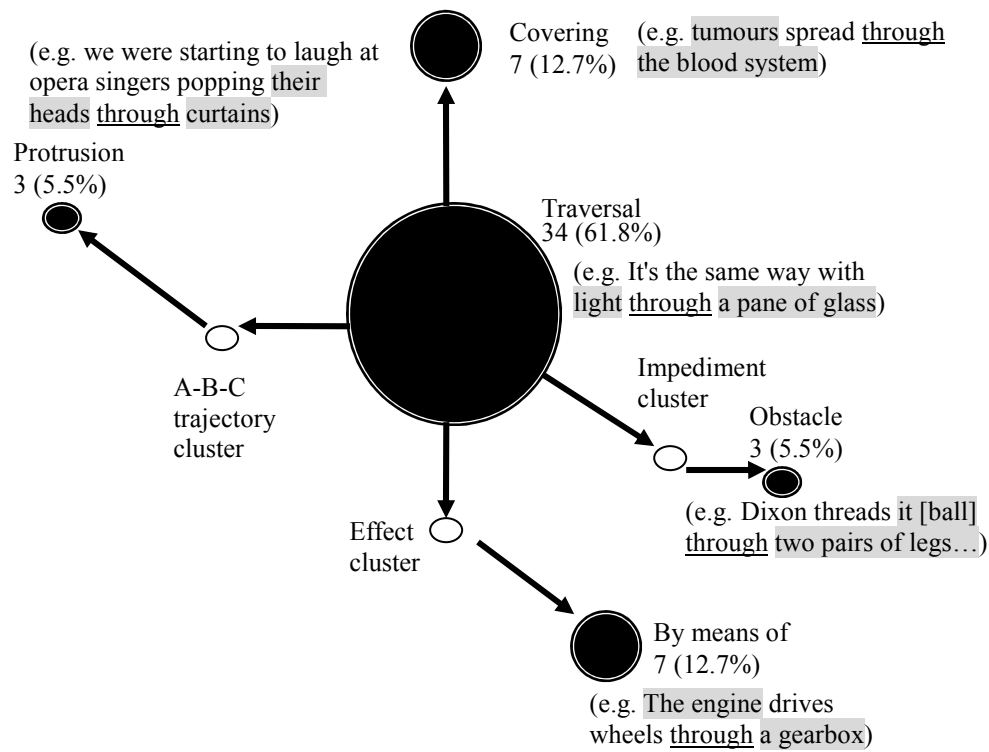

Figure 7.9 Semantic network of CC combination

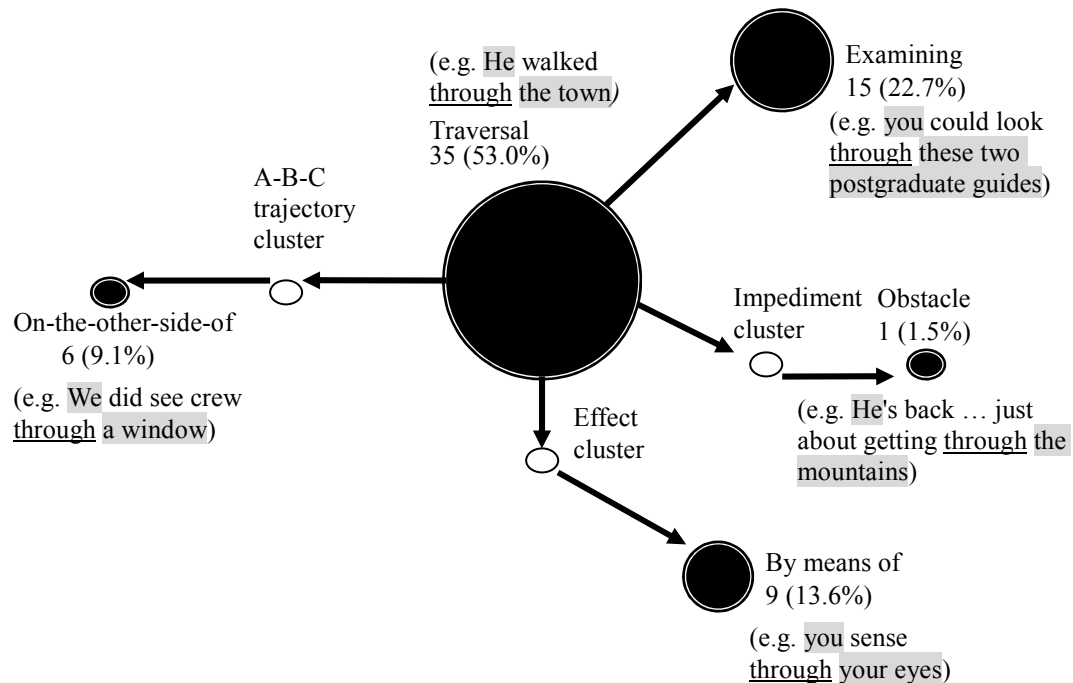

Figure 7.10 Semantic network of HC combination

Traversal

The ‘traversal’ sense is likely to be the central sense of *through*, since the spatial configuration in which the TR passes from one end to the other of the inside of the TR and reaches the outside can often be experienced bodily. Recurring experiences through our five senses are considered to help the conceptualisation of spatial configurations: for example, in (14), as we experience a *ball* passing along a *channel*, we formulate and associate the concept of *through* with the spatial configuration. The sense occurs frequently with the CC and HC combinations; as many as 84% of instances (34 instances of the CC and another 35 instances of the HC, 69 in total, out of 82 instances of traversal) were found in the data. This seems to suggest that the central sense, which symbolically represents the path movement of *through*, occurs most frequently in the CC and HC combinations. The trends correspond to those of *into*, as seen earlier in Chapter 6. With *over*, which is also based on the concept of path movement, the HC combination was found to occur frequently in its central sense.

- (14) Ray Woods dinks it [the ball] through the inside right channel here towards Stewart Robson. <S2A-017 #094>

Although the traversal sense occurs frequently with the CC and HC combinations, the co-occurring TR and LM and verbs illustrate the different patterns. Regarding the CC, the concrete object as TR represents something which steers a straight trajectory: ‘*light*’, ‘*sun*’ and ‘*radiation*’ as in (15) to (17), which were found in 12 instances (35%, out of 34 instances of the traversal sense in the CC). However, in terms of the HC, it is unlikely that the human and the animate as TR will necessarily follow a straight trajectory; rather, the TR moves flexibly as *monkeys* do, as in (18).

- (15) It's the same way with light coming through a pane of glass. <S1B-015 #097>

- (16) It's a tall narrow building ... and today filled with, all sorts of other brightness

of colour as well as the sun streams through its magnificent stained glass windows. <S2A-020 #109>

- (17) If it is damaged (by thinning or by puncture), more UV radiation would pass straight through the atmosphere. <W2A-030 #030>
- (18) One can accept that monkeys occur in the treetops – after all we are brought up with the image of monkeys swinging through the branches... <W2B-021 #060>

The CC and the HC in the traversal sense appeared to a large extent to have verbs in common. While *COME*, *GO* and *PASS* were found in both combinations, *RUN* and *SEND* occur only in the CC, while *WALK* occurs only in the HC. These distinctive verbs are likely to associate with the nature of the TR in the combinations. For instance, *RUN* is used to describe the movement of the inanimate – that is, the concrete – object TR, but *WALK* is not and therefore the verb was found only in the instances with human TRs.

- (19) They go out into the moonlight on the Mount of Olives up the Kidron Valley that still runs through Jerusalem... <S2B-028 #109>
- (20) He walked through the town giving out blessings and absolution to all sinners. <S2B-027 #067>

The LM with *through* has been concluded earlier as being subject to transformations by human construal. As discussed by scholars (Dirven, 1989; Tyler and Evans, 2003a), it should be a bounded entity, as in (21). Nevertheless, the transformations are likely to allow us to construe a non-bounded entity as if it were bounded. The instances of the data illustrate that an area, such as *city*, which is not physically enclosed, can in fact be considered as bounded, as in (22). Likewise, a point which seems to have no volume can be also construed as the LM of where the TR passes: *door* was found as the LM in a certain number of instances, as in (23). Strictly speaking, the ‘door’, which metonymically refers to the doorway, is unlikely to retain

the sense of a space which someone gets into and then out of. Two reasons could be suggested. It appears that the foregrounding of the path movement may give rise to the transformation. In other words, the travelling of the TR from one side through the LM to the other is probably more important than whether the LM retains a space or not. Otherwise, the image schema transformation (Dewell, 1994; Kreitzer, 1997; Lakoff, 1987a, cf. 7.2.2 above) may contribute to such a flexible construal.

- (21) But doesn't it [the photon] have to go through all the other cells first because of the arrangement. <S1B-015 #090>
- (22) Those Iraqi supply lines pass through the city of Basra location of Saddam Hussein's southern command headquarters... <S2B-001 #044>
- (23) I mean Ken Russell was expected to walk through a door before you. <S1B-045 #090>

Also, our perception can be transformed in the same way as, when independent entities gather, the aggregate is seen as one volume (multiplex mass, cf. Chapter 6.2.2). Examples (24) and (25) show that independent *hands* and *trees* are construed as bounded LMs by the metonymic transformation that the space between *hands* and *trees* is seen as part of the LMs. Tyler and Evans (2003a) argue that the LMs of both *through* and *into* are bounded. However, my data indicate that such 'mass to multiplex transformation' was not found in the LMs of *into*. This seems to mean that the boundedness of *through* is distinct from that of *into*. To encapsulate the traversal sense, the phrase patterns of the CC and HC in the central sense can be illustrated as shown in Figure 7.11 and 7.12 below.

- (24) ... and it [the ball] goes through the hands of Stevenson who ran off the boundary. <S2A-013 #006>
- (25) There is a whole range of monkey species in the jungles of the Celebes, ... where a real delight is to watch a troop of langurs swing through the trees.

<W2B-021 #021>

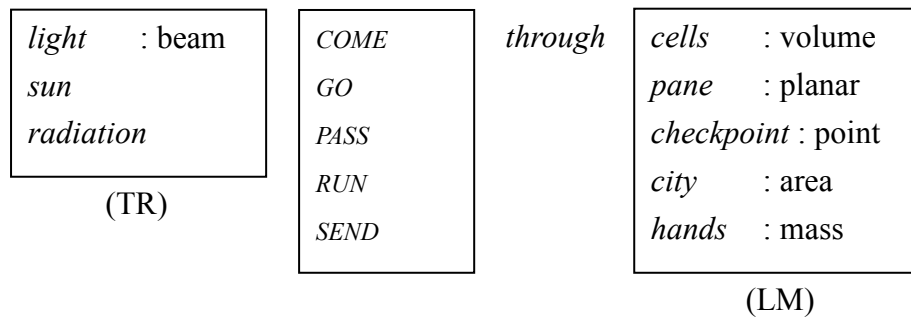

Figure 7.11 Clause pattern of the traversal sense in CC combination

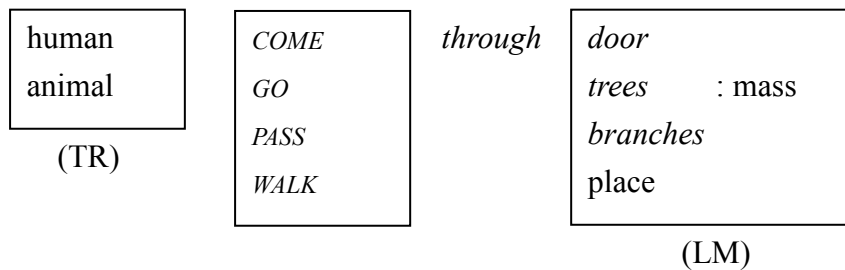

Figure 7.12 Clause pattern of the traversal sense in HC combination

On-the-other-side-of

The sense of on-the-other-side-of was also seen in one of the senses of *over* (cf. Chapter 6) and it is assumed to emerge as a result of path movement. As in [t]he cat jumped over the wall (Tyler and Evans, 2003a: 9), the focus point is at the place, *the cat*, behind the LM, *the wall* and therefore the result of the path movement is foregrounded in this use of *over*. Likewise, as regards the on-the-other-side-of sense of *through*, the point on which the speaker focuses is the end-point of the TR's path movement, for example in (26), *a couple of duty crew*, not the LM, *a window*. Collins Cobuild Advanced Learner's Dictionary (2003: 1512) introduces this as a sensory sense, mentioning that "if you see, hear, or feel through something a particular thing", the visual and auditory senses are involved, as in (27) and (28), and in fact what they see and name is not the LM, but the things behind it. The difference in the

on-the-other-side-of sense between *over* and *through* lies in the route of the TR movement, in other words, in whether the TR traverses the inside of the LM or not. Although the end-point of the path results in the same place on the other side of the LM, *through* still represents the traversal of the TR.

- (26) We did see a couple of duty crew through a window. <S1A-021 #088>
- (27) So this is the front and this is the back so it's kind of [you are] looking at a section through the neck. <S2A-056 #034>
- (28) 'I called through the door last night, but you didn't say anything.' <W2F-001 #163>

Through has another type of on-the-other-side-of sense. It denotes completion of an activity when it co-occurs with 'halfway', as in (29) and (30)⁴. As was the case in the on-the-other-side-of sense, the completion sense was also found in the senses of *over*. It can be again implied that the path movement based on *through* and *over* shares the same features in its derived senses. But they are not exactly identical, since the phrase patterns appear different. Section 5.3.2 has earlier shown that the completion sense of *over* is mostly used adverbially, though this does not occur with the LM, as in [t]he political damage may be limited if the fighting is over relatively quickly <W2E-006 #084>. In contrast, the LM of the completion sense explicitly follows *through* with the verb BE co-occurring and it can therefore be suggested that the clause pattern follows that shown in Figure 7.13 below. The completion sense of *through* seems likely to derive from the on-the-other-side-of sense and was classified thus in a few of the instances.

- (29) 'He's halfway through a bottle of the best cognac the villa has – courtesy of Gina and Tomaso Lucca, who are being so kind to him.' <W2F-016 #094>

⁴ Strictly speaking, the HA combination example (30) should be introduced in a later section, not in the present section, of the CC and HC combinations. However, it is mentioned here in order to examine the instances of 'halfway through'.

- (30) Murray phoned when I was half way [sic.] through the quote. <W1B-006 #044>

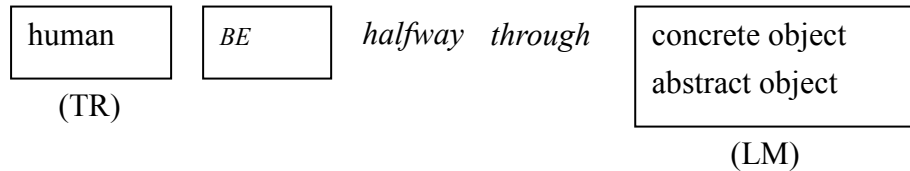

Figure 7.13 Clause pattern of the on-the-other-side-of, completion sense of *through*

Spread covering

The covering sense has been discussed with regard to *over* in Chapter 5 and we have identified that the covering falls into four types: distributive location, multiplex path, lacunal covering and concealing covering (Dewell, 1994, 2007; Jackendoff, 1990; Lakoff, 1987). The density of covering varies in geometric transition from points and linear to planar (see Figure 5.10, section 5.3.2, page 135). As for ‘distributive location’, scattered points can be construed as covering, as in ... *many sanctuaries that at that point had existed all over the country* ... <S1B-001 #004>. ‘Multiplex path’ signifies that the TR’s pathway throughout the LM can be perceived as a planar cover, as in *[h]e’s going all round Italy Austria Switzerland all over the place inter rail, so*. <S1A-081 #274>. ‘Lacunal covering’ and ‘concealing covering’ differ in density. The former represents multi-directional covering, as honey spreads over a pancake (Dewell, 1994), but the TR does not conceal the LM, as in *[m]ulching materials such as straw or hay, or sheets of black polythene, can also be spread over the soil surface*... <W2B-027 #117>. However, in the latter the TR hides the LM so that it cannot be seen, as in ... *it’s impossible for the Tories to paper over the cracks*... <S2B-006 #041>. So, turning to the covering sense of *through*, is it similar to the senses of *over*?

Covering senses	Trajector		verb		<i>through</i>	Landmark	ICE sentence code
distributive location	they	[tumours] either	spread	from the primary site to ...	through the blood system	S 2A	035 057
	sockets		spread	the pressure of the levelling bolts	through the slate	W 2A	040 088
multiplex path	sewers		run		through the streets	S 2B	022 111
	the root	to	wriggle		through the soil	W 2A	025 026
lacunal covering	The sound	of ...many choirs	echoes		through arches	S 2B	027 097
	water	to	penetrate		through the sediment	W 2A	022 041
	blood	wouldn't	seep		through Lewis's trousers	W 2F	015 081
concealing covering							

Table 7.9 Spread covering senses of *through* phrases in the CC combination

Table 7.9 shows that the concealing covering sense was not found in the instances of *through*, although the other senses were observed. Similarly, the instances of the other HCA combinations, one instance each in the HH, the AH and the CA, two in the AC and five in the AA, were examined, revealing no instances of concealing covering either (Table 7.10 below). This seems to suggest that the covering sense of *through*, unlike that of *over*, does not convey concealing, since the path movement of *over* runs above the LM which can be concealed by the TR, while that of *through* runs through the inside of the LM and the trajectory is unlikely to conceal the LM.

Covering senses	Trajector		verb	<i>through</i>	Landmark	HCA	ICE sentence code
distributive location	institutions	...widely	spread	through	society	HH S 2A	038 071
	it	[writing]	went	through	everything	CA S 1A	094 318
	surges	of violence, which	swept	through	18 jails	AC W 2C	007 070
multiplex path	these two lines	of poetry	going	through	my mind	AA S 1A	032 169
	that		runs	through	all of the faiths	AA S 1B	028 011
	an old saying	... that continually	went	through	my mind	AA W 2B	012 118
lacunal covering	it	[unbelief]	spread	through	society	AH S 2B	029 002
	policy	is	showing	through	certain clauses	AA W 1B	029 064
concealing covering							

Table 7.10 Spread covering senses of *through* in the combinations except for the CC

The analysis of *over* in Chapter 6 has shown that particular verbs tend to co-occur with particular types of TR movement: for instance, those in a multiplex path, such as *DRIFT*, represent the tight track of the TR's movement within the LM; those in lacunal covering, such as *SPREAD*, illustrate a sprawling movement of the TR. Do the verbs with *through* show a

similar tendency? Although only a few instances were found, *SPREAD* as in (31) occurred frequently in the distributional location sense (three instances in Tables 7.9 and 7.10). This contrasts with the finding in Chapter 5 that *SPREAD over* was found only in the lacunal covering sense. It can consequently be inferred that ‘*SPREAD over*’ and ‘*SPREAD through*’ may denote different covering senses, although the same verb occurs in both phrases. This raises the question of the extent to which the verb, the preposition or the combination of TR and LM determines the meaning of the phrase. As regards multiplex paths, similar verbs to those with *over*, which represent movement in all directions, were found in the instances of *through*, such as *RUN* and *WRIGGLE*, as in (32) and so were the verbs in the other combination, such as *GO* and *RUN*, as shown in Table 7.10 above.

- (31) They either spread locally from the primary site to within the lung or they [tumours] spread, through the blood system ... <S2A-035 #057>
- (32) ...such behaviour helps the root to wriggle through the soil while maintaining nutritional contact with soil particles. <W2A-025 #026>

By means of

The ‘by means of’ sense occurs with *through*, but not with *over*. A comprehensive study of prepositions by Dirven (1993) has shown that such prepositions as *at*, *on*, *in*, *by*, *with* and *through* have the sense of means and manner, whereas *over*, whose mental representation of the central sense is based on path movement, does not (see Table 6.5 in Chapter 6, page 196). This may be because the conduit metaphor of *through* is associated with intermediation between two entities, in that the TR is supposed by definition to go through the inside of the LM in order to reach the end-point. The concept of contact between the TR and the LM metaphorically gives rise to the involvement of the two entities in order to achieve something. In contrast, the TR of *over* goes above the LM and does not necessarily make contact with the

LM, resulting in the absence of the ‘by means of’ sense in the derived senses. The difference between the mental representations is likely to be reflected in the existence of the ‘by means of’ sense of *through*.

The verbs and TRs in the CC and HC combinations clearly show the distinctive features of this sense of *through*. As shown in Table 7.11 below, the verbs of the CC combination convey the idea of ‘power which makes something move’, such as *DRIVE*, *OPERATE* and *POWER*. In accordance with the verbs, the TRs and the LMs represent the relationships between something supplying the power and the means of providing the power, such as *engine* and *gearbox*; and *winch* and *block*, as in (33) and (34) respectively. In addition, in the verbs of the HC combination *BREATHE* occurred frequently; however, all the instances come from a single text in which the symptom of a blocked nose was repeatedly mentioned. Even so, it is true that personal pronouns occur frequently in the HC combination. Pronouns appear frequently in the conversational registers: 90 % of the HC combinations in the ‘by means of’ sense were found in the spoken sub-corpora (the instances marked ‘S’ in Table 7.12). At the same time, a number of instances in the CC combination are found in the written sub-corpora. This may imply that, according to the concordance lines, the instances are likely to come from instructions for, or descriptions of, machinery. Hence, the classification of the HCA combination may possibly shed light on differences between spoken and written registers.

- (33) It [the engine] drives the front wheels through an automatic gearbox.
<S2A-055 #031>
- (34) The winch, which raised and lowered the drill bit with a single pull capacity of 36t, operated through a crown block... <W2A-031 #091>

ICE sentence code	Trajector	verb	<i>through</i>	Landmark
S 2A 055 031	it	[engine] drives	the front wheels through	an automatic gearbox
W 2A 033 012	the milk	to extract	through	which [hose]
W 2A 031 091	The winch	operated	through	a crown block
S 1A 088 051	it	[film] post	through	developer fixer
W 2A 031 089	which	[motors] powered	through	3:1 reduction gears
W 2D 012 003	most water	is provided	through	pipes
W 2B 027 070	All nutrients	on the farm are recycled	through	famyard manure

Table 7.11 TR and LM of the ‘by means of’ sense in CC combination

ICE sentence code	TR	verb	<i>through</i>	LM
S 1A 051 111	I	can't breathe	through my	nose
S 1A 051 115-2	I	couldn't breathe	through my	nose
S 1A 051 115-1		a lot to do with breathing	through my	nose
S 1A 051 116	I	was breathing	through my	mouth
W 2A 026 150	the patient's	ability to interpret	<i>sensations</i> through	fewer innervated receptors
S 2B 050 050	us	lead	through the back	door
S 1B 016 121	you	sense	through your	eyes
S 1B 079 104	you	smoke	through the	nose
S 1B 023 116	we	went	through the music	cues

Table 7.12 TR and LM of the ‘by means of’ sense in HC combination

7.3.2 CH and HH combinations

As noted in the above analyses of *over* and *into*, few instances of the CH combination were found – four of them with *over*, no instance with *into* and only three with *through*. This may be partly because the configuration in which a concrete TR passes, penetrates and traverses a human LM rarely occurs and therefore it is hardly ever a bodily experience. As regards *through*, there were two instances of the traversal sense and one of the ‘make someone do’ sense, which will be examined in detail later in the account of the HH combination. It appears that the configuration of these traversal instances is metaphorical, rather than physical. For instance, example (35) illustrates that the TR, *the pass*, seems unlikely to traverse the body of the LM, *Jimmy*; rather, the LM is construed because of its function as an entity which obstructs the TR’s path movement and success is achieved only if the TR gets through the LM. Furthermore, similar to the covering sense, a mass of members was construed as an LM, as in (36): that is, the individual defenders were perceived as the components of *his defences*.

(35) Before the kick will be taken attention is going to be paid, to Kolianov... but

still managed to get the pass through Jimmy to Mostovoi... <S2A-014 #275>

(36) The ball went straight through his defences, uh... <S1A-095 #065>

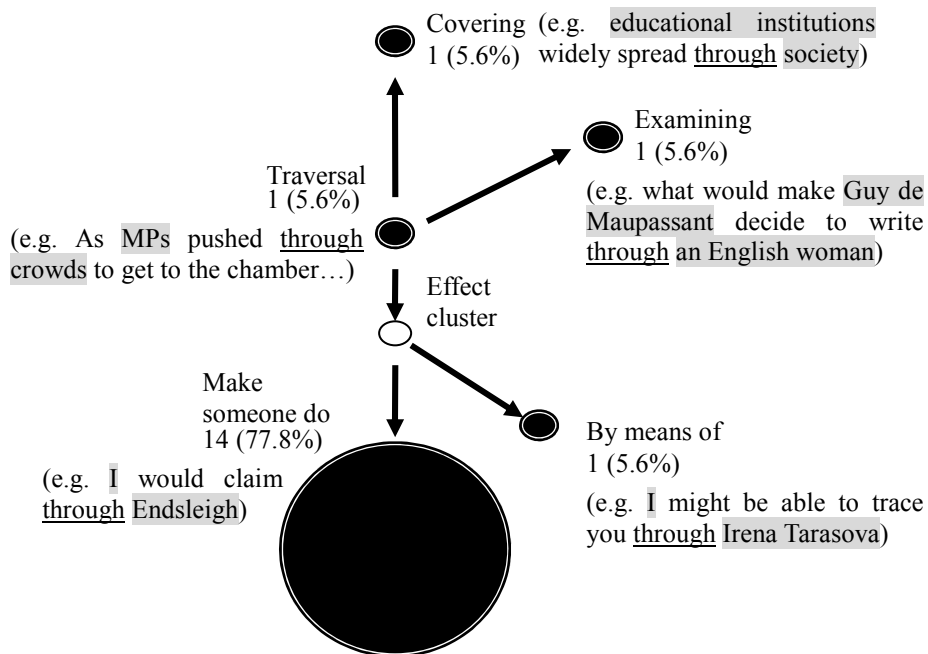

Figure 7.14 Semantic network of the HH combination

The ‘make someone do’ sense overwhelmingly occupies the instances of the HH combination (77.8%, 14 out of 18 in Figure 7.14). It seems to originate from the conduit metaphor related to the central sense of *through*. In other words, a motive of the TR is carried through the mediator LM in order to achieve an aim. Example (37) clearly indicates that the TR, *I*, wants to obtain compensation by requesting an insurance company, *Endsleigh*, to provide it. Hence, the verbs of the sense tend to be those which make someone do something, such as *CLAIM*, *NEGOTIATE*, *PURSUE* and *WORK*, as shown in Table 7.13. In addition, the distinctive LMs represent people, groups and organisations which function as mediators in order to take up the offer from the TR, namely *agency*, *GP*, *the NHS*, *the EC* and *the United Nations*. Finally, the clause pattern of the sense also seems to relate to the meaning. For

instance, the frequent occurrences of personal pronoun and pro-verb are likely to imply that this sense is often used in the spoken register, and this hypothesis is validated by the high frequency of the spoken instances shown in Table 7.13 (92.9%, 13 out of 14 instances). Furthermore, the patterns in the predicates seem to indicate that the sense tends to occur with reference to a future action, as in (38), e.g., *BE going to*, progressive, *try to* and *want to*. Consequently, the clause pattern of the ‘make someone do’ sense in the HH combination can be illustrated as Figure 7.15.

- (37) So **I** would actually claim through **Endsleigh**. <S1B-074 #030>
- (38) Aren't **you** going to do it through **an agency** then? <S1A-021 #206>

ICE sentence code	TR	verb	through	LM
S 1B 074 030	I would actually	claim	through	Endsleigh
S 1B 026 236	Charles Dickens is	communicating	through	you
W 1B 019 021	we	communicating	through	who
S 1A 015 049	we 've been meaning to	do it	through this	friend
S 1A 021 206	you going to	do it	through an	agency
S 1A 062 117	you need to try to	do that	through your	GP
S 1A 021 211	we 've always	done it	through	[agency]
S 1B 039 093	your	going	through	the NHS
S 2B 031 056	he	maintains a common standard	through the	offices
S 1B 055 033	those who	negotiating on behalf of...	through	the EC
S 2B 042 059	he	pursue his literary career	through the	medium
S 1B 033 075	we have an ability to	respond to the national...	through the	medium
S 2A 036 086	God	spoke	through his	messenger
S 1B 035 100	he wants to	work	through the	United Nations

Table 7.13 TR, LM and verbs of the ‘make someone do’ sense in HH combination

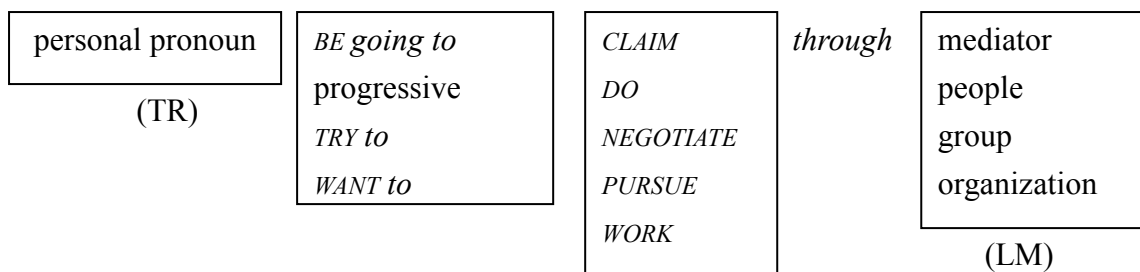

Figure 7.15 Clause pattern of the ‘make someone do’ sense in HH combination

7.3.3 HA combination

The HA combinations of *through*, as well as *over* and *into*, appeared to have the most varied senses in their semantic networks: 10 senses of *through* (83.3%, out of 12 senses), 12 of *over* (80.0%, out of 15 senses), and 11 of *into* (78.6%. out of 14 senses). A great many of the derived senses contribute to the making of an elaborate semantic network, as shown in Figure 7.16. Such diverse senses in the HA combination imply that to a large extent the human TR relates metaphorically to an abstract object LM and the spatial configuration of the prepositions is mapped onto a metaphorical configuration through human activities. We explore in this section the way in which the metaphorical extensions of *through* are used.

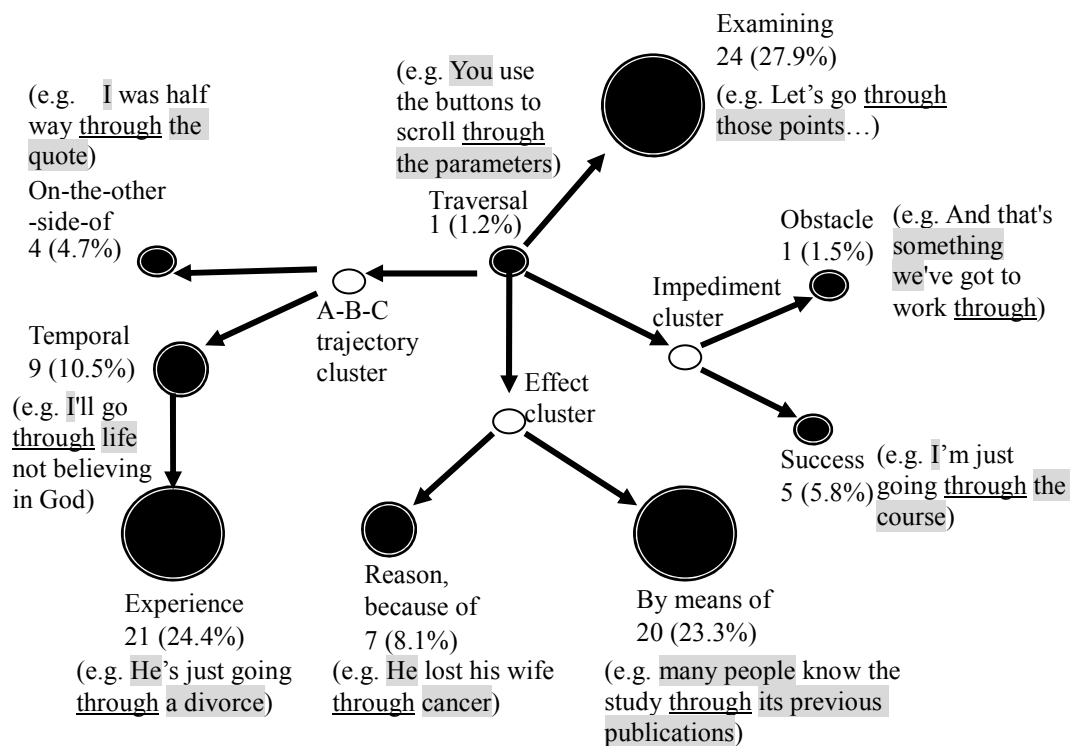

Figure 7.16 Semantic network of the HA combination

Temporal

The temporal sense was found in the HA (9), CA (2) and AA (8) combinations – the numbers in parentheses indicate the number of instances of the temporal sense. As shown below in

Table 7.14, amongst the instances of the combinations, the LMs which are temporal words seem similar, for example, *day*, *time* and *period*. However, the co-occurring verbs show some distinctive features: while *GO* occurs both with *through* and *into*, *GET* distinctively conveys the penetration of *into*, as in (39). Such verbs with *over* as *DO*, *HAVE* and *TAKE* imply that actions during a certain period are highlighted, as in (40); this is unlike *through*, as in (41), where the passing of time is focused on, rather than what the TR does.

preposition		verb	LM
<i>through</i>	HA	<i>go, run</i>	<i>months, year, life, morning, period, day</i>
	CA		<i>afternoon, journey</i>
	AA	<i>pass, run</i>	<i>1991, time, childhood, recession, December, Saturday</i>
<i>over</i>		<i>do, have, take</i>	<i>decades, hours, period, day, time, Christmas, lunch</i>
<i>into</i>		<i>go, get</i>	<i>age, century, the Roman period, time, war</i>

Table 7.14 Verbs and LMs with *through*, *over* and *into* in the temporal sense

- (39) I've talked of the tendency of some people, dissatisfied with retirement, and they may have been unjustly treated in being put there, wishing to get back into the second age. <S2A-038 #066>
- (40) With all the bits of work you've done over the years, your CV must be pretty full? <W1B-001 #180>
- (41) ... you know apart from jobs that anybody is going to manage to get through a year in private accommodation... <S1A-078 #144>

Experience

The experience sense was found only in the instances of the HA combination. When the LM was a particular event which did not refer specifically to time, with the TR experiencing it, the instance was classified as an example of the experience sense. Take example (42) below, for instance: the TR, *he*, experiences an event of the LM, *divorce*, which is probably experienced more as a state than an event, and therefore the instance fell into the experience category, not

into the temporal.

(42) Uh, now **he's** just going through a **divorce** again. <S1A-076 #042>

Table 7.15 below illustrates the TRs, LMs and clause pattern in the experience sense. As discussed above, the LM is not so likely to refer to time as to experiences and events. Such events as *divorce* and *troubles* were found in the instances, while terms of transition, such as *stage(s)*, *phase* and *trials*, also occurred as the LM, for instance in (43). Like the other TR human combinations, the HC and HH, personal pronouns frequently occurred as the TR in the instances from the spoken sub-corpora. Most importantly, the pattern of *GO through* was overwhelmingly found to account for more than 90% of the instances (19 out of 21). It is likely that physical path movement relating to 'going through' the LM is mapped onto the metaphorical sense of experiencing it.

ICE sentence code	TR	verb	through	LM
S 1A 060 005	you to	go	through	it
S 1B 003 046	children seem to	go	through	the same stage
S 1B 050 069	who [actors] would	go	through	a number of productions
S 2A 033 083	I 'd	go	through	the different stages
S 2A 053 018	we	go	through	some very simple biochemistry
S 2A 054 002	we will now	go	through	the basic controls
S 2A 056 098	you will	go	through	a series of basic manoeuvres
W 1B 008 114	I have had to	go	through	that [strain]
S 2A 038 042	everyone	goes	through	that something
S 1A 072 111	I was	going	through	adolescence
S 1A 076 042	he 's just	going	through	a divorce
S 1A 076 050	he 's	going	through	the divorce
S 2A 037 055	Texas is	going	through	very serious troubles
S 1B 030 138	people ...who have	gone	through	investigation
S 1B 037 019	it [NL Fund] has	gone	through	a phase
W 2A 012 004	people have	gone	through	the movements
S 2A 029 002	I 'd	run	through	one of the trials
W 2F 020 215	I want to	thread	through	a half-hour programme
S 1A 052 215	you	went	through	what
S 1B 065 032	you	went	through	what
W 1A 001 007	Britain	went	through	either cataclysm

Table 7.15 TR, LM and verbs of the experience sense in HA combination

- (43) And I basically made a list of the different stages I'd go through if I was examining the system ... <S2A-033 #083>

Examining

The examining sense was also found in the derived senses of *over* and the central sense closely related to path movement may be mapped onto the skimming eye movements of examining, as in (44). The central sense of *through* is also based on path movement and one of the derived senses appears to denote examining, whereby the TR thoroughly checks the content of the LM, *those points*, as in (45). Despite being not coined to do so, the concerning/about sense of *into* is likely to denote TR's examining of the LM, as in (46).

- (44) I'd already given some thought to my approach and went over it again in my head now - although much would depend on circumstances. <W2F-004 #037>
- (45) But basically let's go through those points where the regularity can be violated... <S2A-025 #012>
- (46) Yeah, I was looking into genetic and environmental aspects and the major arguments for the genetic... <S1B-003 #174>

All of the examining senses above were found in the HA combination. Thus, we next look at which HCA combinations the examining senses were found in. Table 7.16 indicates that the HC and HA combinations frequently occurred in the examining sense. This seems to suggest that, as might be expected, the examining sense is mainly used in human activities where the human TR investigates a concrete object or abstract object LM.

	sense	HH	HC	HA	CH	CC	CA	AH	AC	AA	total	
											sum	%
<i>over</i>	examining		5	6		1					12	3.0
<i>into</i>	concerning/about		5	46			1			9	61	9.4
<i>through</i>	examining	1	15	24							40	13.6

Table 7.16 Distribution of the HCA combinations in the examining sense⁵

With regard to the co-occurring verb, *GO* was overwhelmingly found in this sense, for instance, in (45) above, accounting for more than half of the instances (51.3%, 20 out of 39, Table 7.18). The table below shows how frequently the phrase pattern of *GO* + *over/into/through* occurred in the examining sense. Out of the 39 instances of this sense with *through*, *GO through* occurred in 5 instances in the HC and 15 instances in the HA. As well as *GO over*, *GO through* appears to be used frequently in the examining sense. Table 7.18 also indicates that quite a few instances of *RUN through* were found in this sense. Although *GO* is employed with *over* and *into* to convey the sense, *RUN over* and *RUN into* do not mean experiencing. Hence, it can be implied that verbs to a certain extent contribute to the interpretation of what the phrases might mean.

		HC	HA	total	
				sum	%
go	<i>over</i>	2	4	6/6	100
	<i>into</i>	0	17	17/46	37.0
	<i>through</i>	5	15	20/39	51.3

Table 7.17 *Go* + *over/into/through* in the examining sense

⁵ The percentages were computed by dividing the instances of the examining sense by the number of instances of each preposition. For instance, there were 40 instances of the examining sense of *through*; this number was then divided by 295, the total number of instances of *through*.

ICE	sentence	code	TR	verb	through	LM
W	1B	002	074	I	was reduced to	flicking through channels
S	1A	075	132	we	to	get through a lot [things]
S	1A	045	226	we	'll	go through it [work]
S	1A	072	192	I	won't	go through the whole story
S	1A	082	151	I	can't	go through that sector
S	1A	090	050	he		go through that [translation]
S	1B	004	281	we		go through them [factors]
S	2A	025	012	we		go through those points
W	2F	008	163	you		go through my things
S	1B	063	081	you		going through each and evry part of interview
S	1B	079	190	I	'm	going through this [point]
S	1B	080	031	you		going through it [number]
S	2B	010	067	they	[Russians] to be	going through the motions
S	2A	023	065	we	have	gone through a very detailed process
S	2A	028	134	you	've	gone through an exhaustive search
S	2A	030	134	I	've	gone through them [features]
S	2A	034	001	I	'll	have through words
W	2D	018	048	engineer		looking through an inspection opening
W	2F	018	083	Cosmo		ran through a few historical dates
S	1B	072	229	she	having	run through the agreement
S	2A	021	096	I	shall	run through them [features]
S	2A	062	020	I	shall	run through a chronology
W	2F	009	136	she		thinking through the book
S	1A	094	296	he		went through his [words]

Table 7.18 TR, LM and verb of the examining sense in HA combination

Table 7.18 also indicates the distinctive features of the LM, namely, that pronouns, such as *it*, *that*, *them* and *this*, as in (47), and plural nouns, such as *channels*, *points*, *things*, *motions*, *words* and *dates*, as in (48), frequently occurred. The high frequency of pronouns was also observed in the examining sense of *over*, as in (49).

- (47) What are some of the factors which affect the blood pressure level in a patient... Let's go through **them [factors]** fairly systematically. <S1B-004 #281>
- (48) And **I** know you go through **my things**. <W2F-008 #163>
- (49) Now Tony **we**'ll just go over **the basic procedures** to start your bike before you sit on it. <S2A-054 #053>

Obstacle and success

The obstacle sense and the success sense belong to the impediment cluster, since the LM

functions as a metaphorical barrier, such as a difficulty or problem, which the TR is intended to overcome. If the attempt is successful, the sense is interpreted as the success sense as in (50), while if it fails or seems difficult to achieve, it is the obstacle sense that is conveyed, as in (51). This seems to suggest that the functions and nature of the LM relate to the interpretation of the senses.

(50) but like I'm just going through the course. <S1A-034 #015>

(51) Pro-life groups have been angered this week by attempts to push through the introduction of a new abortion pill. <S2B-023 #047>

Although the 'by means of' sense and the 'reason/because of' sense were found in the HA combination, they will be examined in a later section in order to compare them with those in the AA combination.

7.3.4 AH, CA and AC combinations

The AH (5.8%, 17 out of the 295 instances), CA (2.0%, 6 instances) and AC (2.0%, 6 instances) combinations of *through* appeared much less frequently than the 'parallel' combinations, such as the CC (18.6%) and AA (11.2%). The combinations containing an abstract object TR are likely to occur less frequently, except for the AA combination. The AH combinations of *over* and *into* examined in the previous chapters appeared rarely – one instance of the former (0.2%) and eight of the latter (2.0%). But the combination of *through* accounted for 17 instances (5.7%), which is likely to be a result of the frequent occurrences of the 'make someone do' sense (11 instances), as shown in Figure 7.17 below.

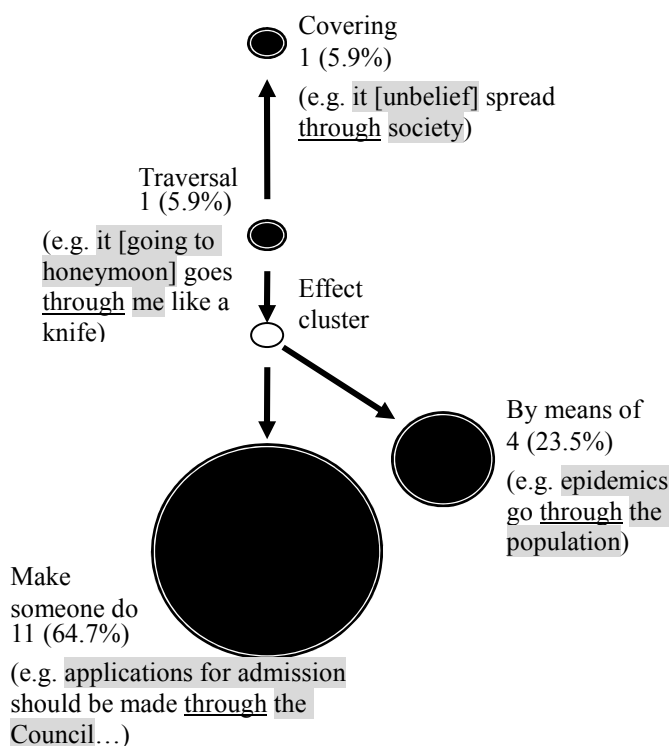

Figure 7.17 Semantic network of AH combination

ICE code	TR	verb	through	LM
W 2F 003 134	it	[going on honeymoon] goes	through	me
S 1A 001 038	that	[opportunity] has arisen	through	the group
S 1B 061 041	arrangement	arranged	through	his solicitor
W 1B 027 116	which	[deposit] has since been cleared	through	my bank
S 2B 021 113	his budget	goes	through	the Buddestag
W 2B 016 006	the Iron & Steel Nationalization Bill	was being guided	through	parliament
W 2D 007 023	All applications for admission ...	should be made	through	the Universities Central Council
S 1B 053 110	they	[subjects] are all negotiated	through	the Community
S 2B 007 040	the new Broadcasting Act	piloted	through	Parliament
W 2A 013 040	services	whether provided	through	the NHS
S 2B 039 040	policy	changes to seek	through	the members of parliament
S 1B 026 247	garbled stuff	to send	through	mediums

Table 7.19 TR, LM and verb of the make someone do sense in AH combination

Table 7.19 shows that the LMs are similar to the LMs with this sense in the HH combination (see Table 7.13 in 7.3.2 above): mediators were frequently found, such as *solicitor*, and so were groups, such as *Council*, *the Community*, *Parliament* and *the NHS*, which help the TRs' offers to take something up. Given that *NEGOTIATE* occurred in both the HH and the AH, the co-occurring verbs in this sense were found to denote demands and

requests, such as *arrange*, *provide* and *seek*, as in (52). Furthermore, the phrase pattern containing the verbs illustrates a feature distinguishing the AH from the HH: it is the passive voice that represents demands and requests which are responded to with the help of the LM, as in (53). In conclusion, the instances of the AH differ from the HH in that in the former the TR is the thing requested, while in the latter the TR is those who request.

- (52) Services for these groups tended to be institution based, whether provided through the National Health Service (NHS) or local government,... <W2A-013 #040>
- (53) All applications for admission to full-time courses ... should be made through the Universities Central Council on Admissions. <W2D-007 #023>

The other senses in the AH, and those of the CA and AC, which appeared in the statistical test to be considerably underused (see Table 7.2), are not discussed, due to the low number of instances.

7.3.5 AA combination

The AA combination turned out to be significantly overused, according to the statistical test of residual analysis. The overuse is seemingly reflected in the variety of the derived senses in the combination. Unlike the distribution of *into* examined in the previous chapter, that of the central sense of *through*, traversal (10.5%), was relatively infrequent in the AA, while such peripheral senses as temporal (21.1%), by means of (23.7%) and reason/because of (44.7%) accounted for most of the instances of the combination. This finding may strengthen my hypothesis, based on bodily experiences, that the abstract combination of the TR and LM conveys the sense of metaphorical configurations.

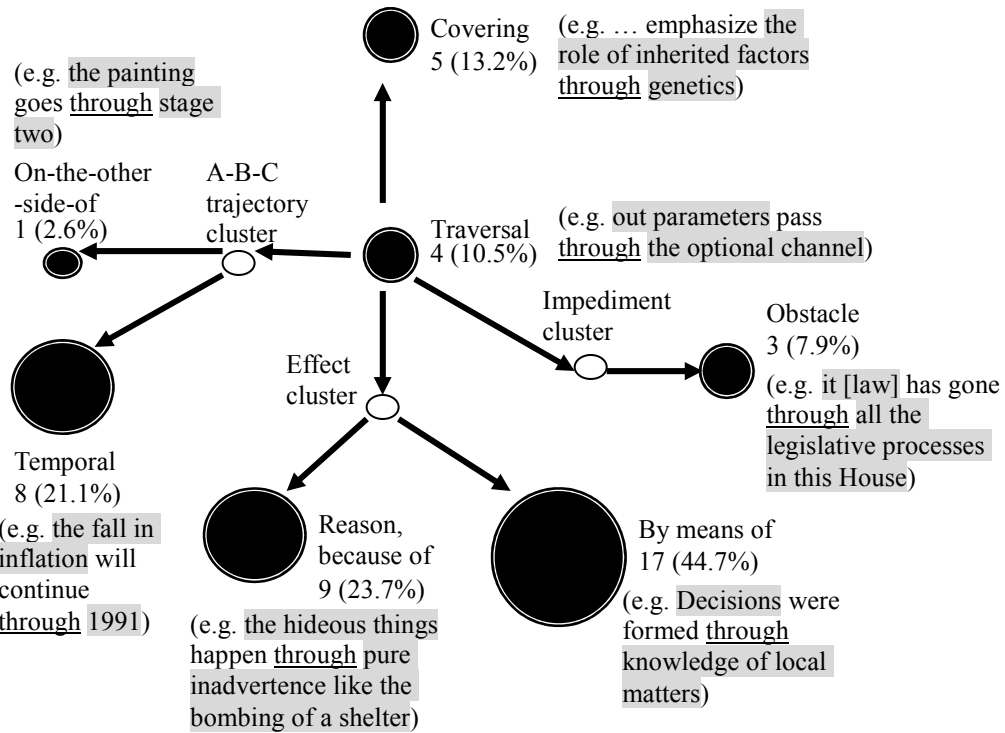

Figure 7.18 Semantic network of AA combination

Reason/because of

The ‘reason/because of’ sense was found in the HA, CA, AC and AA combinations. Of these, the HA (7 instances) and AA (9 instances) co-occurred somewhat frequently. The verbs with the combinations seem to suggest that unfavourable incidents are often involved, such as *COLLAPSE*, *HAPPEN*, *LOSE* and *SUFFER*, as shown in Table 7.20 below. In accordance with the verbs, the LMs, such as *agony*, *fatigue*, *inadvertence* and *boredom*, represent the reason for which the TR gets damaged or deteriorates, as in (54). The TR, irrespective of whether it is a human or abstract object, functions as victim of the consequence caused by the LM, as in (55). This can imply that the semantic prosody of the phrase tends to be negative, with indications coming from both the LM and the verb (Table 7.21 below).

TR		verb		through		LM	
insulation	has been	<i>broken</i>		<i>through</i>	the	<i>agony</i>	AA
a charge	of Coleridge	<i>collapsing</i>		<i>through</i>	a drug-induced	<i>fatigue</i>	AA
the hideous things		<i>happen</i>		<i>through</i>	pure	<i>inadvertence</i>	AA
the memories	are not	<i>lost</i>		<i>through</i>	insufficient	<i>encoding</i>	AA
this	[amnesia]	<i>occurs</i>		<i>through</i>	cued	<i>recall</i>	AA
this	[amnesia]	<i>occurs</i>		<i>through</i>	slowly	<i>building</i>	AA
they	[wars]	<i>sap</i>	morale	<i>through</i>		<i>boredom</i>	AA
translation	of Australian profits.	<i>suffered</i>		<i>through</i>		<i>currency swings</i>	AA
I	in order to	<i>carry</i>		<i>through</i>	a deception	<i>programme</i>	HA
them	[Cavel and Cornwall	<i>dying</i>		<i>through</i>		<i>gallantry</i>	HA
Stelman		<i>explained</i>	the disruption of voice	<i>through</i>	an	<i>increase</i>	HA
Partridge	is	<i>forced</i>		<i>through</i>	Allworthy's	<i>misjudgement</i>	HA
wife		<i>lost</i>		<i>through</i>		<i>cancer</i>	HA
health authorities	to	<i>raise</i>	a further 290 million	<i>through</i>		<i>land sales</i>	HA
economists	have even	<i>talked</i>	of the war paying	<i>through</i>	lower	<i>inflation</i>	HA

Table 7.20 TR, LM and verb of the reason/because of sense in the AA and HA combinations

- (54) And it is sometimes coupled to a charge of Coleridge collapsing through a drug-induced fatigue into a snug intellectual cocoon. <W2A-003 #013>
- (55) He lost his wife through cancer and his daughter is also 4. <W1B-003 #188>

PROSODY	negative consequence			
PREFERENCE	victim			reason
COLLIGATION	<u>noun</u>	<u>verb</u>	<u>preposition</u>	<u>noun</u>
COLLOCATION	<i>charge</i> <i>memories</i> <i>translation</i> <i>wife</i>	<i>COLLAPSE,</i> <i>HAPPEN,</i> <i>LOSE</i> <i>SUFFER</i>	<i>through</i>	<i>agony</i> <i>fatigue,</i> <i>inadvertence</i> <i>boredom</i>

Table 7.21 Units of meaning of the 'reason/because of' sense of *through*

7.4 Implications of the HCA combination analysis

The previous section introduced the central and derived senses of *through*, taking the hypothesis that the combinations containing humans (H) and concrete objects (C), in particular the CC and the HC, closely relate to the central sense of prepositions, since the configuration can be bodily experienced. Conversely, those containing abstract objects (A), such as the HA and the AA, are associated with the peripheral senses, because they are highly likely to derive from metaphorically extending the spatial configuration of prepositions into

abstract concepts. Again, Table 7.22 below illustrates in the rows and columns the distribution of the senses of the HCA combinations, which extend from the central, physical ‘traversal’, to such peripheral senses as ‘by means of’ and ‘reason/because of’. This results in a weakly positive yet statistically significant correlation ($r = 0.441$, $p < 0.001$) between the distribution of the HCA combinations and the central sense to the peripheral senses. As a result, the semantic network of *through* can be established as shown in Figure 7.19 below. The relative incidence of the senses is also indicated in Figure 7.20 below, namely that the central sense, traversal, occurred most frequently, while at the same time the peripheral senses, such as covering, examining, ‘by means of’, ‘make someone do’, ‘reason/because of’ and ‘temporal’, were found to occur relatively frequently. My hypothesis on the basis of entrenchment is that the recurrent exposure of particular senses may encourage us to associate the word with the experiences of such use. The correlation between the HCA combinations and the senses implies that both the central and peripheral senses of *through* may possibly be entrenched by their frequent usage. In other words, it is likely that a number of the senses, the central and some of the peripheral at the same time, may possibly contribute to establishing the mental representation and the concepts of the polysemous *through*.

senses	CC		HC		CH		HH		HA		AH		CA		AC		AA		sum		
	F	%	F	%	F	%	F	%	F	%	F	%	F	%	F	%	F	%	F	%	
T Traversal	34	(41)	35	(43)	2	(2)	1	(1)	1	(1)	1	(1)			4	(5)	4	(5)	82	25.9	
A-B-C trajectory cluster																					
PR Protusion	3	(100)																	3	0.9	
OS On-the-other-side-of			6	(55)					4	(36)							1	(9)	11	3.5	
TM Temporal									9	(47)			2	11			8	(42)	19	6.0	
EXP Experience									21	(100)									21	6.6	
CV Covering	7	(44)					1	(6)			1	(6)	1	6	2	(13)	4	(25)	16	5.1	
EX Examining			15	(38)			1	(3)	24	(60)									40	12.7	
Impediment cluster																					
OB Obstacle	3	(33)	1	(11)					2	(22)								3	(33)	9	2.8
SC Success									5	(83)			1	17					6	1.9	
Effect cluster																					
BM By means of	7	(11)	9	(15)			1	(2)	20	(33)	4	(7)	2	7			18	(30)	61	19.3	
MS Make someone do					1	(4)	14	(54)			11	(42)							26	8.2	
BO Reason, because of									7	(32)			3	14	4	(18)	8	(36)	22	7.0	
	54	(17)	66	(21)	3	(1)	18	(6)	93	(29)	17	(5)	9	(3)	10	(3)	46	(15)	316	100.0	

Table 7.22 Distribution of the HCA combinations and the senses of *through*

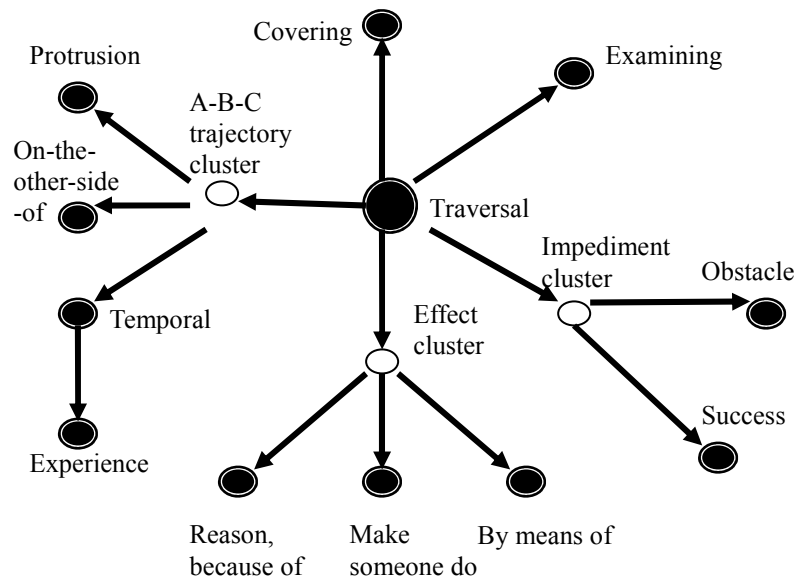

Figure 7.19 Semantic network of *through*

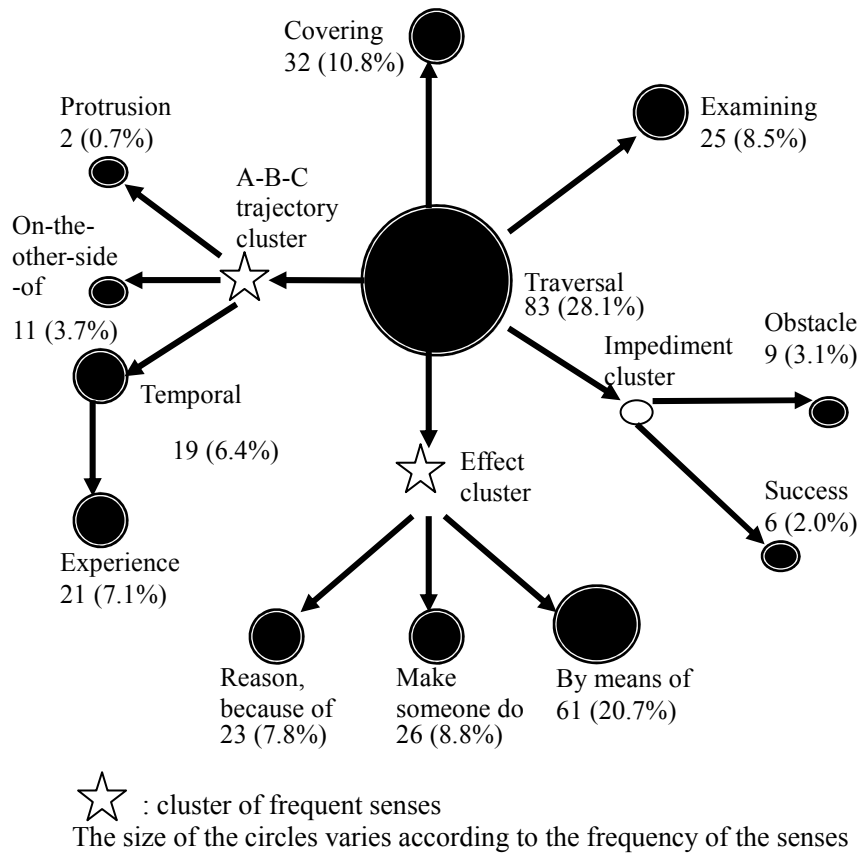

Figure 7.20 Frequency-based semantic network of *through*

It appears that the HCA combinations can contribute to the establishment of a semantic network, as they did in the account of *into* in the previous chapter. Figure 7.21 below illustrates the senses in which the CC, HC, HA and AA combinations occurred frequently. Similar to the semantic network of *into* (Figure 6.20 in section 6.4, page 226), the CC combination was frequently found in the central sense and the senses directly derived from it, such as ‘protrusion’ and ‘covering’, while the AA combination occurred in the ‘temporal’ sense, and in the senses belonging to the effect and impediment clusters. The CC combination, which can be bodily experienced, appears not to share the distribution of the senses of the AA combination, which, in contrast, is unlikely to be bodily experienced. Furthermore, the domains of the HC and the HA combinations illustrate that the different nature of the LM gives rise to different senses. For instance, the HC was frequently seen in

the ‘traversal and ’‘examining’ senses, while the HA occurred in the metaphorical senses, such as ‘obstacle’, ‘success’, ‘by means of’ and ‘reason/because of’.

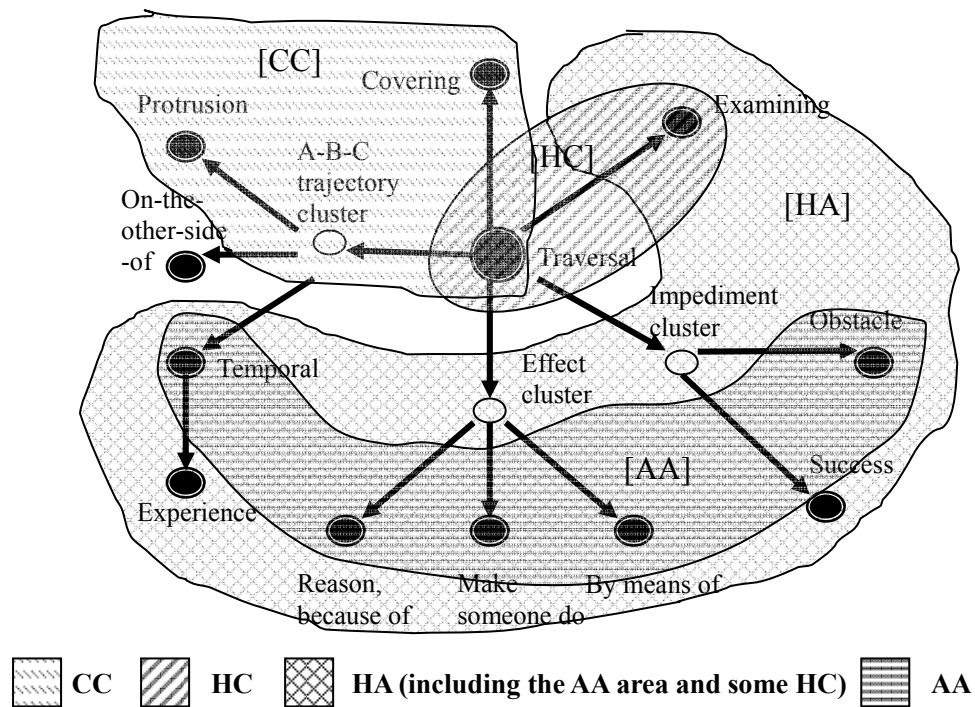

Figure 7.21 Domains of the HCA combinations

The distribution map of the combinations contributes to positioning the senses in the semantic network, and at the same time it indicates the radial extension of the senses. The semantic network is assumed to develop the extension of the senses from central to peripheral and the categorization of the members is structured in a radial formation (Brugman and Lakoff, 1988). Given the hypothesis of the network structure, Figures 7.22 and 7.23, shown below, seem to agree with it, in that the physical senses directly relevant to a spatial configuration extend towards the top left (Figure 7.22), while the figurative senses extend towards the bottom right (Figure 7.23).

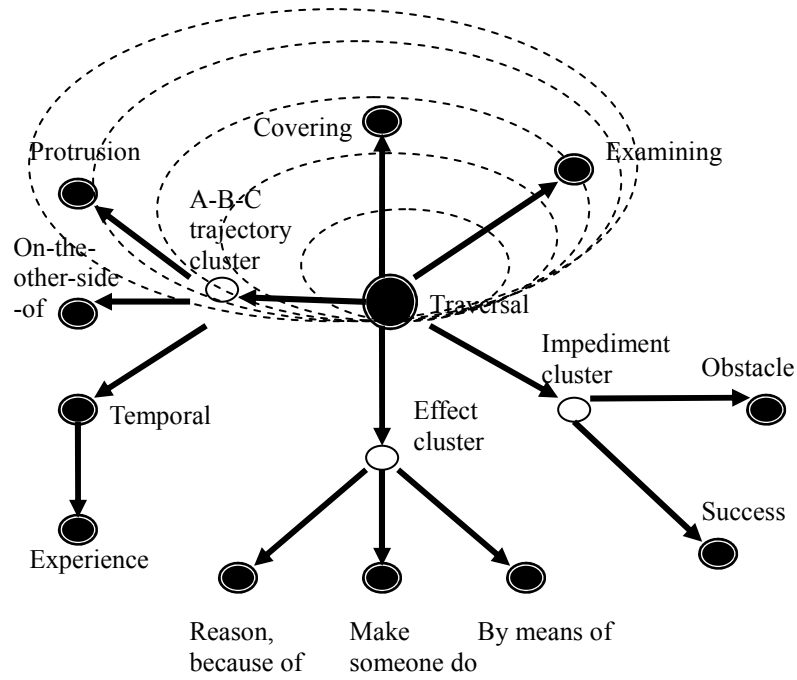

Figure 7.22 Radial category of the CC and HC combinations

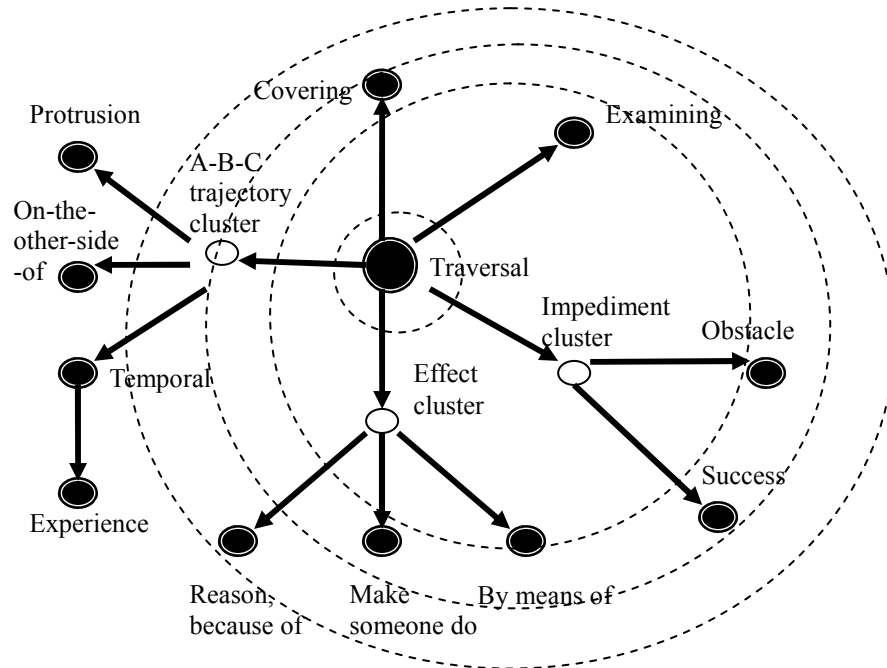

Figure 7.23 Radial category of the HA and AA combinations

7.5 Summary of the chapter

This chapter has examined the instances of *through* from the corpus data in order to explore the patterns of phrases containing the preposition. The results of the corpus analysis have suggested that *through* tends to be followed by a prepositional phrase with *to* and *into* much more frequently than *over* and *into*, e.g. *get through to/into....* This may be partly because the mental representation of *through* is unlikely to require the LM of a salient destination, as in *that jab thudding through his guard.*

Perceptual transformations of the LM into a bounded LM have often been observed in the data. In other words, the LM which does not retain space which the TR can traverse can serve as a bounded entity as long as it functions in the circumstances of a particular sense. For instance, as was seen in example (11), a point can serve as an LM with the TR passing beyond it. Such transformations are likely to contribute substantially to the interpretation of spatial and metaphorical configurations of prepositions.

The corpus data have also provided three statistical items of evidence in terms of the distribution of the HCA combinations. Firstly, the combinations of the TR and LM appear to be significantly polarised ($\chi^2 = 75.558$, d.f. = 4, $p < 0.001$) by dividing them into classes of human/animate (H), concrete object (C) or abstract object (A). Secondly, as regards the polarised distribution, the CC, HA and AA combinations were overused, while the CA and AA were underused. Finally, a weak yet statistically significant correlation was observed between the order of the combinations from concrete to abstract and between the central sense and the peripheral ones. For instance, the distribution pattern of the combinations has suggested that the CC and HC are associated with the central sense, ‘traversal’, while the HA and AA are associated with the peripheral senses. This result of the correlation between the HCA combinations and the senses appears to correspond to the findings on *into* in Chapter 6 (above).

8. DISCUSSION AND CONCLUSION

In this study, I have explored corpus data in order to describe the polysemous prepositions *over*, *into* and *through*. Using the set of categories comprising HCA (human, concrete object and abstract object) to classify the collocating nouns, I have empirically specified the collocations and patterns of these prepositions.

As explained in Chapter 1, research question 1 asks whether there exists a relationship between the sense of prepositions and their co-occurring nouns. The results of Chapter 5 have indicated that particular patterns of the TR and the LM were found with a particular sense of *over* and have demonstrated semantic association between the senses of *over* and their collocation. Moreover, Chapters 6 and 7 have demonstrated a statistical correlation between the senses of *into* and *through* and their TR and LM combinations which were categorized into HCA (Tables 6.13 and 7.22). Consequently, the relationship between preposition sense and its noun collocation has been observed.

Research question 2 asks to what extent the combination of the co-occurring nouns before and after the preposition can predict the senses of prepositions. The results found in Chapters 5 to 7 have demonstrated that certain types of TR and LM combination frequently occur with a particular sense of the designated preposition. The form, which is represented by the combination of the preceding noun and the following noun, can allow us to identify one particular meaning of the polysemous preposition. This finding leads to the hypothesis that we categorize the entities involved in the configuration represented by a preposition on the basis of our bodily experiences. In other words, a physical sense of a preposition is experienced in settings where concrete entities, represented as the trajector and the landmark, are involved. In contrast, when a relationship is posited between abstract entities, the preposition takes on a metaphorical

sense. I would argue that particular senses of the prepositions can be specified by identifying the HCA combinations in use in each case.

In addition to confirming the theory of form and meaning, the HCA combinations appear to be useful for establishing the semantic networks of *into* and *through* (Chapters 6 and 7). This is because the HCA combinations of prepositions (from the CC to the AA combination) form a continuum from the concrete sense to the abstract sense, and similar senses, which share the same combination, can be allocated to the same domain as one another. This network diagrammatically shows semantic extensions from the central sense to the derived ones. The process of the semantic extension seems to suggest a way in which the spatial sense is projected onto the metaphorical senses.

As regards research question 3, as to whether corpus analysis provides a different description from non-data based research, the analyses in Chapter 5 have provided detailed accounts of the linguistic environment of different senses of *over*, such as the co-occurring verb and the phrase pattern. Also, frequencies of different senses of *over*, *into* and *through* have demonstrated which sense is more typical than the others in everyday language use. HCA classifications have allowed me to provide detailed descriptions of the senses of *over*, *into* and *through*, their semantic network and metaphor, which I extensively discuss in the following sections.

8.1 HCA combinations and the senses of the preposition

Cognitive linguists, on the one hand, argue that we see the configuration of a preposition by means of the two entities involved: the trajector and the landmark. Corpus linguists, on the other hand, argue that a word has one or more collocations

which show distinctive patterns in different senses. I amalgamate the two propositions of the different linguistic approaches in order to describe the senses and linguistic environment of polysemous prepositions. Moreover, I adopt the classification of human (H), concrete object (C), and abstract object (A) in order to provide a categorization of the entities involved in the prepositions.

The HCA classification revealed a pattern in the nouns co-occurring with the seven prepositions in my pilot study (see Chapter 4). The pilot study indicated that *over*, *into* and *through* have the most similar distributions of HCA combinations out of the full set of prepositions. As a result of the pilot study, the combinations of nouns co-occurring with *over*, *into* and *through* were therefore investigated. Just as the distribution pattern of the preposition senses is unequal, so the frequency of the HCA combinations of the nouns turns out to be asymmetric. The uneven distribution of the combinations shows some similarity across the three prepositions. High standard residuals based on frequency were observed with the CC (concrete object trajector and concrete object landmark) and the AA (abstract object trajector and abstract object landmark) combinations. Statistical chi-square tests show that these noun combinations with *over*, *into* and *through* were found much more frequently than the other combinations. Conversely, the CA (concrete object trajector and abstract object landmark) and the AC (abstract object trajector and concrete object landmark) were less frequently seen with these prepositions, as illustrated in [Figure 8.1](#) below. The distribution patterning of the HCA combinations turns out to be similar in terms of the collocates associated with the prepositions.

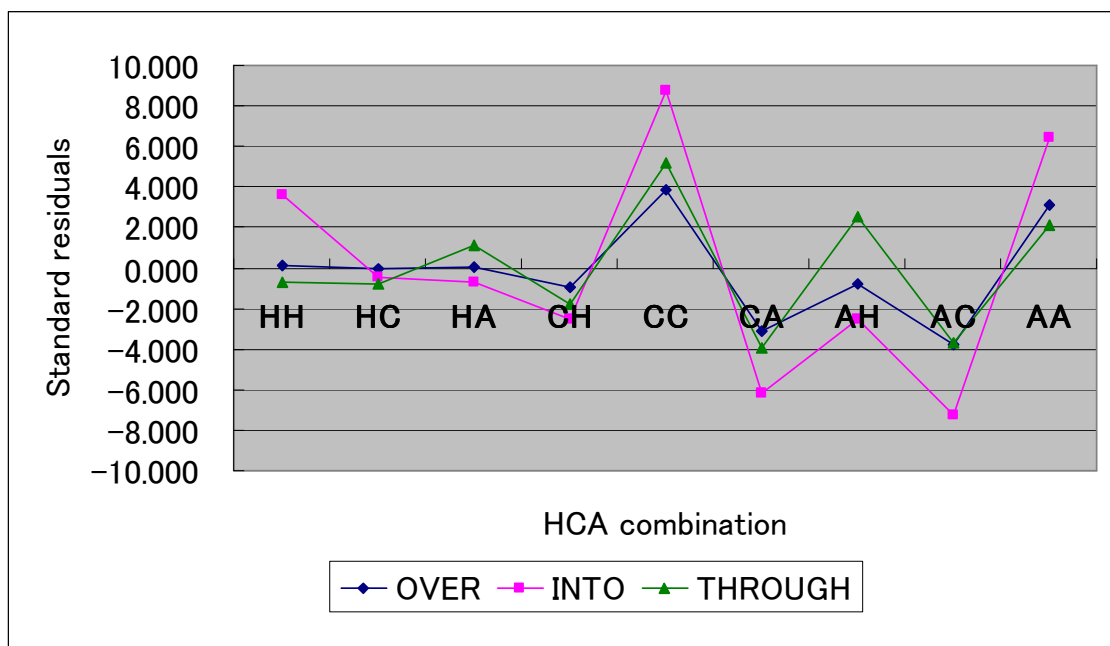

Figure 8.1 Standardised residuals of the HCA combinations of *over*, *into* and *through*

Figure 8.1 above shows the standardised residuals of the HCA combinations with the three prepositions. A residual indicates a statistical difference from the expected value induced from the observed frequency. In this case, the CC and the AA combinations of the three prepositions are found highly frequently. However, the CA and AC turn out to be statistically less frequent than the other combinations. This may imply that prepositions are used to describe the situation where a ‘parallel’ transition in movement from trajector to landmark, such as one concrete object to another concrete object; or one abstract to another abstract, is made. In other words, it is typical for us to see a transition between what applies to concrete objects and what applies to abstract objects. Also, it is unusual to construe a configuration composed of different types of entity, such as a configuration between a concrete object and an abstract object. It can therefore be concluded that the HCA analysis is a useful way of highlighting the linguistic behaviour of the nouns co-occurring with the prepositions. As the physical

movement sense is the most frequent of the prepositions' senses, the CC combination is more typical than any other combination of the co-occurring nouns. My corpus data show that the pattern of 'concrete object noun + verb + *over*, *into* and *through* denoting movement + concrete object noun' appears to be frequent (Table 5.18 in chapter 5, Table 6.18 in Chapter 6 and Table 7.22 in Chapter 7 respectively). This result suggests that the 'moving' senses of the prepositions correspond to the CC noun combinations. In other words, the senses are indicated by the collocation of the CC combinations. In turn, it can be argued that the sense of prepositions is likely to depend on the co-occurring nouns. My hypothesis that the combination of the co-occurring nouns can predict the sense of the preposition is supported in terms of the pattern of 'C + verb + *over/into/through* denoting movement + C'.

The high frequency of the prototypical sense of the prepositions can be explained by bodily experience. Spatial configurations represented by prepositions are often encountered from our earliest years when we play with toys and observe the way in which things move. Such experiences help to establish our conceptual templates, 'image schemas' (see section 2.3 above), such as container, path, blockage, which may closely relate to our conceptualisation of the prototype of prepositions. In this case of the sense of the prepositions and the HCA combinations, the high frequency of the prototypical sense of the prepositions and the CC combination is not a surprising result. We can physically experience seeing a concrete object moving to another object, while a metaphorical relationship cannot be physically experienced. The spatial configuration of the CC combinations is often seen and experienced in the real world. The highly frequent pattern of 'C + verb + *over/into/through* denoting movement + C' seems to support the hypothesis of the link between frequency and prototypicality. Although

frequency is not the only deciding factor of prototype, as explained in Chapter 2, my data show that the prototypical sense of the prepositions denoting movement, such as the on-the-other-side-of sense of *over*, the penetration sense of *into*, and the traversal sense of *through*, tends to be the most frequent of the polysemous senses. But one question remains unanswered. Why is the AA combination, which is unlikely to be prototypical in relation to embodiment, also frequent? As the temporal sense of *over* is very frequent (18.8%), particular metaphorical senses of the prepositions are likely to be frequent. Such metaphorical extensions of the senses are discussed later in Section 8.3.

Given that the movement sense of the prepositions corresponds to the occurrence of the CC combination, I would like to develop the hypothesis that the metaphorical senses also correspond to particular noun combinations. If an association between the metaphorical senses of the prepositions and the combinations containing an abstract object either as the trajector or as the landmark, or both them, is observed, it may suggest that a form (the HCA combinations) and meaning (the sense of the prepositions) relationship exists in metaphorical phrases. Firstly, I put the senses of the prepositions in order from prototypical to non-prototypical. The prototypical sense is a physical sense which can be experienced by the language user, whereas the non-prototypical sense is always to a greater or lesser degree metaphorical. In order to grade the degree of metaphor of the senses, I apply the ‘cluster’ of senses proposed by Tyler and Evans (2003a: 80). The cluster groups similar senses together and makes explicit a common concept of the senses in the same cluster. For example, the up cluster of *over* epitomises the senses of more (e.g., *If you are over age 60...* <W2D-004 #089>), control (e.g., *But when George Bush took over America...* <S2B-021 #019>) and preference (e.g., *...one might prefer the trilogy over earlier texts...* <W2A-004 #016>). I

followed Tyler and Evans and clustered the senses of *into* and *through* into batches of a common concept, and put them in the order of degree from the cluster of physical senses to that of metaphorical ones. The movement senses are at the top of the column of the senses of *over*, *into* and *through*. With regard to the clusters of *into*, the prototypical sense of movement is followed by the clusters of ‘collision’, ‘progression’, ‘retrogression’, ‘starting’ and ‘change of state’ in order, going from physical to metaphorical. Subsequently, the combinations of nouns occurring before and after the preposition were also put in order from the combinations of physical entities to those of metaphorical ones. As seen above, the CC combination is prototypical and the most frequent, and therefore it comes at the top of the list. Conversely, the AA combination is listed at the end because it is the least likely to be physically experienced. The senses of the preposition are listed in the left column and so are the combinations of the co-occurring nouns in the first row of the table. Then the occurrence of senses and combinations in my corpus data was plotted in Table 6.13 in Chapter 6 and Table 7.22 in Chapter 7.

senses	CC		HC		CH		HH		HA		AH		CA		AC		AA		sum	
	F	%	F	%	F	%	F	%	F	%	F	%	F	%	F	%	F	%	F	%
P Penetration	56	(21)	94	(36)			3	(1)	35	(13)	1	(0.4)	8	(3)	6	(2)	59	(23)	262	(40.4)
O Orientation	7	(32)	7	(32)					1	(5)			3	(14)			4	(18)	22	(3.4)
C Collision cluster			1	(100)															1	(0.2)
S Affecting surface, embedded	19	(95)	1	(5)															20	(3.1)
M Encounter							6	(100)											6	(0.9)
Progression cluster																				
IN Integration			3	(16)			7	(37)	9	(47)									19	(2.9)
TM Time									5	(63)							3	(38)	8	(1.2)
Retrogression cluster																				
W Withdrawal			2	(100)															2	(0.3)
IV Involvement									20	(100)									20	(3.1)
Starting cluster																				
AC Starting an action									29	(59)			4	(8)			16	(33)	49	(7.6)
ST Starting a state									26	(37)			10	(14)			35	(49)	71	(11.0)
CO Concerning, about			5	(8)					46	(75)			1	(2)			9	(15)	61	(9.4)
Change of state cluster																				
PR Change into parts or pieces	18	(33)					5	(9)	5	(9)			1	(2)			25	(46)	54	(8.3)
MP Metamorphosis	17	(32)					7	(13)	2	(4)			2	(4)			25	(47)	53	(8.2)
	117		113		0		28		178		1		29		6		176		648	(100.0)

Table 8.1 Distribution of the HCA combinations and the senses of *into*

As shown in [Table 8.1](#) ~~Table 8.1~~ above (a re-presentation of Table 6.13 in Chapter 6), the frequency of the senses and the combinations displays a general tendency towards a correlation between the senses of the preposition and the combinations. This co-occurrence is also observed between the senses of *through* and the HCA combinations of the co-occurring nouns. These results again seem likely to support my hypothesis that the collocations of a preposition can predict the sense of that preposition (see Chapter 1). The theory of phraseology in corpus linguistics holds that meaning does not emerge from a word but from the phrase composed of the word and the collocations. If the theory is applied to the results of this study, it is likely that it is not the preposition alone that denotes the sense which is considered to emerge from the preposition, but the phrase containing the preposition and the co-occurring nouns, which convey the physical and metaphorical senses of the preposition. To put it another way,

the senses of *into*, such as penetration, encountering, integration and the other senses, may be dissolved into the phrase containing the preposition with the collocations contributing to our determination of the sense.

As far as meaning is concerned, boundaries between words are unlikely to be important (cf. Taylor, 2003). Rather, the phrase composed of a word and its collocations determines the meaning (Huston and Francis, 2000). The senses which are considered to emerge from the preposition may depend on collocations such as the co-occurring nouns, verb and other elements of the phrase. As shown in Figure 8.2 below, I would argue that each element of the clause, for example, the nouns *the cat* and *the wall*, the verb *jumped* and the preposition *over*, functions to generate the meaning of the clause *The cat jumped over the wall*. Here the relationship between *the cat* and *the wall* is assumed to be close since they are named as the trajector (TR) and the landmark (LM). I apply the relationship of the two entities in a physical configuration to the semantic association of the nouns before and after the preposition. It appears that the TR and LM combinations, which are categorized into human (H), concrete object (C), and abstract object (A), can predict the sense of the preposition. Specifically, the combination of *the cat* and *the wall* can predict the on-the-other-side-of sense of *over*. This is because, through our experiences, we have knowledge that a cat is able to go to the other side of a wall. Moreover, the verb *jumped* adds more information to the movement to the-other-side. Articles and other grammatical markers, such as plural *-s*, can also contribute to the generation of meaning. *Eye* co-occurs with article *an* in the sense of surveillance as in *to keep an eye on something* (Danielsson, 2003), while visual organs tend to be expressed in the plural as in *dark brown eyes*. Although every word in the phrase and the clause can contribute to meaning, this study focuses on the combination of the preceding and

following nouns in order to discover the correlation with the sense of the preposition. In conclusion, the co-occurring nouns to a certain extent predict the sense of the preposition, although it may be the case that the sense is interpreted by the phrase.

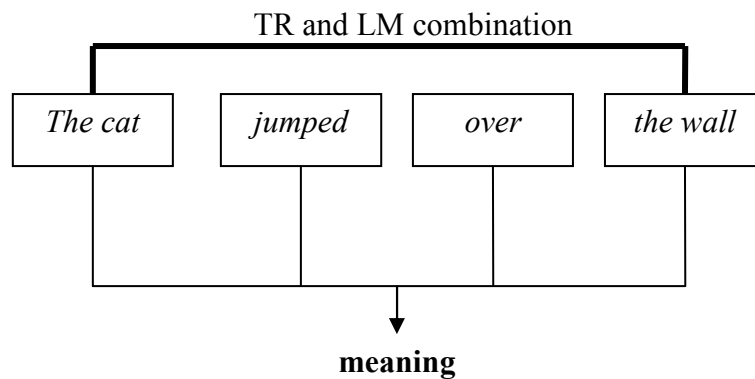

Figure 8.2 Generation of the meaning of *The cat jumped over the wall*

If it is the case that the phrase gives rise to the senses of the preposition, does the preposition alone, unlike the other words, not have an independent meaning? Is the preposition a dependent element of meaning, while the verb and noun contribute to the sense made of the phrase? While, in a dictionary of phrasal verbs, the verb is the entry word of the phrasal verb and the preposition (or particle) is its dependant, the particle index lists the senses of the phrasal verb as an indicator of the sense (Sinclair *et al.*, 2002). As discussed in the earlier chapter on *over* (see Chapter 5), the verb certainly differentiates between the ‘covering’ senses of *over*, which vary in terms of the density of covering from ‘distributive location’ (e.g., *EXIST*) through ‘multiplex path’ (e.g., *DRIFT*) and ‘lacunal covering’ (e.g., *SPREAD*) to ‘concealing covering’ (e.g., *GLOSS*). In addition, the nouns before and after the preposition are involved in conveying the meaning of the phrase. Although the verb is considered the core of the phrase, in some cases the verb, in particular, such basic verbs as *COME* and *GO*, is unlikely to be a

deciding factor of the meaning of the phrase. Rather, some types of noun contribute decisively to the meaning. According to my corpus data, the HA combination is frequently found with *COME into* followed by *being* and *existence*, whereas the AA combination with *COME into* occurs with a wider variety of preceding nouns, such as *coherence*, *proposal* and *power*, and following nouns, such as *effect*, *force* and *play*. The combination of the preposition with nouns as well as with verbs makes it easier to provide a comprehensive account of the sense of the preposition and its environment. Admittedly, this study is unlikely to reveal whether prepositions have an independent meaning; however, it reveals that co-occurring verbs and nouns are both involved in specifying the sense of prepositions.

The sense of the preposition may be interpreted by means of such collocations as the co-occurring nouns and verbs. Resolving the polysemy of prepositions is unlikely to be based on the preposition alone, but the phrase containing the preposition and its collocations allows the preposition to be interpreted in different senses. The sense of the preposition is determined by a particular pattern. For example, the CC combination tends to occur with the preposition denoting the locative sense, whereas the HA combination is frequently found with the preposition conveying human relationships and activities. The phrase helps us to identify one particular sense of the preposition, although the preposition on its own looks polysemous. Moreover, a strong version of my hypothesis could be made: the preposition intrinsically has only the sense of its prototype, such as the penetration sense of *into* and the traversal sense of *through*. Noun and verb collocations may trigger an interpretation of the prototypical sense where it is extended into a metaphorical one. For example, the temporal sense, as in *at seven*, can be interpreted as a place on a timeline as a result of the synthesis of the locative sense of

the preposition with the collocation of a noun indicating time. Such semantic extension is conventionalised, and then we may consider prepositions as polysemous. Collocations are likely to make us see the preposition as if it had polysemous senses, although the polysemy may be due to the collocation, and not to the preposition.

8.2 The HCA combinations and semantic network

The semantic network of polysemy depicts the relationships between the senses of a word. The diagram of the semantic network seems to illustrate two possible hypotheses in cognitive linguistics (Figure 8.3 below). One hypothesis is that the semantic network consists of the central sense and the peripheral senses. The central sense is the prototype of the polysemous word, while the peripheral senses semantically derive from the prototype. Take *over*, for example. The central sense of the semantic network is the locative sense of location above¹, while the other senses are the peripheral senses surrounding the central sense in the semantic network. The other hypothesis is that the peripheral senses are derived from the central sense. The peripheral senses of *over*, ‘covering’ and ‘examining’ for example, are assumed to derive from the prototypical sense of locating above. When something is covered, another thing is located on or above it. When we examine a document, our eyes are located above it.

The HCA combinations are compatible with both hypotheses. Regarding the first hypothesis of the central and peripheral senses, the combinations of the concrete TR and the concrete LM, on the one hand, are likely to be the collocates of the central sense of prepositions, which closely relate to the embodied experiences of the spatial configuration in which concrete entities tend to be involved. In other words, the CC

¹ The central sense is coined as ‘proto-scene’ in the semantic network of *over* by Tyler and Evans (2003a: 80) on the basis of linguistic evidence (see section 5.1).

combination can predict the central sense of the preposition. On the other hand, the combinations containing an abstract TR or LM, such as CA, HA, AC, AH, or AA, are likely to co-occur with the peripheral senses of prepositions, which are not experienced bodily, since the configuration is metaphorical. Likewise, the combinations containing an abstract TR or LM can predict the peripheral senses of prepositions. As a result, the HCA combinations can differentiate the central from the peripheral senses of prepositions, not by a subjective interpretation of the preposition, but objectively by the collocates of the preposition.

As for the second hypothesis, the derivation from the central sense and the peripheral senses can also be explained by the HCA combinations. It may be supposed that the derived senses are projected from the locative sense onto a metaphorical domain in which the abstract TR and LM are involved. While the CC combination tends to occur with the locative sense, the CA and HA are likely to be seen with the derived sense in which the abstract LM is the target of a metaphorical projection from a concrete entity. For example, the abstract LM, *the future* as in (1), is metaphorically implied as the target of penetration by the TR, *large brown eyes*. In terms of the AA combination, the relationship between the abstract TR and the abstract LM is interpreted more metaphorically than the CC and CA combinations are. As in (2) below, the preposition *into* indicates the direction of penetration from *expectations* to *disappointment*, and at the same time the phrase is interpreted as a metamorphosis from one abstract entity to the other. Hence, the continuum from the CC through the other combinations to the AA is likely to show its derivation from the central, locative sense to the metaphorical senses of prepositions.

- (1) The second Alistair was a large, impressive man, with a square face, a

blunt nose and a slit of a mouth, contradicted by large brown eyes which appeared to be good naturedly looking into the future. <W2F-017 #062>

- (2) Thirteen days he calculated would allow as it were, just allow such expectations like boredom with it [sic.] melt into a vague disappointment,... <S1A-020 #111>

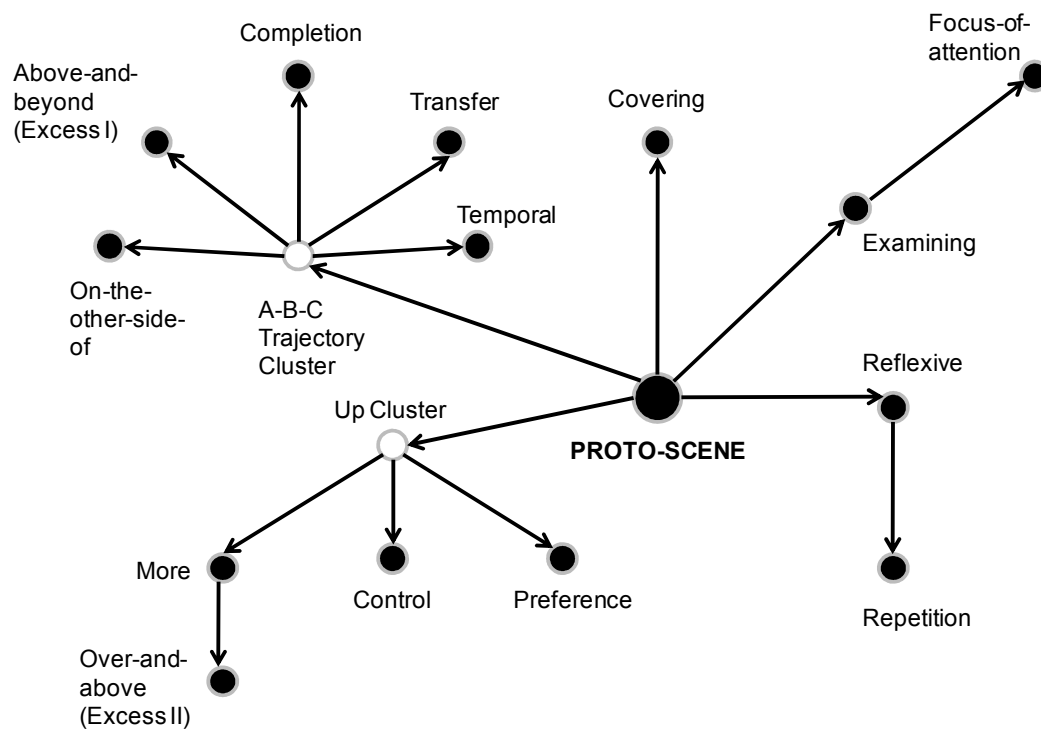

Figure 8.3 The semantic network for *over* (Tyler and Evans, 2003a: 80)

The appeal of the semantic network proposed by Tyler and Evans (2003a) lies in the way that it makes explicit the semantic associations between the various senses by means of semantic ‘clusters’, which gather the senses sharing the same concept. The A-B-C trajectory cluster groups the senses of ‘on-the-other-side’, ‘above-and-beyond’, ‘completion’, ‘transfer’ and ‘temporal’. The ‘up’ cluster includes the senses of ‘preference’, ‘control’ and ‘more’ with another subordinate derived sense, ‘over-and-above’. The clusters also suggest an extension from the prototypical sense to

the derived senses. In terms of the polysemy of the preposition, the locative sense is considered the prototype. The senses of the preposition share a common feature of having central and peripheral members in their network. The cluster associates them in the category of *over*, *into* and *through*, for example. The senses belong to the comprehensive category of the preposition.

The clusters in the semantic network can indicate the semantic elements of the preposition. If language users are asked what their concept of the sense of *over* is, such clusters as A-B-C trajectory and up are likely to be the archetypal concepts of the preposition. As was introduced in section 2.3, Beital *et al.* (1997) point out that language users perceive the locative sense of *on*, as in *The vase is on the table*, by referring to the subdivided concepts of the sense, SUPPORT, PRESSURE, VISIBILITY, COVERING and CONSTRAINT. Likewise, the A-B-C trajectory cluster can be the underlying concept of the senses of ‘completion’, ‘transfer’ and ‘temporal’ of *over*, for example. These senses seem to derive from the concept of movement from one to the other, which is defined as the A-B-C trajectory. I find it intriguing that the clusters of *over* are unlikely to be made randomly; rather, the concepts of the clusters appear to agree with the image schemas² (see the list of image schemas in Table 2.2 in section 2.3). The A-B-C trajectory corresponds to the path schema, as does the up to the scale schema. The semantic network of *into* which I established from the corpus data has a collision cluster which seems to be related to the blockage schema. The blockage schema also seems relevant to the impediment schema of *through*. These relationships between the clusters and the image schemas imply that the non-central senses of prepositions are likely to develop through image schemas.

² Image schemas are conceptual templates to help us to understand spatial and abstract configurations (see section 2.3).

The peripheral senses of the semantic network differ considerably in meaning, although they are expressed by the same orthographic form. The senses of the A-B-C trajectory cluster, on the one hand, denote physical and metaphorical movement from one place through mid-point to another: the on-the-other-side sense, as in *The cat jumped over the wall*, and the completion sense, as in *...the fighting is over relatively quickly* <W2E-006 #084>. On the other hand, the senses of the ‘up’ cluster convey abundance and superiority and movement is irrelevant to them. However, these different senses are verbalised by *over*. Family resemblance is a theory which holds that a category brings its members together by the different attributes which are shared by at least some of the members (Rosch, 1975). Based on the theory of categorization, the semantic network is likely to be composed of more than one attribute. I would argue, on the basis of the analysis so far, that one feature of the prototypical sense may be foregrounded, resulting in the derivation of the central sense, and the foregrounded feature becomes the cluster of the semantic network. The different features of the locative sense bring the polysemous senses together in the group of senses expressed by the same orthographic form. The semantic network of the preposition is established by the clusters which are associated with the senses, and we may understand the senses through the clusters.

The semantic network of prepositions seems to suggest that polysemy develops from a central sense, which tends to be locative or associated with movement, to the derived senses, which are metaphorical. As shown above in the semantic network of *over* in Figure 8.3, the proto-scene, indicating the locating above sense, is located at the centre. The other senses are developed through the clusters to the metaphorical senses. I apply the HCA combinations of the nouns co-occurring with the prepositions to

establish the semantic networks of *through* and *into*. This application is based on the hypothesis that the polysemous senses of the prepositions correspond to their linguistic environments, in particular the noun combinations before and after the preposition. As the above suggests, a correlation between the senses of the prepositions and the combinations of the preceding and following nouns can be observed. I hypothesise that the frequency of the HCA combinations of the senses can give a rationale as to where the derived senses are placed in the semantic network.

The semantic network of *over* by Tyler and Evans (2003a), shown above in Figure 8.3, seems unlikely to have a specific rationale underlying the position of the clusters and the peripheral senses. For example, the A-B-C cluster and the up cluster are placed on the left of the network, while the senses of covering, examining and focus-of-attention are at the top on the right. However, except for the extension from the centre to the periphery, there appears to be no particular reason for where the senses should lie. The HCA combination provides a possible rationale for the positioning of the senses in the diagram. As shown below, the frequent combinations of the nouns assign the senses to their place in the semantic network. The senses co-occurring with the CC combination are located at the top on the left of the network, whereas those with the HA combination are further down on the right. This positioning illustrates that these senses are used in a different linguistic environment. In other words, different collocations are seen in the senses of these combinations. Again, the combination of the co-occurring nouns can predict the sense of the preposition. The linguistic environment, which represents collocation and pattern, tells us which one of the polysemous senses to use in our interpretation.

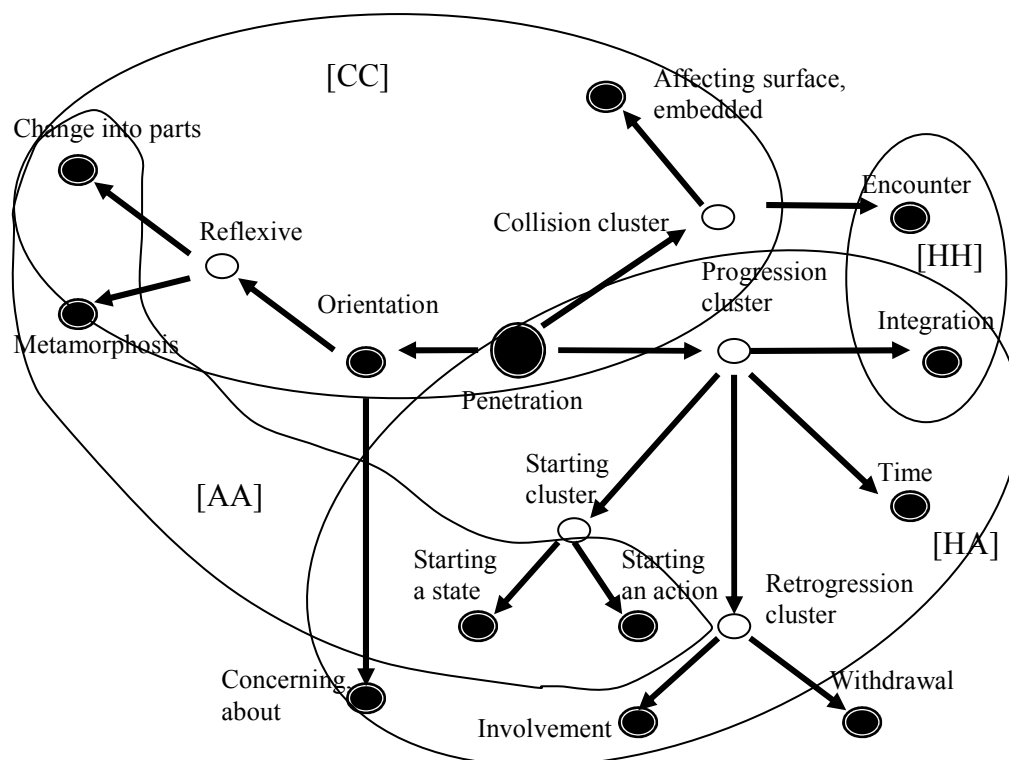

Figure 8.4 Domains of the HCA combinations of *into*

At the same time, the domains of the HCA combinations in the semantic network demonstrate the way in which the central sense and the clusters at the near-centre develop into the metaphorical senses. It is argued in cognitive linguistics that the category expands radially from the centre to the periphery. My semantic networks of *into* and *through* formulated from the corpus data have a tendency to form radial categories (Figure 8.5 below). It is surprising that the extension from centre to periphery of the HA combination goes further towards the metaphorical senses. Prepositions are prone to be related to the locative sense; however, the radial extension reveals that so many human activities in metaphorical settings, as well as physical ones, are expressed by prepositions. In conclusion, the HCA combinations give rise to a semantic network of the prepositions which brings into play the theories of prototype,

trajector and landmark, family resemblance and radial category.

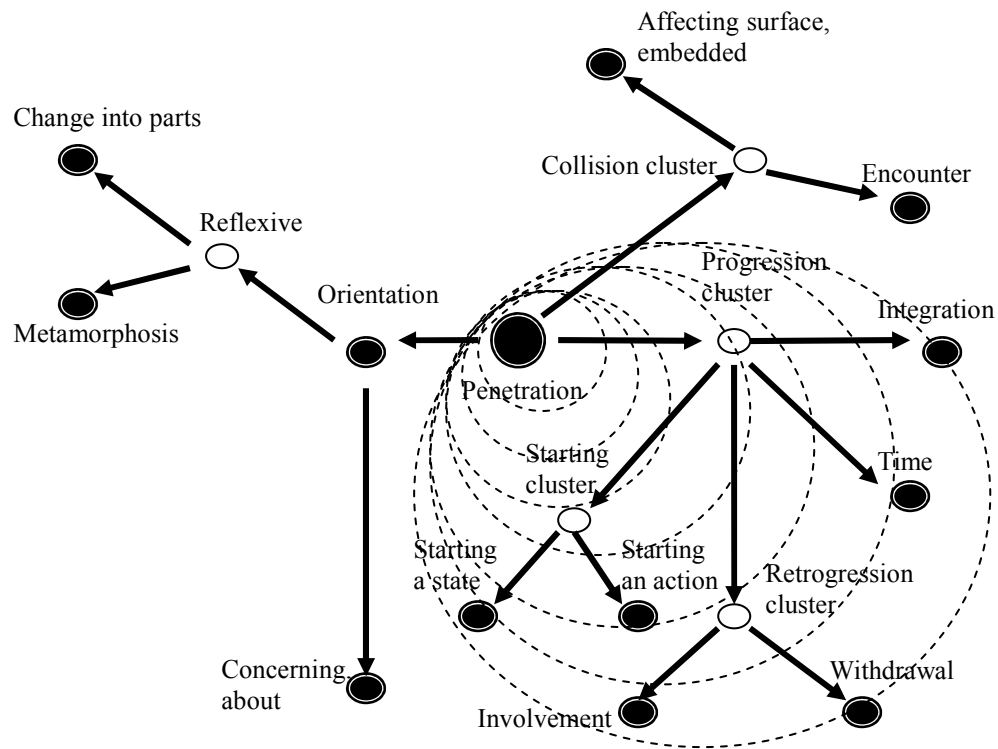

Figure 8.5 Radial category of the HA combination of *into*

To sum up, the HCA combinations have supplemented the conventional semantic network by giving reasons for the particular allocation of the clusters and the peripheral senses as well as showing a radial extension within the semantic network. The HCA combinations demonstrate the correlation between the senses and the co-occurring nouns, as the theory of phraseology in corpus linguistics postulates a relationship between collocation and sense. As a result, I would like to propose that HCA combinations constitute a robust indicator concerning the polysemous nature of prepositions. In the following section, I discuss the way in which metaphor is related to semantic extension and consider whether there is a tendency for this to be extended in the different prepositions.

8.3 Metaphor in the semantic network

Prepositions have not only physical senses in the semantic category but also metaphorical ones. As we saw in the analyses of *over*, *into* and *through* in Chapters 5, 6 and 7 respectively, the senses of the prepositions illustrated in the semantic networks are not only physical and locative but also to a large extent metaphorical. The metaphorical senses are used in a number of settings in which human activities and feelings are described. It is argued that the locative and movement sense of prepositions, which is located at the centre of the semantic network, is developed into the metaphorical senses. In other words, the metaphorical senses of prepositions can be derived from their ‘physical senses’. This is a unique feature of the semantic network of prepositions and makes this semantic network of prepositions different from the category of artefacts and animals. The senses of a preposition as a member of its category do share the prototypical sense to varying degrees. For example, according to the semantic network (Figure 8.3 above), the locative sense of *over* denoting locating, above, develops into the sense of more, as in *...twenty teaching jobs will be cut in order to save over four hundred and fifty thousand pounds* <S2B-015 #076>. The semantic attribute of ‘locating over’ is partially possessed by this ‘more’ sense. The ‘more’ sense is also extended into the ‘over-and-above’ sense, as in *I’m just watching the potatoes boil over*³ <S1A-016 #337>. The semantic attribute of the prototype is partly shared by the members of the category, namely the derived senses.

The semantic network is established by metaphorical extension from the prototype. The clusters within the semantic network are likely to be involved in the extension to the peripheral senses. I would argue, from analyses of the semantic

³ *Over* here is not a preposition but an adverbial particle. The example of the reference of the semantic extension is extracted from my corpus data.

network, that the clusters are likely to motivate the semantic extension. As the previous section argues, the clusters are likely to constitute the key elements of the derived senses. The metaphorical senses of the prepositions are developed from the prototypical sense through the clusters. My argument is that the clusters of metaphorical senses may emerge from image schemas, which are the conceptual templates of our cognition. The semantic network of the prepositions encapsulates the way in which we relate the locative sense to the metaphorical senses. In the semantic network of *into*, the collision cluster derives from the prototypical penetration sense and extends into the affecting surface/embedded sense and the encounter sense. As for *through*, the impediment cluster derives from the prototypical traversal sense and extends into the metaphorical senses of obstacle and success. Both clusters of the prepositions are likely to be based on ‘the blockage schema’ (Johnson, 1987: 126, see Table 2.2 in section 2.3), indicating that the trajector is stuck on the surface of the landmark. This image schema helps us to project the semantic extension of blockage onto the prototypes, which results in the derivation of the metaphorical senses. It can in turn be concluded that the semantic network to which I apply the HCA combinations can demonstrate the metaphorical extension from the prototype through the clusters to the derived senses.

A main argument in phraseology is that meaning is conveyed, not by individual words, but by the phrase formulated by the collocations, which specifies a particular meaning that tends not to be misinterpreted in communication. I agree with this proposition and then apply the HCA combinations of the co-occurring words to describing the senses of the prepositions. I can do so because the linguistic environment, namely collocations, can be used to identify the polysemous senses. This hypothesis has been revealed by the correlation between the noun combinations and the senses in

section 8.1 above. For the purpose of the analysis of metaphor into the senses of prepositions, the HCA combinations shed light on not only the linguistic environment but also the settings in which the senses are used. The HCA combinations are the collocations of the nouns co-occurring with the preposition. In addition, the nouns represent the agent and the target object, which are termed trajector and landmark, in terms of the configuration of the preposition. In other words, the HCA combinations indicate the setting of prepositions in which the trajector affects the landmark in the configuration. For example, Figure 8.6 below shows that the obstacle sense is frequently seen in a metaphorical configuration such as the HA and AA combinations; this sense is not found in the CC combination, although the sense of ‘obstacle’ may imply a physical impediment. The frequent combinations suggest that the obstacle sense is used in settings where a human or abstract trajector is obstructed by an abstract landmark, as in *And that's something we've got to work through* <S1B-044 #048>. The application of the HCA combinations to the semantic network is likely to provide a further description of the metaphor in the prepositional phrase, describing in particular the linguistic environment and the setting.

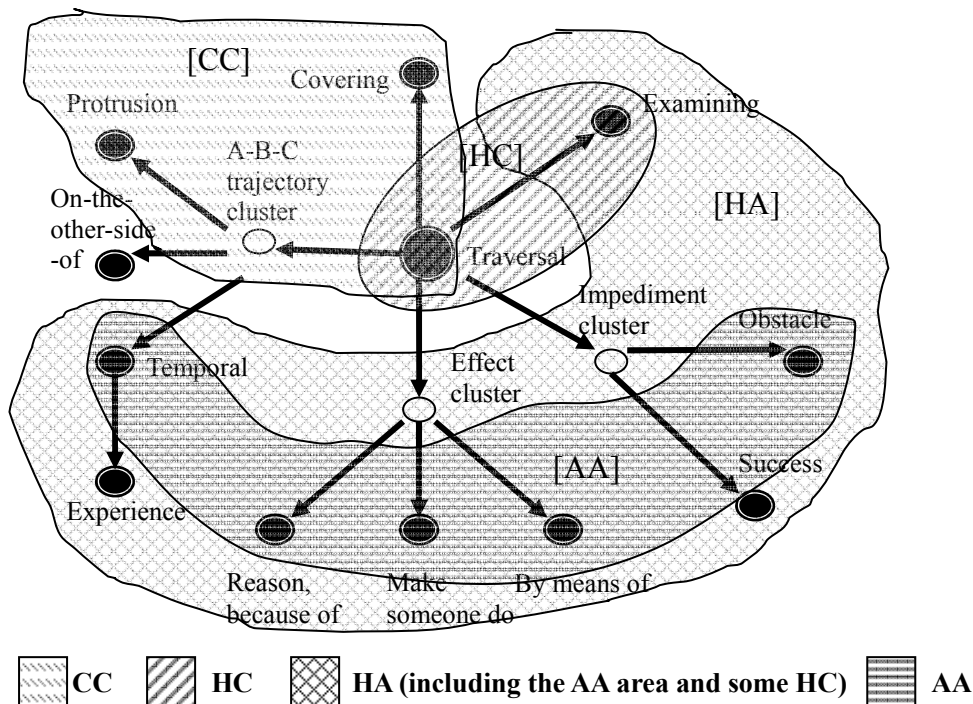

Figure 8.6 Domains of the HCA combinations of *through*

The HCA combination provides a robust indicator of collocation which can be used to describe the metaphorical senses of prepositions and their phrases. The combinations suggest the motivation for extending the sense from the locative into the metaphorical. First, the HCA combinations manage to display the mapping of a physical sense of the preposition onto a metaphorical setting. As shown in example (3) below, the ‘locating above’ sense of *over* is used in the CC combination. The configuration of ‘locating above’ can be mapped onto the metaphorical trajectors, such as *curse* in (4) and *threat* in (5). In these cases, while the configuration between the trajector and the landmark is spatial and concrete, the trajectors are abstract. So the phrases containing the locative sense *over* convey a metaphorical meaning. The spatial sense of the preposition and the abstract landmark are also observed in examples of *into*, such as (6) below.

- (3) A mist hung over the river. <W2F-013 #071>
- (4) Does some sort of curse hang over the place? <W2F-016 #069>
- (5) But it's a threat that still looms over him. <S2B-040 #064>
- (6) ...but as soon as I get into a conversation, the vocabulary that I know I must know and do know is back there somewhere. <S1A-044 #048>

Note that, although the meaning of the phrase is metaphorical, the sense of the preposition is not abstract, but rather spatial and prototypical. The metaphorical sense of prepositions is the derivation of the locative and movement senses. The HCA combinations of the nouns before and after the preposition help us to identify the metaphorical mapping of the spatial sense onto a metaphorical configuration. I would hypothesise that this kind of mapping occurs at the early stages of a semantic extension, which gradually develops into an independent metaphorical sense. For example, the temporal sense of prepositions may derive from the mapping of the locative sense onto an abstract landmark of time. The temporal sense of prepositions may not be an independent sense, but may be an interpretation of the locative sense with the abstract landmark of time.

As discussed above, the demarcation of the senses between the locative and the temporal is unlikely to be clear-cut and is probably fuzzy. My second hypothesis concerning the semantic extension of polysemy is that an independent sense of prepositions may be a metonymically highlighted part of the process of movement. Metonymy is a concept in cognitive linguistics which represents the foregrounding of a relationship. A well-known example of metonymy is given by Lakoff and Johnson (1980: 35): *The ham sandwich is waiting for his check*. As the possessive determiner *his* indicates, *the ham sandwich* refers to the customer who orders it and is foregrounded

from the relationship between the customer and the order. The prepositions *over*, *into* and *through* are based on the path schema, which is divided into the starting point, the mid-point and the end point. It seems to me that some of the derived senses refer to a part of the path and that part of the path process is highlighted as if it denoted an independent sense. For example, the affecting surface/embedded sense of *into*, which emerges through the collision cluster, seems likely to foreground the mid-point of penetration of the trajector into the landmark. As in (7) below, *the hieroglyphs* do not reach the end point of the path, which is the inside of *the limestone*, but they remain on the surface of the landmark. This is the mid-point of the path. This foregrounding of a part of the path may give rise to the affecting surface/embedded sense of *into*. Similarly, the protrusion sense of *through* is likely to be due to the foregrounding of the end-point. Example (8) indicates that the trajector, *cast-iron beam*, in particular its end part, is highlighted compared to the middle and the other end. Consequently, if these senses are ‘metonymical transformations’ of the penetration sense and the traversal sense respectively, the derived senses are, as a result, not independent senses as such, but rather subspecies of the prototypical senses.

- (7) And this as we have always said is the real measure of skill because **the hieroglyphs** here are incised into **the limestone**. <S2A-052 #070>
- (8) **A great cast-iron beam** protruded through **an opening high up** in the building. <W2F-007 #003>

The third hypothesis is that the metaphorical extension of prepositional senses is unlikely to be random, but rather is prone to extend into particular senses, such as those relating to time and human action. As shown in the semantic networks of *into* and *through* (Figures 8.4 and 8.6 above), the HA combination was found frequently and

with a number of senses. The HA combination with *into* was seen in 10 senses out of 14 and was more frequent than any other combination. Likewise, the HA combination with *through* was the most frequent of all of the combinations (9 senses out of 12). This implies that human activity towards an abstract landmark is frequently spoken and written about. It also implies that human activity is pervasive not only in a physical setting but also in a metaphorical one. The temporal sense is a good example of the metaphorical extension of the physical, locative sense. Although time is an abstract concept, we perceive it as something physical or spatial. As discussed in section 2.4, we see time either as moving (the moving time model) as in *Christmas is getting closer* (Evans, 2007b: 753), or as ourselves moving towards it (the moving ego model) as in *We're getting closer to Christmas*. This perception is likely to derive from the metaphorical mapping of a physical path onto an abstract timeline. Similarly, human activity is extended into an abstract domain. For example in (9), illustrating the experience sense of *through*, people cannot physically go through a *divorce*, but we somehow perceive it as something which we might traverse. And in (10), showing the start of an action sense of *into*, while people cannot physically go into *paying the poll tax*, we still perceive it as something which we could enter.

(9) Uh, now he's just going through a divorce again. <S1A-076 #042>

(10) But the chairman of Brent Against The Poll Tax, Theresa Dean, slated the proposal, saying: 'This is a bribe to lure people into paying the poll tax'. <W2C-009 #050>

To sum up this section, the HCA combinations and the semantic networks contribute to the discovery of the elements of semantic extension which closely relate to metaphor. The cluster is likely to associate the spatial sense with the metaphorical

senses and gives rise to semantic extension into the metaphorical senses. The HCA combinations in the semantic network suggest three hypotheses concerning the metaphorical behaviour of prepositions: motivation, metonymy and a general tendency towards extension. The spatial sense is metaphorically motivated by mapping onto an abstract domain. Specifically, the locative sense is projected, maintaining a spatial configuration onto a conceptual timeline which results in it being interpreted as the temporal sense. Metonymy, whereby a part of the path scheme is foregrounded, is ubiquitous in the derived senses. Human activities are expressed by many derived senses of prepositions, as well as the temporal sense. This has been suggested by the high frequency of the HA combination in the semantic networks of *into* and *through*.

8.4 Applications of the results and limitations

The results of this study suggest that the trajector and landmark collocations can predict the sense of a co-occurring preposition to the extent that, although no one-to-one relationship exists between one combination and the sense of the preposition, a certain type of combination does tend to occur with particular senses. Three applications for this finding can be cited: accounts in dictionaries, machine translations and the teaching of English as a foreign language. Although collocation has been used in the description of phrases in dictionaries and textbooks of languages, the relationship between the sense of prepositions and their collocates, which has been explored in this study, is likely to specifically point to one sense out of several possible senses by the linguistic behaviour.

Firstly, descriptions of collocations such as trajector and landmark can be used to provide detailed accounts of the senses of prepositions and contrast the polysemous senses more clearly. For example, *Collins Cobuild Advanced Learner's English*

Dictionary shows the senses of *over* by an example sentence, as in *a bridge over the river Danube*, giving an explanation of the sense which is paraphrased from the sense into a detailed description, such as *...the first thing is directly above the second, either resting on it, or with a space between them*, (Sinclair *et al.*, 2003: 1022). This locative sense is prototypical and most likely the basic sense of the preposition. However, some instances in my corpus data were found to metaphorically use the ‘locating above’ sense, which connotes domination by something negative, as in *Does some sort of curse hang over the place?* <W2F-016 #069> and *But it’s a threat that still looms over him* <S2B-040 #064>. The trajectors of abstract objects, such as *curse* and *threat*, in combination with the landmarks, such as *the place* and *him*, indicate the semantic extension of the locative sense into the metaphorical meaning of domination over place and person. The difference in the trajector-landmark combinations between the CC, such as *a bridge* and *the river*; the AC, such as *the curse* and *the place*; and the AH, such as *a threat* and *him*, indicate the semantic variation of the locative sense. Such differences in the senses could be described by classifying the collocations of the trajector and the landmark into the HCA combinations, and added to the description in the dictionary.

If information on the HCA combinations is provided, it becomes less difficult to interpret the polysemous preposition correctly. In Japanese, for example, the equivalent of all three prepositions *at*, *on* and *in* is only one particle, *ni*. It is thus difficult for Japanese learners of English to choose which preposition to use. Also, when reading and listening to English, learners find many ways to interpret prepositions, due to the difficulty of specifying the sense of prepositions according to the context. The context provided by the phrases and sentences tells us which sense of the polysemous

preposition is to be inferred. However, the HCA combinations, composed of the trajector and the landmark, can specify one of the senses, whereas the context depends more on many other components, such as the preceding and following sentence and paragraph, than on the trajector and the landmark. The minimum number of components of the context, trajector and landmark, can predict a particular sense of the polysemous preposition.

Secondly, the HCA combinations may contribute to the development of machine translation. If the HCA tags are annotated to the trajector word and the landmark word, the interpretation of the preposition could be more accurate than it is when one translates the preposition without referring to the combination of collocations. A conventional machine translation tends to translate one word into its equivalent in another language. One-to-one word translation of polysemous word poses problems for machine translation as the computer does not know which sense to choose. Interpretation with the help of collocations, namely the HCA combinations, can narrow the choice of the sense of the preposition according to the context. As has been discussed, the context containing the prepositional phrase is to a certain extent reflected in the combination of the trajector and the landmark. The classification of the HCA combinations is represented as a process of context interpretation. Every single word of the sentence containing a preposition is involved in interpreting the preposition. As shown in this study, not only the co-occurring nouns but also the verb, the article and the clause structure as represented by the passive voice, for example, appear to be related to the interpretation of a particular sense of the preposition. It may be difficult to associate all the co-occurring words with a particular sense, because too many variables are unlikely to help the algorithm of machine translation to work efficiently. The HCA

combinations are so simple that only two nouns co-occurring with a preposition give any indication of context to determine the sense of the preposition.

“Tags are more than just keywords but symbols for personal concepts” (Adrian *et al.*, 2007: 298). A part-of-speech tag is a representation of the grammar concept of language on the hypothesis that we categorize words on the basis of grammar. If HCA combination tags were to be established, they would symbolise our conception of a spatial configuration and a metaphorical one. In other words, our construal of the relationship of two entities mediated by a preposition could be shown by the HCA combinations. When we see a relationship of two concrete objects, it tends to be interpreted as a spatial configuration. In contrast, the involvement of an abstract object in a relationship indicated by a preposition is often interpreted as the metaphorical sense, which is semantically extended from the locative sense. For example, in *Uh, now he's just going through a divorce again* <S1A-076 #042>, an imaginary path movement for *him* to go through *a divorce* is interpreted as the experience sense of *through* as a semantic extension from the physical path movement. The HCA combinations are not only tags to facilitate a more accurate translation of prepositions; rather, they are the representation of our concepts in terms of interpreting the configurations indicated by the prepositions. However, is our construal of the relationships of prepositions so straightforwardly classifiable into human (H), concrete objects (C) and abstract objects (A)? The three categories of the HCA may not be precise enough to represent our classification of the trajector and the landmark of prepositions. Such limitations are discussed in detail later in this section.

Thirdly, the HCA combinations may be a powerful tool for enhancing the study of English as a second language. As a learner of English, I struggle to master the use of

prepositions. The reason for the difficulty is that the use of prepositions is not clearly explained in grammar books and the rules of their usage seem to reflect conventionalities of the language. These conventionalities seem to largely depend on the innate judgement of language users. Native speakers can confidently tell which sense is being conveyed and which preposition is appropriate. Such judgements are unlikely to be classifiable under the rules of 'correct English' and it is hard for language learners to acquire the necessary sensibility. However, I believe that the HCA combinations make the process of judgement explicit by focusing on the classification of the trajector and the landmark co-occurring with a preposition. Similar to the application for dictionary definitions, the classification of the trajector and the landmark, rather than interpreting the preposition alone, may help learners identify which of the polysemous senses of the preposition is relevant. The indication of the pattern containing the HCA combination and the preposition may encourage learners not to puzzle over the various possible choices among the several senses of the preposition. Moreover, the teaching of prepositions in English language classrooms would change. Teachers could encourage learners not to focus on the preposition alone when interpreting it, but to direct their attention to the collocations, the HCA combinations in particular. Interpreting prepositions with the help of the collocations can be beneficial for helping learners to realise the semantic associations of the words in the phrase.

The semantic networks of *into* and *through* based on the distribution of the HCA combinations have been presented in this study. These diagrams of the polysemous senses may also help learners to learn the semantic extension from the locative sense to the metaphorical one. Those semantic networks illustrate the semantic development of the locative sense of the prepositions and similar senses are placed in

the same domain of the HCA combinations, according to their distribution. For example, while the penetration sense and the senses of change of state and collision of *into* are placed in the CC combination domain of the semantic network, the senses of encounter and integration of *into* are in the HH combination domain (see section 6.4 Figure 6.20). Therefore, the collocations represented by the HCA combinations may encourage learners to systematically understand the polysemous senses of prepositions following the way in which similar senses are found with the same HCA combination. Raising a language learner's awareness of metaphor in semantic extension is likely to enhance their understanding of the use of prepositions (Littlemore, 2009).

The HCA combinations, which are the main contribution of this study to linguistic applications, have some limitations. As mentioned above, the classification into the HCA may not be finely enough grained to reflect our construal of the relationship of prepositions. For the purpose of statistical tests, the categories of this study were restricted to three, namely, human, concrete object and abstract object. Schönefeld (2006: 307) applies five categories to classify the trajector in relation to posture verbs: human beings, concrete objects, abstract objects, personified objects and animals. In this study animals are regarded as animate and fall into the human category which includes animate living things, but flowers and plants are excluded from this and are instead categorized as concrete objects. In terms of categorization, scientific taxonomies do not always agree with our subjective classification in language (cf. linguistic and encyclopaedic knowledge, Taylor, 2003:85). In Japanese, living fish and dead fish are spoken of different ways, whereas in English the contrast is between meat in the cooking context and in the farming context: 'beef' and 'pork' as opposed to 'cow' and 'pig'. In addition to the HCA and Schönefeld's categories, these categories and any

others may be involved in classifying entities in language and determining the meaning of words.

8.5 Conclusion and future work

This study has explored the collocations of the polysemous prepositions, namely *over*, *into* and *through*, on the hypothesis that the collocations of the trajector (TR) and the landmark (LM) relate to the senses of the prepositions. The trajector and landmark are considered to compose a spatial configuration and represent our construal of the relationships of prepositions. I have used this theory from cognitive linguistics to discuss the relationships between preceding and following nouns as collocations with the preposition. Statistical tests have shown a correlation between the sense of the preposition and the distribution of the HCA combinations of the co-occurring nouns. These results imply that it is to some degree possible to describe the different senses of prepositions by referring to the collocations of the trajector and the landmark. Hence, the hypothesis of cognitive linguistics that the TR and the LM are related in the configuration of prepositions has been supported by the corpus evidence. Equally, it was found that the association of the collocations of the TR and the LM was supported by hypotheses from cognitive linguistics. As suggested in the introduction to this thesis, it turns out that corpus linguistics and cognitive linguistics complement each other in describing the polysemy of prepositions.

Some future research projects can be suggested in the light of this study. First, the cognitive processes of metaphor and metonymy in the polysemy of prepositions await further examination. As has been seen in the analyses in this study, metaphor is ubiquitous in the semantic extensions of the derived senses of prepositions. The

extension is unlikely to be random and indeed seems to be logically structured according to image schemas (see section 8.2). As regards metonymy, it appears that highlighting a part of the path movement results in establishing a derived sense: for example, the end-point of the path movement is highlighted when the affecting surface sense of *into* is conveyed, as in *...Lambert's Daimler crashed into a sports car...*<S2B-017 #055>. Investigating the sense in which such metonymical highlighting occurs will probably explain our construal when interpreting spatial configurations.

Second, we should examine how far idioms prevail over TR and LM combinations. Prepositions tend to be treated as part of an idiom which is considered as a fixed phrase. Unlike my hypothesis of the combination of TR and LM, the preposition in the idiom seems to lessen a semantic association with the TR, since the association of the words in the idiom phrase seems relatively stronger. For example, in *...as heavy investment and speedier servicing of customers in Europe came into play...*<W2C-005 #079>, it seems that the LM, *play*, does not occur in relation to the TR, *investment and servicing*; instead, *play* occurs as an idiom, *COME into play* (Hunston, personal communication). Although this may be so, my corpus data suggest that only certain types of word, such as abstract objects, co-occur with the idiom. Hence, the choice of the TR (or the subject phrase) is to a certain extent restricted in relation to the idiom containing the LM.

Third, establishing the semantic network of prepositions by non-native speakers may differ from that by native speakers. Different mother languages are likely to affect the interlanguage in the acquisition of a second language (Granger, 1998). This study focuses on the semantic networks of native English speakers, whereas using HCA combinations could uncover the semantic network of the interlanguage of learners of

English. Comparing these semantic networks would indicate which senses and combinations are underused in the acquisition of English and what types of semantic extension are difficult to develop in the interlanguage concerned.

My present journey of research ends with this comment. The classification of the TR and the LM has the potential to describe the senses of words and suggests that meaning is not conveyed by one word alone, but rather by phrases composed of collocations. This finding helps me understand the polysemy of prepositions and a possible way for native speakers of English to tell which sense is conveyed. However, it is highly likely that more than the TR and LM combination is involved in establishing the meaning of preposition-centred phrases. Some uses of the phrases can be explained only as conventional uses. The use of language and the minds of language users seem to be distant, but I hope that this study begins to bridge the gap between these two aspects of linguistics.

Appendix 1: Enquiries and questionnaire concerning classification (Chapter 3)

Human (animate), concrete object and abstract object classification

Your first language is _____

Please write H (human), C (concrete object) or A (abstract object) under the shaded words.

- (1) I suppose that statistic which you gave eighty per cent of, the population wanting to go into the countryside there's a great change that has taken place since the motorcar really because at the beginning of the century for instance people would have gone.
- (2) and in this case because everything was done in a bit of a rush uh then she just appointed people she knew who were active in the union and who came into the faculty of arts,
- (3) The eight bands will now form into close columns and divisions for the march off.
- (4) At present a company wanting to take over another has to show that it is not against the public interest.
- (5) ... Third World countries and which have displayed rapid economic and industrial growth over the past three to four decades.
- (6) He said the United Nations had no control over the military action
- (7) And they lead to forces acting on the structural elements which are usually then distributed through the height of the building.
- (8) The sound of one of Avignon's many choirs echoes through the stone arches of the cathedral,
- (9) As they come into the final bend now it's going to be Chris Louis who takes the chequered flag.
- (10) Nerve injuries have been classified into various grades and these are discussed below.
- (11) Propellant took up 75 per cent of the V-2's take-off weight, enabling it to achieve a maximum speed of 3,500 miles per hour (5,600 kilometres per hour), only one-fifth of the velocity needed to go into orbit.
- (12) Again, power is obtained by transferring the weight forwards, so try to step into the shot.
- (13) Uhm the voices are coming over quite loud over the cans.
- (14) And,, I must have been looking through one of my old notebooks from Cambridge or something before I was telling him about it.
- (15) We'll run through the Arsenal line-up.
- (16) Just to run through the batsmen who scored the runs Taylor four Benson

forty-three Hinkstweny-five in only twenty one twenty-one balls Graham Cowdry
fifteen Nigel Long five Matthew Flemingthat delightful fifty-one Steve Marsh six.

(17) And so, on 28 May, having spent fourteen weeks in the Marshalsea, John Dickens
was released into the world.

(18) It's clear the coalition is not in a mood to negotiate over its demands with the main
issues expected to be resolved tomorrow.

Thank you very much for your help.

Yoshi

QUESTIONNAIRE OF SENSES OF PREPOSITION

I wonder if you would mind spending two minutes to help me with my PhD research? The senses of prepositions seem to be on a continuum from literal to metaphorical. Would you put the senses of *into* in the following nine sentences IN ORDER on this continuum? Please give each sentence a number from 1 (the most literal, or the most concrete and material) to 9 (the most metaphorical); would you write this number in the bracket before the sentence?

- () *It was when Charles came into the room.*
- () *The door opened directly into the living room.*
- () *Mr Les Crewes, whose daughter Joanne died when Lambert's Daimler crashed into a sports car last May, said he had no sympathy for the man behind the wheel.*
- () *Guy, how did you get into this business of theatre composing?*
- () *In the deepening recession good companies as well as bad are being plunged into liquidity problems.*
- () *He told his audience that a common currency could evolve into a single currency but only as a result of the choice of governments and peoples and not by imposition.*
- () *Panathinaikos to their credit have brought a positive approach into this game.*
- () *The immense power of chemicals has seduced us into believing that we can lord it over nature.*
- () *A government inquiry was set up in 1934 to look into the future of television broadcasting and decided that a service should be set up and run by the BBC.*

Thank you very much for your help.
PhD student of English Department, Yoshi KAMAKURA

REFERENCES

- Adrian, B., Sauermann, L., & Roth-Berghofer, T. (2007). *ConTag: A semantic tag recommendation system*. Paper presented at the I-MEDIA 07 and I-SEMANTICS 07 Conference, Graz, Austria.
- Allwood, J. (2003). Meaning potentials and context: Some consequences for the analysis of variation in meaning. In H. Cuyckens, R. Dirven & J. Taylor (Eds.), *Cognitive approaches to lexical semantics* (pp. 29-66). Berlin: Mouton de Gruyter.
- Anscombe, G. M. E. (2002). The intentionality of sensation: a grammatical feature. In A. Noë & E. Thompson (Eds.), *Vision and mind: selected readings in the philosophy of perception* (pp. 55-75). Cambridge, Mass./London: MIT Press.
- Barcelona, A. (2000). On the plausibility of claiming a metonymic motivation for conceptual metaphor. In A. Barcelona (Ed.), *Metaphor and metonymy at the crossroads: A cognitive perspective* (pp. 31-57). Berlin: Mouton de Gruyter.
- Beitel, D., Gibbs, R., & Sanders, P. (1997). The embodied approach to the polysemy of the spatial preposition *on*. In H. Cuyckens & B. Zawada (Eds.), *Polysemy in Cognitive Linguistics: Selected Papers from the Fifth International Cognitive Linguistics Conference* (pp. 241-260). Amsterdam: John Benjamins.
- Bennett, D. C. (1975). *Spatial and Temporal Uses of English Prepositions: An Essay in Stratificational Semantics*. London: Longman Group Limited.
- Berlin, B., & Kay, P. (1969). *Basic Color Terms: Their universality and evolution*. Berkeley Los Angeles: University of California Press.
- Biber, D., Conrad, S., & Leech, G. (2002). *Longman Student Grammar of Spoken and Written English*. Harlow: Pearson Education Limited.
- Biber, D., Conrad, S., & Roppen, R. (1998). *Corpus Linguistics: Investigating Language Structure and Use*. Cambridge: Cambridge University Press.
- Boers, F. (1996). *Spatial Prepositions and Metaphor: A cognitive semantic journey along the UP-DOWN and the FRONT-BACK dimension*. Tübingen: Gunter Narr Verlag.
- Bowerman, M. (1996). Learning how to structure space for language: a crosslinguistic perspective. In P. Bloom, M. Peterson, L. Nadel & M. Garrett (Eds.), *Language and space* (pp. 385-436). Cambridge, MA: MIT Press.
- Brugman, C. (1981). *Story of "over"*. Unpublished MA thesis, University of California, Berkeley.
- Brugman, C. (1988). *The story of over: Polysemy, semantics and the structure of the lexicon*. New York: Garland Press.
- Brugman, C., & Lakoff, G. (1988). Cognitive topology versus semantic features. In S. L. Small, G. W. Cottrell & M. K. Tane (Eds.), *Lexical Ambiguity Resolution: Perspectives from Psycholinguistics, Neuropsychology and Artificial Intelligence* (pp. 479-508). San Mateo: CA: Morgan Kaufmann Publishers.
- Bybee, J., & Hooper, P. (Eds.). (2001). *Frequency and the emergence of linguistic structure*. Amsterdam: John Benjamins.
- Carroll, M. (1997). Changing place in English and German: language-specific preferences in the conceptualization of spatial relations. In J. Nuyts & E. Pederson (Eds.), *Language and Conceptualization* (pp. 137-161). Cambridge: Cambridge University Press.
- Casasanto, D., & Boroditsky, L. (2008). Time in the mind: Using space to think about time.

- Cognition*, 106, 579-593.
- Choi, S., & Bowerman, M. (1991). Learning to express motion events in English and Korean: The influence of language-specific lexicalization patterns. *Cognition*, 41, 83-121.
- Chomsky, N. (1975). *Reflections on language*. New York: Pantheon.
- Clark, E. (1973). Nonlinguistic strategies in the acquisition of word meanings. *Cognition*, 2, 161-182.
- Cowie, A. P. (1988). Stable and creative aspects of vocabulary use. In R. Carter & M. McCarthy (Eds.), *Vocabulary and Language Teaching* (pp. 126-139). London: Longman.
- Cowie, A. P. (1994). Phraseology. In R. E. Asher (Ed.), *The Encyclopedia of Language and Linguistics*. Oxford: Pergamon.
- Crane, T. (2001). Intentional objects. *Ratio*, 14, 336-349.
- Croft, W., & Cruse, D. A. (2004). *Cognitive Linguistics*. Cambridge: Cambridge University Press.
- Cuyckens, H. (1993). The Dutch spatial preposition "in": A cognitive-semantic analysis. In C. Zelinsky-Wibbeh (Ed.), *The Semantics of Prepositions: from mental processing to natural language* (pp. 27-72). Berlin/New York: Mouton de Gruyter.
- Cuyckens, H., Sandra, D., & Rice, S. (1997). Towards an empirical lexical semantics. In B. Smieja & M. Tasch (Eds.), *Human Contact Through Language and Linguistics* (pp. 35-54). Berlin: Peter Lang.
- Danielsson, P. (2003). Automatic extraction of meaningful units from corpora: A corpus-driven approach using the word stroke. *International Journal of Corpus Linguistics*, 8(1), 109-127.
- Day, R. (2000). The "Conduit Metaphor" and The Nature and Politics of Information Studies. *Journal of the American society for information science*, 51(9), 805-811.
- Descartes, R. (1984). *The Philosophical writings of Descartes: vol. 2*. New York: Cambridge University Press.
- Dewell, R. (1994). Over again: image-schema transformations in semantic analysis. *Cognitive Linguistics*, 5(4), 351-380.
- Dewell, R. (2007). Moving OVER: The role of systematic semantic processes in defining individual lexemes. *Annual Review of Cognitive Linguistics*, 5, 271-288.
- Dirven, R. (1985). Metaphor as a basic means for extending the lexicon. In W. Parotté & R. Dirven (Eds.), *The Ubiquity of Metaphor* (pp. 85-119). Amsterdam: Benjamins.
- Dirven, R. (1989). Space Prepositions. In R. Dirven, W. Zydatis & W. J. Edmonson (Eds.), *A user's grammar of English* (pp. 519-550). Frankfurt: Peter Lang.
- Dirven, R. (1993). Diving up physical and mental space into conceptual categories by means of English prepositions. In C. Zelinski-Wibbelt (Ed.), *The Semantics of Prepositions: From Mental Processing to Natural Language Processing*. Berlin: Mouton de Gruyter.
- Dirven, R. (2003). Metonymy and metaphor: Different mental strategies of conceptualisation. In R. Dirven & R. Pörings (Eds.), *Metaphor and Metonymy in Comparison and Contrast* (pp. 75-111). Berlin/New York: Mouton de Gruyter.
- Dirven, R., Zydatis, W., & Edmonson, W. J. (Eds.). (1989). *A user's grammar of English: Word, Sentence, Text, Interaction*. Frankfurt am Main: Peter Lang.
- Evans, V. (2007a). *A Glossary of Cognitive Linguistics*. Edinburgh: Edinburgh University Press.
- Evans, V. (2007b). How we conceptualise time: language, meaning and temporal cognition. In V. Evans, B. Bergen & J. Zinken (Eds.), *The Cognitive Linguistics Reader* (pp. 733-766).

- London/Oakville: Equinox Publishing Ltd.
- Evans, V. (2009). *How words mean: Lexical concepts, cognitive models, and meaning construction*. Oxford: Oxford University Press.
- Evans, V., & Green, M. (2006). *Cognitive Linguistics An Introduction*. Edinburgh: Edinburgh University Press.
- Fauconnier, G., & Turner, M. (1998). Conceptual integration networks. *Cognitive Science*, 22(2), 33-187.
- Fillmore, C. J. (2008). A Valency Dictionary of English. *International Journal of Lexicography*, 22(1), 55-85.
- Firth, J. R. (1957). A synopsis of linguistic theory, 1930-1955. In J. R. F. e. al. (Ed.), *Studies in Linguistic Analysis* (Vol. Special Volume of the Philological Society, pp. 1-32). Oxford: Blackwell.
- Foster, P. (2001). Rule and routines: a consideration of their role in the task-based language production of native and non-native speakers In M. Bygate, P. Skehan & M. Swain (Eds.), *Research pedagogic tasks: second language learning, teaching and testing*. London/New York: Longman.
- Francis, G. (1993). A corpus-driven approach to grammar: principles, methods and examples. In M. Baker, G. Francis & E. Tognini-Bonelli (Eds.), *Text and technology: in honour of John Sinclair*. Philadelphia: John Benjamins.
- Francis, G., Hunston, S., & Manning, E. (Eds.). (1996). *Collins Cobuild Grammar Patterns 1: Verbs*. London: HarperCollins Publishers Ltd.
- Francis, G., Hunston, S., & Manning, E. (Eds.). (1998). *Collins Cobuild Grammar Patterns 2: Nouns and Adjectives*. London: HarperCollins Publishers Ltd.
- Freeman, N., Lloyd, S., & Sinha, C. (1980). Infant search tasks reveal early concepts of containment and canonical usage of objects. *Cognition*, 8, 243-262.
- Gardner, D., & Davies, M. (2007). Pointing out Frequent Phrasal Verbs: A Corpus-Based Analysis. *TESOL quarterly*, 41(2), 339-359.
- Geeraerts, D. (2007). Where does prototypicality come from? In V. Evans, B. Bergen & J. Zinken (Eds.), *The Cognitive Linguistics Reader* (pp. 168-185). London/Oakville: Equinox Publishing Ltd.
- Gibbs, R. W. (2006). *Embodiment and Cognitive Science*. Cambridge: Cambridge University Press.
- Gibbs, R. W., Beitel, D. A., Harrington, M., & Sanders, P. E. (1994). Taking a stand on the meaning of *stand*: Bodily experience as motivation for polysemy. *Journal of Semantics*, 11, 231-251.
- Givón, T. (1979). *On Understanding Grammar*. Cambridge, MA: MIT Press.
- Goldberg, A. E. (1995). *Constructions: A construction approach to argument structure*. Chicago: University of Chicago Press.
- Goldberg, A. E. (2006). *Constructions at work: the nature of generalization in language*. Oxford: Oxford University Press.
- Goossens, L. (2003). Metaphonymy: The interaction of metaphor and metonymy in expressions for linguistic action. In R. Dirven & R. Pörings (Eds.), *Metaphor and Metonymy in Comparison and Contrast* (pp. 349-377). Berlin/NewYork: Mouton de Gruyter.
- Gorman, M. (2006). Talking about intentional objects. *dialectica*, 60(2), 135-144.
- Grady, J. (1998). The "Conduit Metaphor" Revisited: a Reassessment of Metaphors for

- Communication. In J.-P. Koenig (Ed.), *Discourse and cognition: Binding the gap*. Stanford: CSLI publications.
- Grady, J. E. (1997). Theories are building revisited. *Cognitive Linguistics*, 8(4), 267-290.
- Granger, S. (Ed.). (1998). *Learner English on Computer*. Harlow: Addison Wesley Longman Limited.
- Gucht, F. v. d., Willems, K., & Cuypere, L. D. (2007). The iconicity of embodied meaning: polysemy of spatial prepositions in the cognitive framework. *Language sciences*, 29(6), 733-754.
- Gumperz, J. J., & Levinson, S. C. (1996). Introduction: linguistic relativity re-examined. In J. J. Gumperz & S. C. Levinson (Eds.), *Rethinking Linguistic Relativity*. Cambridge: Cambridge University Press.
- Halliday, M., & Hasan, R. (1967). *Cohesion in English*. London: Longman.
- Hawkins, B. W. (1993). On universality and variability in the semantics of spatial adpositions. In C. Zelinsky-Wibbelt (Ed.), *The Semantics of Prepositions: from mental processing to natural language processing* (pp. 327-349). Berlin: Mouton de Gruyter.
- Heine, B. (1997). *Cognitive Foundations of Grammar*. Oxford: Oxford University Press.
- Herskovits, A. (1988). Spatial expressions and the plasticity of meaning. In B. Rudzka-Ostyn (Ed.), *Topics in cognitive linguistics* (pp. 271-297). Amsterdam/Philadelphia: Benjamins.
- Hoey, M. (1991). *Patterns of Lexis in Text*. Oxford: Oxford University Press.
- Hoey, M. (2005). *Lexical Priming: A new theory of words and language*. London/New York: Routledge.
- Hottenroth, P.-M. (1993). Prepositions and object concepts: A contribution to cognitive semantics. In C. Zelinsky-Wibbelt (Ed.), *The Semantics of Prepositions: from mental processing to natural language processing* (pp. 179-219). Berlin: Mouton de Gruyter.
- Hunston, S. (2002). *Corpora in Applied Linguistics*. Cambridge: Cambridge University Press.
- Hunston, S., & Francis, G. (2000). *Pattern Grammar: A corpus-driven approach to the lexical grammar of English*. Amsterdam/Philadelphia: John Benjamins.
- Jackendoff, R. (1983). *Semantics and cognition*. Cambridge, MA: MIT Press.
- Jackendoff, R. (1990). *Semantic Structures*. Cambridge, MA: MIT Press.
- Jackendoff, R. S. (1997). *The Architecture of the Language Faculty*. Cambridge, MA: MIT Press.
- Jakobson, R. (2003). The metaphoric and metonymic poles. In R. Dirven & R. Pörrings (Eds.), *Metaphor and Metonymy in Comparison and Contrast* (pp. 41-47). Berlin/New York: Mouton de Gruyter.
- Johnson, M. (1987). *The Body in the Mind: The Bodily Basis of Meaning, Imagination, and Reason*. Chicago/London: The University of Chicago Press.
- Kay, P., & McDaniel, C. (1978). The linguistic Significance of the Meaning of Basic Color Terms. *Language*, 54(3), 610-646.
- Kennedy, G. (1991). *Between and through: The company they keep and the functions they serve*. In *English corpus linguistics : studies in honour of Jan Svartvik* (pp. 95-110). London: Longman.
- Kita, S. (2006). A grammar of space in Japanese. In S. C. Levinson & D. P. Wilkins (Eds.), *Grammars of Space: Explorations in Cognitive Diversity* (pp. 437-474). Cambridge: Cambridge University Press.
- Kleiner, F. (2005). Book review of Andrea Tyler and Vyvyan Evans, 2003. The Semantics of English Prepositions *Journal of Pragmatics*, 37, 775-779.

- Kolstad, V. T. (1991). *Understanding of containment in 5.5-month-old infants*. Unpublished manuscript, Seattle, WA.
- Kövecses, Z. (2000). The scope of metaphor. In A. Barcelona (Ed.), *Metaphor and Metonymy at the Crossroads: A Cognitive Perspective* (pp. 79-92). Berlin: Mouton de Gruyter.
- Kövecses, Z. (2002). *Metaphor: A Practical Introduction*. Oxford: Oxford University Press.
- Kövecses, Z., & Radden, G. (1998). Metonymy: Developing a cognitive linguistics view. *Cognitive Linguistics*, 9(1), 37-77.
- Krashen, S. D. (1981). *Second Language Acquisition and Second Language Learning* Oxford: Oxford University Press.
- Kreitzer, A. (1997). Multiple levels of schematization: a study in the conceptualization of space. *Cognitive Linguistics*, 8(4), 291-325.
- Lakoff, G. (1987). *Women, fire, and dangerous things: What categories reveal about the mind*. Chicago: University of Chicago Press.
- Lakoff, G. (2007). How language structures space. In V. Evans, B. Bergen & J. Zinken (Eds.), *The Cognitive Linguistics Reader* (pp. 130-167). London/Oakville: Equinox Publishing Ltd.
- Lakoff, G., & Johnson, M. (1980). *Metaphors We Live By*. Chicago: University of Chicago Press.
- Lakoff, G., & Johnson, M. (1999). *Philosophy in the Flesh: the embodied mind and its challenge to Western thought*. New York: Basic Books.
- Landau, B. (1996). Multiple geometric representations of objects in languages and language learners. In P. Bloom, M. Peterson, L. Nadal & M. Garrett (Eds.), *Language and Space* (pp. 317-363). Cambridge, MA: MIT Press.
- Langacker, R. W. (1987). *Foundations of Cognitive Grammar, i, Theoretical Prerequisites*. Stanford: Stanford University Press.
- Langacker, R. W. (1989). Absolute Construal. In F. J. Heyvaert, F. Steurs & F. G. Droste (Eds.), *Worlds behind words : essays in honour of Prof Dr F G Droste on the occasion of his sixtieth birthday* (pp. 65-75). Leuven: Leuven University Press.
- Langacker, R. W. (1997). The contextual basis of cognitive semantics. In J. Nuyts & E. Pedersen (Eds.), *Language and Conceptualization* (pp. 229-252). Cambridge: Cambridge University Press.
- Langacker, R. W. (2008). *Cognitive Grammar: A basic introduction*. Oxford: Oxford University Press.
- Lee, D. (2001). *Cognitive Linguistics An Introduction*. Oxford, New York: Oxford University Press.
- Leech, G. N. (1969). *Towards a semantic description of English*. Harlow: Longmans.
- Leech, G. N. (1974). *Semantics*. Harmondsworth: Penguin.
- Levinson, S. C., & Wilkins, D. P. (Eds.). (2006). *Grammar of Space: explorations of cognitive diversity*. Cambridge, New York Cambridge University Press.
- Levinson, S. C., & Willkins, D. P. (2006). The background to the study of the language of the space. In S. C. Levinson & D. P. Wilkins (Eds.), *Grammars of Space: Explorations in Cognitive Diversity* (pp. 1-23). Cambridge: Cambridge University Press.
- Lindkvist, K. G. (1976). *A comprehensive study of conceptions of locality in which English prepositions occur*. Stockholm: Almqvist & Wiskell International.
- Lindner, S. (1983). *A lexico-semantic Analysis of English Verb-Particle Constructions*. Bloomington: Indiana University Linguistic Club.

- Lindstromberg, S. (1998). *English Prepositions Explained*. Amsterdam: John Benjamins.
- Littlemore, J. (2009). *Applying Cognitive Linguistics to Second Language Learning and Teaching* Basingstoke: Palgrave Macmillan.
- Littlemore, J., & Low, G. D. (2006). *Figurative Thinking and Foreign Language Learning*. Basingstoke: Palgrave Macmillan.
- Mandler, J. (1992). How to build a baby: II. Conceptual primitives. *Psychological Review*, 99, 587-604.
- Matsumoto, Y. (2003). *Ninchi Imiron [Cognitive Semantics]*. Tokyo: Taishukan Shoten.
- McBee, M. (2009). Spilt Wine. Retrieved 17 January, 2010, from http://fiction.eserver.org/short/spilt_wine.html
- Melčuk, I. (1988). Semantic description of lexical item in an Explanatory Combinatorial Dictionary: basic principles and heuristic criteria. *International Journal of Lexicography*, 1(3), 165-188.
- Merleau-Ponty, M. (1962). *Phenomenology of perception*. London: Routledge & Kegan Paul.
- Momiyama, Y., & Fukada, S. (2003). Imi no kakuchou [extension of meaning]. In Y. Ikegami, S. Kawakami & M. Yamanashi (Eds.), *Ninchi Imiron*. Tokyo: Taishukan shoten.
- Murphy, R. (2004). *English Grammar in Use: A self-study reference and practice book for intermediate students of English*. Cambridge: Cambridge University Press.
- Nattinger, J. R., & DeCarrico, J. S. (1992). *Lexical Phrases and Language Teaching*. Oxford: Oxford University Press.
- Nesselhauf, N. (2005). *Collocations in a Learner Corpus*. Amsterdam/Philadelphia: John Benjamins.
- Partington, A. (1998). *Patterns and Meanings*. Amsterdam/Philadelphia: John Benjamins.
- Pawley, A., & Syder, F. H. (1983). Two puzzles for linguistic theory: nativelike selection and nativelike fluency. In J. C. Richards & R. W. Schmidt (Eds.), *Language and Communication* (pp. 191-227). London: Longman.
- Peters, A. M. (1983). *The Units of Language Acquisition*. Cambridge: Cambridge University Press.
- Pound, E. (1931). *How to read*. London: Desmond Harmsworth.
- Pulman, S. G. (1983). *Word Meaning and Belief* London: Croom Helm.
- Quirk, R., Greenbaum, S., Leech, S., & Svartvik, J. (1985). *A Comprehensive Grammar of the English Language*. New York: Longman.
- Radden, D. (1985). Spatial metaphors underlying prepositions of causality. In W. Paprotte & R. Dirven (Eds.), *The Ubiquity of Metaphor* (pp. 177-207). Amsterdam: John Benjamins.
- Reddy, M. J. (1979). The conduit metaphor: A case of frame conflict in our language about language. In A. Ortony (Ed.), *Metaphor and Thought*. Cambridge: Cambridge University Press.
- Rice, S. (1996). Prepositional prototype. In M. Putz & R. Dirven (Eds.), *The construal of space in language and thought* (pp. 135-165). Berlin/New York: Mouton de Gruyter.
- Rice, S., Sandra, D., & Vanrespaille, M. (1999). Prepositional Semantics and the Fragile Link Between Space and Time. In M. Hiraga, C. Sinha & S. Wilcox (Eds.), *Cultural, Psychological & Typological Issues in Cognitive Linguistics*. Amsterdam: John Benjamins.
- Rohlfing, K. J. (2001). No preposition required. The role of prepositions for the understanding of spatial relations in language acquisition. In M. Pütz, S. Niemeier & R. Dirven (Eds.),

- Applied cognitive linguistics. 1, Theory and language acquisition* (pp. 229-247). Berlin, New York: Mouton de Gruyter.
- Rosch, E. (1973). On the internal structure of perceptual and semantic categories. In T. E. Moore (Ed.), *Cognitive Development and the Acquisition of Language* (pp. 111-144). New York: Academic Press.
- Rosch, E. (1975). Cognitive representations of semantic categories. *Journal of Experimental Psychology: General*, 104, 192-233.
- Rosch, E. (1978). Principles of categorization. In E. Rosch & B. Lloyd (Eds.), *Cognition and categorization* (pp. 27-48). New York: Hillsdale.
- Rosch, E. (1999). Reclaiming concepts. *Journal of Consciousness Studies*, 6, 61-77.
- Sandra, D., & Rice, S. (1995). Network analyses of prepositional meaning: mirroring whose mind - the linguist's or the language user's? *Cognitive Linguistics*, 6(1), 89-130.
- Schönefeld, D. (2006). From conceptualization to linguistic expression: Where languages diversify. In S. T. Gries & A. Stefanowitsch (Eds.), *Corpora in Cognitive Linguistics: Corpus-based Approaches to Syntax and Lexis*. Berlin/New York: Mouton de Gruyter.
- Shortall, T. (2007). *Cognition, corpus, curriculum*. Unpublished PhD thesis, University of Birmingham.
- Sinclair, J., & Clari, M. (Eds.). (2003). *Collins COBUILD Advanced Learner's English Dictionary*. Glasgow: HarperCollins Publishers.
- Sinclair, J., & Moon, R. (2002). *Collins COBUILD Dictionary of Phrasal Verbs*. Glasgow: HarperCollins.
- Sinclair, J. M. (1991a). *Corpus Concordance Collocation*. Oxford: Oxford University Press.
- Sinclair, J. M. (2003). *Reading Concordances*. Harlow: Pearson Education Limited.
- Sinclair, J. M. (1991b). Shared knowledge. In J. E. Alatis (Ed.), *Linguistics and language pedagogy : the state of the art* (pp. 489-496). Washington D.C.: Georgetown University Press.
- Sinclair, J. M. (2004). *Trust the Text: language, corpus and discourse*. New York: Routledge.
- Stubbs, M. (1993). British Tradition in Text Analysis: From Firth to Sinclair. In M. Baker, G. Francis & E. Tognini-Bonelli (Eds.), *Text and Technology in Honour of John Sinclair* Philadelphia/Amsterdam: John Benjamins.
- Stubbs, M. (1996). *Text and Corpus Analysis: Computer-assisted Studies of Language and Culture*. Oxford: Blackwell Publishers.
- Stubbs, M. (2002). *Words and Phrases: Corpus Studies of Lexical Semantics*. Malden/Oxford/Victoria: Blackwell Publishing.
- Takao, T. (2003). Metaphor hyogen no imi to gainenka. In Y. Ikegami, S. Kawakami & M. Yamanashi (Eds.), *Ninchi Imiron*. Tokyo: Taishukan shoten.
- Talmy, L. (1988). The relation of grammar to cognition. In B. Rudzka-Ostyn (Ed.), *Topics in Cognitive Linguistics* (pp. 165-205). Amsterdam: John Benjamins.
- Talmy, L. (2000). *Toward a cognitive semantics. Vol. 2, Typology and process in concept structuring* Cambridge, Mass., London: MIT Press.
- Talmy, L. (2007). How language structures space. In V. Evans, B. Bergen & J. Zinken (Eds.), *The Cognitive Linguistics Reader* (pp. 766-830). London: Equinox Publishing Ltd.
- Taylor, J. R. (1988). Contrasting Prepositional Categories: English and Italian. In B. Rudzka-Ostyn (Ed.), *Topics in Cognitive Linguistics* (pp. 299-326). Amsterdam: John Benjamins.

- Taylor, J. R. (2002). *Cognitive Grammar*. Oxford, New York: Oxford University Press.
- Taylor, J. R. (2003). *Linguistic Categorization* (3rd ed.). Oxford: Oxford University Press.
- Taylor, J. R. (2008). Prototype in Cognitive Linguistics. In P. Robinson & N. C. Ellis (Eds.), *Handbook of Cognitive Linguistics and Second Language Acquisition* (pp. 39-65). New York/London: Routledge.
- Teubert, W. (2010). *Meaning, Discourse and Society*. Cambridge: Cambridge University Press.
- Thomas, H., Heath, D., Roe, I. F., & Götz, D. (Eds.). (2004). *A Valency Dictionary of English: A Corpus-Based Analysis of the Complementation Patterns of English Verbs, Nouns and Adjectives*. Berlin: Mouton de Gruyter.
- Traugott, E. (1985). 'Conventional' and 'dead' metaphors revisited. In W. Paprotte & R. Dirven (Eds.), *The Ubiquity of Metaphor* (pp. 17-56). Amsterdam: John Benjamins.
- Tsuji, Y. (Ed.). (2003). *Ninchi Gengogaku eno Shotai [Introduction to Cognitive Linguistics]*. Tokyo: Taishukan.
- Tyler, A. (2006). Response to Filipovic Kleiners (2005) review of Tyler & Evans (2003) The semantics of English Prepositions. *Journal of Pragmatics*, 38(6), 971-974.
- Tyler, A., & Evans, V. (2003b). The case of *over*. In B. Nerlich, Z. Todd, V. Herman & D. Clarke (Eds.), *Polysemy: Flexible Patterns of Meaning in Mind and Language* (pp. 99-159). Berlin, New York: Mouton de Gruyter.
- Tyler, A., & Evans, V. (2001). Reconsidering prepositional polysemy networks: the case of *over*. *Language*, 77(4), 724-765.
- Tyler, A., & Evans, V. (2003a). *The semantics of English Prepositions: Spatial Scenes, Embodied Meaning and Cognition*. Cambridge: Cambridge University Press.
- Ungerer, F., & Schmid, H.-J. (2006). *An Introduction to Cognitive Linguistics* (2nd ed.). Harlow: Pearson Education Limited.
- Vandeloise, C. (1991). *Spatial prepositions: a case study from French*. Chicago: The University of Chicago Press
- Vandeloise, C. (1994). Methodology and analyses of the preposition *in*. *Cognitive Linguistics*, 5, 157-184.
- Vandeloise, C. (2003). Containment, support, and linguistic relativity. In H. Cuyckens, R. Dirven & J. Taylor (Eds.), *Cognitive Approaches to Lexical Semantics I* (pp. 393-425). Berlin: Mouton de Gruyter.
- Verela, F. J., Thompson, E., & Rosch, E. (1993). *The Embodied Mind*. Cambridge, MA/London: The MIT Press.
- Wittgenstein, L. (1953). *Philosophical Investigation* (G. E. M. Anscombe, Trans. 2nd ed.). Oxford: Blackwell.
- Wray, A. (1999). Formulaic language in learners and native speakers. *Language Teaching*, 32, 213-231.
- Wray, A. (2002). *Formulaic Language and the Lexicon*. Cambridge: Cambridge University Press.
- Yu, N. (1999). Spatial Conceptualization of Time in Chinese. In M. K. Hiraga, C. Sinha & S. Wilcox (Eds.), *Cultural, psychological and typological issues in cognitive linguistics* (pp. 69-84). Amsterdam/Philadelphia: John Benjamins.
- Zadeh, L. (1965). Fuzzy Sets. *Information and Control*, 8(3), 338-353.
- Zlatev, J. (2003). Situated embodiment: Studies in emergence of spatial meaning. In H. Cuyckens, R. Dirven & J. Taylor (Eds.), *Cognitive approaches to lexical semantics* (pp. 447-494). Berlin: Mouton de Gruyter.