

**DEVELOPMENT AND APPLICATION OF TIME-TEMPERATURE
INTEGRATORS TO THERMAL FOOD PROCESSING**

GARY STEPHEN TUCKER

**Department of Food Manufacturing Technologies
Campden & Chorleywood Food Research Association
Chipping Campden, Glos., GL55 6LD**

**A thesis submitted to the University of Birmingham
for the degree of DOCTOR IN PHILOSOPHY**

**School of Chemical Engineering
The University of Birmingham
April 2008**

UNIVERSITY OF
BIRMINGHAM

University of Birmingham Research Archive

e-theses repository

This unpublished thesis/dissertation is copyright of the author and/or third parties. The intellectual property rights of the author or third parties in respect of this work are as defined by The Copyright Designs and Patents Act 1988 or as modified by any successor legislation.

Any use made of information contained in this thesis/dissertation must be in accordance with that legislation and must be properly acknowledged. Further distribution or reproduction in any format is prohibited without the permission of the copyright holder.

ABSTRACT

This thesis describes the research and development into a range of time-temperature integrators (TTIs) for the measurement of process values for food heat treatments. The TTIs are based on the first order thermal degradation of bacterial α -amylases. Two new TTIs are described, one for mild pasteurisation treatments of a few minutes at 70°C and one for full sterilisation of >3 minutes at 121.1°C. Examples are given of how these TTIs are applied to a variety of industrial thermal processes. These include traditional methods such as canning, but also more complex systems such as tubular heat exchangers and batch vessels, together with novel systems such as ohmic heating. Some of the industrial experiments dealt with processes in which the thermal effects had not been previously quantified.

For sterilisation, a highly innovative solution is required. A candidate TTI material is identified based on an amylase secreted by the hyperthermophilic microorganism *Pyrococcus furiosus*. This microorganism exists in extreme conditions where it metabolises in boiling volcanic pools; with elemental sulphur readily available, in water of high salinity, and in a reducing atmosphere. The amylase it secretes is naturally thermostable and withstands a full thermal sterilisation process.

ACKNOWLEDGEMENTS

The thesis work was part of a DEFRA LINK project to develop and apply time-temperature integrators (TTIs) to measure the safety of thermal processes, in particular those with flowing foods. AFM 194 project (01 Jul 2003 to 31 Mar 2007) involved CCFRA, University of Birmingham, Marlow Foods, HJ Heinz Co. Ltd, Greencore, Daniels Chilled Foods Ltd, Kerry Aptunion (UK) Fruit Preparations, Masterfoods, Deans Foods, Giusti Ltd, Unilever Research Colworth and Baxters of Speyside Ltd. Funding from DEFRA is gratefully acknowledged.

I would like to thank my supervisor Professor Peter Fryer for his guidance in helping me write this thesis. I know I provided him with some entertainment during his long haul flights to Australia as he read through the first drafts. I believe subsequent drafts were more consistent in style and message! Thanks also to my CCFRA supervisor Dr. Mike Stringer.

Thanks also go to individuals who helped with specific parts of the work. Alek Lach and Jim Butt (Kerry Aptunion) who willingly provided facilities at the Okehampton factory in which all of the Chapter 4 TTI work was carried out. The advances in applying TTIs would not have happened so effectively without the collaborative efforts of the factory staff. Emma Hanby and Marise Cronje (CCFRA) for experimental work on the BAA70 TTIs. Professor Mike Adams (University of Georgia, USA) for providing the first materials for the sterilisation TTI. Johnston Pickles (Baxters of Speyside) and Steve Tearle (Masterfoods) for generating data and supplying photographs for the non-isothermal TTI calibrations in Chapter 5. And finally to Ingrid Schaffers (Unilever Vlaardingen) for providing material from fermentation batches of yeast cells encoded with the gene for producing thermostable amylase.

Special thanks go to Gary Mycock and Stuart Warren (Unilever Vlaardingen) for their moral support and guidance in developing TTI methods for applying to industrial processes. We shared many TTI experiences together and the discussions often resulted in improvements to the methods used. The endorsement of TTIs by Unilever gave me considerable encouragement.

Finally, to my colleagues at CCFRA who have had to put up with me telling them how wonderful these TTIs are. I hope my enthusiasm has rubbed off on some of them.

NOMENCLATURE AND ABBREVIATIONS

A_{final}	final (enzyme) activity after a specific time-temperature history, minutes ⁻¹
A_{initial}	initial (enzyme) amylase activity, minutes ⁻¹
BAA	amylase from <i>Bacillus amyloliquefaciens</i>
BLA	amylase from <i>Bacillus licheniformis</i>
Bi	Biot number, which is a dimensionless group that compares the heat transfer rates resulting from external heat transfer and internal heat conduction
C_p	material specific heat capacity, J.kg ⁻¹ .K ⁻¹
C_0	colour reading at 600 nm for an unheated control sample of FDP after 0-minutes incubation at 92°C
C_{05}	colour reading at 600 nm for an unheated control sample of FDP after 5-minutes incubation at 92°C
C_{t5}	colour reading at 600 nm for a heated sample of FDP after 5-minutes incubation at 92°C
D_T	decimal reduction time of amylase or microorganisms at a fixed temperature (T), minutes
f_h	heating factor, defined as the temperature response parameter derived from the logarithmic heating curve (IFTPS, 1997), minutes
F	sterilisation value for microorganism destruction, minutes
F_0	sterilisation value specifically for destruction of <i>C. bot.</i> spores, minutes
FDP	freeze-dried powder comprising proteins extracted from a <i>Pyrococcus furiosus</i> fermentation
h_{fp}	fluid to particle heat transfer coefficient, W.m ⁻² .K ⁻¹
IT	initial particle centre temperature, °C
j	lag factor, defined as a measure of the thermal lag before the can centre temperature responds to the changing environment temperature (IFTPS, 1997), dimensionless
k	proportionality constant for 1 st order kinetics, s ⁻¹
k	thermal conductivity of a food or silicone particle, W.m ⁻¹ .K ⁻¹
L	infinite slab thickness, m
n	number of terms for series convergence of the analytical solution to conduction heat transfer in an infinite slab
N_{final}	final number of microorganisms after a specific time-temperature history
N_{initial}	initial number of microorganisms

N_0	initial (time zero) number of microorganisms per unit mass or volume
N	final number of microorganisms per unit mass or volume after heating
R_T	retort or constant environment temperature, °C
P	pasteurisation value, minutes
t	process time, seconds or minutes
T	particle centre temperature, also used as the test temperature °C
$T(t)$	variable product temperature, which is a function of time (t), °C
T_{ref}	reference temperature used to calculate the D_T value, °C
TTI	time-temperature integrator
x	distance from the surface of the infinite slab or the characteristic particle dimension, m
X_0	initial amylase activity, s^{-1}
X	final amylase activity, s^{-1}
z	kinetic factor, which is the temperature change required to effect a ten-fold change in the D_T value, °C

Greek symbols

α	material thermal diffusivity, $m^2 \cdot s^{-1}$
ε	temperature offset from the correct test temperature, °C
ρ	material density, $kg \cdot m^{-3}$
Δt	time interval used for time-temperature measurements, minutes

CONTENTS

CHAPTER 1: INTRODUCTION TO THERMAL PROCESSING AND TO TIME-TEMPERATURE INTEGRATORS	1
Executive Summary	1
1.1 Thermal Processing of Foods	2
1.1.1 Thermal sterilisation processes	5
1.1.2 Thermal pasteurisation processes	8
1.1.3 Commercial sterilisation	9
1.2 Thermal process validation	12
1.3 Time-Temperature Integrators (TTIs)	14
1.3.1 Previous TTI work	19
1.4 Amylase solutions for TTIs used in this thesis	20
1.8 Content of subsequent thesis chapters	22
CHAPTER 2: ENGINEERING PROPERTIES OF TTI PARTICLES FOR P-VALUE MEASUREMENTS IN FOOD PROCESSES	24
2.1 Calculation of process values with TTIs	25
2.2 Preparation of silicone TTI tubes	28
2.3 Preparation of TTI particles	29
2.4 Calculating dimensions of TTI particles	31
2.4.1 Mathematical equations for heating factors, used for estimating TTI particle size	33
2.5 Preparation of amylase solutions for use in TTI particles	39
2.5.1 <i>Bacillus amyloliquefaciens</i> α -amylase at 85°C (BAA85)	40
2.5.2 <i>Bacillus licheniformis</i> α -amylase at 90°C (BLA90) or 93.3°C (BLA93)	40
2.6 Procedures for conducting the amylase assays	40
2.7 Measurement and calculation of amylase D-values	42
2.7.1 Adjustment of D-values for offset in calibration bath temperature	46
2.8 Measurement and accuracy of P-values using TTI tubes	47
2.8.1 Discussion on TTI accuracy	52
2.9 Selection of TTI storage conditions	57
2.10 Methods of applying TTIs to food processes	59

2.11 Conclusions	60
CHAPTER 3: EVALUATION OF A TIME-TEMPERATURE INTEGRATOR FOR MILD PASTEURISATION PROCESSES	62
3.1 Introduction to Mild Heat Treatments	63
3.2 Potential TTI systems	64
3.3 Measurement of D- and z-Values for BAA70	66
3.3.1 Preparation of the solutions for amylase analysis	67
3.3.2 Kinetic evaluations of BAA70	68
3.3.3 Results for D_{70} -value and z-value	69
3.4 Spectrophotometer or colorimeter methods for the amylase assays	74
3.5 Influence of different storage conditions on TTI stability	78
3.5.1 Experiment 1: The effect of storing sets of TTI tubes in water for 56 days and testing for amylase activity every 14 days	81
3.5.2 Experiment 2: The effect of storing TTI tubes for up to 14 days before use, testing for initial (unheated) activity on days 0, 3, 8, 11, and 14	82
3.5.3 Experiment 3: The effect of storing TTI tubes for up to 14 days after processing, testing for final (heated) activity on days 0, 3, 7, and 14	84
3.6 Industrial Evaluation of the BAA70 TTI	85
3.6.1 Pasteurisation of the headspace of a hot-filled soup carton	85
3.6.2 Top-up pasteurisation requirements after filling of a high acid sauce in plastic pots	88
3.6.3 Headspace pasteurisation in mini jam jars	91
3.6.4 Pasteurisation in baked mushroom quiches	94
3.7 Conclusions from mild pasteurisation BAA70 TTI trials	95
CHAPTER 4: CASE STUDIES OF TTI APPLICATIONS TO FOOD PROCESSES	97
4.1 Calculation of P-values with TTIs	98
4.1.1 Microbiological process targets	99
4.2 Experimental TTI trials on fruit products	100
4.2.1 Description of the types of processes	103
4.2.2 Introducing TTI particles into batch mixing vessels	103

4.2.3 Ensuring streamline flow of TTI particles in continuous heating systems	106
4.2.4 Recovery of TTI particles from the processes, tanks or bags	107
4.3 Application of TTIs to fruit products processed in stirred vessels	112
4.3.1 Case Study 1: 400 kg batch of diced strawberries processed in a 1,000 kg stirred vessel	112
4.3.2 Case study 2: 500 and 430 kg batches of pineapple & passion fruit processed in a 1,000 kg stirred vessel	117
4.3.3 Case Study 3: 325 kg batch of apricot processed in a 1,000 kg stirred vessel	119
4.4 Application of TTIs to fruit products processed through a tubular heat exchangers	121
4.4.1 Case Study 4: 1,000 kg batch of pear & toffee processed in a 22 mm diameter tubular heat exchanger	122
4.5 Application of TTIs to fruit products processed in a commercial ohmic heater	125
4.5.1 Case Study 5: 250 kg batch of whole strawberries processed in a 75 kW ohmic column	127
4.5.2 Case Study 6: 850 kg batch of blackcurrants and 790 kg of diced pineapple processed in a 75 kW ohmic column.	131
4.5.3 Case Study 7: 400 kg batch of diced strawberries processed in a 75 kW ohmic column	138
4.5.4 Case Study 8: Two 850 kg batches of nectarine & orange processed in a 75 kW ohmic column, hot-filled into 8.5 kg plastic bags	145
4.6 Discussion of results and findings from the industrial trials	152
4.6.1 Future needs	153
CHAPTER 5: A STERILISATION TIME-TEMPERATURE INTEGRATOR BASED ON AMYLASE FROM THE HYPERTHERMOPHILIC MICROORGANISM <i>PYROCOCCUS FURIOSUS</i>	154
5.1 Introduction	154
5.1.1 <i>Pyrococcus furiosus</i>	160
5.1.2 <i>Pyrococcus woesei</i>	162
5.1.3 Methods for the measurement of amylase activity	164
5.1.4 Objectives	165
5.2 Production of <i>Pyrococcus furiosus</i> amylase	166
5.2.1 <i>Pyrococcus furiosus</i> growth medium	168

5.2.2 Encapsulation of Freeze-Dried-Powder into TTI tubes	171
5.3 Development of the discontinuous assay methods	172
5.3.1 Radox assay	172
5.3.2 Starch assay	173
5.3.3 Calculation of amylase activity rates	174
5.4 Determination of D- and z-values for the FDP using isothermal measurements	175
5.4.1 Optimising the isothermal D-value methods to conserve FDP	178
5.5 Non-isothermal calibration	181
5.5.1 Measurement of amylase activity rates	188
5.5.2 F-value, $D_{121.1}$ and z calculation procedures	192
5.6 Conclusions and further work	199
5.6.1 Further work	201
CHAPTER 6: FUTURE TTI PROJECTS	203
6.1 Review of literature on gene expression	204
6.1.1 Food industry acceptability	209
6.2 Evaluation of the Unilever yeast amylase	210
6.2.1 Tubular heat exchanger TTI trial	212
6.2.1 Decreasing the heat stability of the Unilever yeast amylase	214
6.3 Further work	217
CHAPTER 7: OVERALL CONCLUSIONS	220
REFERENCES	227
APPENDIX 1: Preparation of <i>Pyrococcus Furiosus</i> Broths Supplied by University of Georgia	243

CHAPTER 1: INTRODUCTION TO THERMAL PROCESSING AND TO TIME-TEMPERATURE INTEGRATORS

‘Imagination is more important than knowledge’

Albert Einstein, Physicist

Executive Summary

This thesis describes the research and development of a range of time-temperature integrators (TTIs) that are used to measure process values for thermally processed foods. Process values are either for pasteurisation heat treatments (generally $< 100^{\circ}\text{C}$) or sterilisation (> 3 minutes at 121.1°C). All of the TTIs described in this thesis are based on the first order thermal degradation of the protein α -amylase.

Traditional methods for the estimation of microbiological kill levels in thermal processes use temperature sensors followed by a calculation procedure that converts the time and temperature measurements to a process value. This value is related to the key information, which is the log reduction in microorganism numbers attributed to the process, through the use of simple first order models for microorganism death. However, it is not always possible to use temperature sensors for food measurements. TTIs are one of the alternative measurement tools that are required for foods in which a temperature sensor interferes with the food product, its package or the processing system. Applications for TTIs are therefore to measure process values in a variety of complex food processes in which temperature sensors are not appropriate.

Several types of TTIs are described for measuring a range of pasteurisation processes; one of the TTIs is a new TTI. An improved TTI encapsulation system is described that enhances methods for applying TTIs to industrial measurements. The new TTI is for measuring mild pasteurisation treatments of the order of only a few minutes at 70°C . These mild pasteurisation treatments are commonly used for chilled foods with shelf lives less than 10-

days. Many of the mild pasteurisation treatments take place in heated vessels or continuous ovens in which the movement of the food product prevents the use of temperature sensors. Many examples are given in which this new TTI enables these processes to be (i) quantified and (ii) optimised.

For sterilisation processes, the challenges are much greater because of the limited number of enzyme systems designed to operate above 100°C and at pressures greater than 1 bar. A candidate TTI material is identified based on an amylase secreted by a hyperthermophilic microorganism. This organism, *Pyrococcus furiosus*, exists in extreme conditions where it has evolved in boiling volcanic pools; with elemental sulphur readily available, in water of high salinity, and in a reducing atmosphere. The amylase it secretes is naturally thermostable and is found to withstand a full thermal sterilisation time-temperature process. Data within this thesis shows the potential of *Pyrococcus furiosus* amylase as a sterilisation TTI.

Examples are given for how the new and existing TTIs can be applied to a variety of industrial thermal food processes. These include traditional methods such as canning, and also more complex systems such as tubular heat exchangers and batch vessels, together with novel systems such as ohmic heating. Process values are calculated using the difference in amylase activity before and after processing. Colorimetric and spectrophometric methods are used to measure the residual amylase activities and their relative merits are compared as assay methods. The calculation procedures for converting these activities to process values assume the first order kinetics for the amylase degradation by heat, as with microorganism death.

Some of the industrial experiments deal with processes in which the thermal effects havenot been quantified previously. Considerable over-processing is typical in these situations and so the application of TTIs to these food processes results in improvements in the line efficiency and on occasion in the food quality.

1.1 Thermal Processing of Foods

The application of high temperatures, referred to as thermal processing, is the most commonly used method to kill or control the numbers of microorganisms present within high moisture foods and on packaging material surfaces. Thermal processing is a general term that describes

all forms of heat treatments in which microorganism numbers are controlled by heat. This includes heat processed container types such as metal cans, plastic trays, pouches, glass jars and even cartons. Canning was the original mode of heat treatment and the terms canning and thermal processing are often used for the same purpose.

An interesting history of canning and thermal processing is given by Westler Foods (http://www.westlerfoods.com/pdf/canning_process.pdf). The canning process dates back to the late 18th century in France when Emperor Napoleon Bonaparte, concerned about keeping his armies fed, offered a cash prize to whoever could develop a reliable method of food preservation. Nicholas Appert discovered that the application of heat to food in sealed glass bottles preserved the food from deterioration. In about 1806, Appert's principles were successfully trialled by the French Navy on a wide range of foods including meat, vegetables, fruit and even milk. More than 50 years later, Louis Pasteur provided the explanation for the effectiveness of canning when he demonstrated that the growth of microorganisms was the cause of food spoilage.

An Englishman, Peter Durand, took the process one step further and developed a method of sealing food into unbreakable tin containers. This was perfected by Bryan Dorkin and John Hall, who set up the first commercial canning factory in England in 1813. Tin containers had the advantage over glass bottles of being lighter, easier to seal and less prone to breakage during transportation and storage. The original food can was made of iron and was coated with a fine layer of tin to stop it from rusting. There is little difference in the external appearance of the original tin cans to the stainless steel cans of today. It has been stated that metal cans have not needed to evolve too much since the 1800s because the original design was so good (Pickles, 2006); it was one of the few examples of a design that was almost perfect from conception.

It was discovered that if the food was heated at high temperatures and under pressure, the required heating and cooling times became significantly shorter. The first pressure retort was built in 1851, which allowed steam temperatures greater than 100°C to be used, with the benefit of reduced thermal process times which improved the flavour, texture and nutritional value of the food. The first automated production lines were introduced in 1897 and produced around 6 cans an hour, which compares with today's production lines that produce in excess of 1,500 cans a minute.

After the 1920s, canned food lost its military image and became fully accepted as part of the national diet. In the UK, the Campden Experimental Factory was opened in 1919 as part of the University of Bristol. Its remit was to understand the canning process in greater depth so that canned foods could be manufactured to higher quality and with a greater assurance of food safety (Gillespy, 1951). Thermal processing is still a key part of (the now) Campden & Chorleywood Food Research Association.

Food canning is a long established and well-understood technique, which has served consumers well for nearly 200 years. It produces shelf stable products that can be stored at ambient temperatures. The basic principles of canning have not changed dramatically since Nicholas Appert and Peter Durand developed the process. Heat, at levels sufficient to destroy microorganisms, is applied to foods packed into sealed or airtight containers. The amount of time needed for processing is different for each food, depending on the presence of antimicrobial hurdles (e.g. acidity, preservatives) and the ability to transfer heat to the food thermal centre.

The canning process was developed to preserve food safely and for the integrity of the sealed cans to last for long periods of time. Manufacture of thermally processed foods is closely monitored using a system called Hazard Analysis and Critical Control Point, or HACCP (Bauman, 1974). This is a system that identifies areas of potential contamination within the food process and builds checkpoints, or critical control points (CCPs), to ensure that the product safety is maintained at all times. Validation of a thermal process and the determination of CCP levels is a challenging exercise that requires a variety of accurate tools. TTIs are one of the tools that can be used to validate the thermal process by measurement of integrated process values.

Manufacture of a thermally processed food can be broken down into two basic operations:

- (a) The food is heated to reduce the numbers of microorganisms to an acceptably small statistical probability of pathogenic and spoilage organisms capable of growth under the intended storage conditions (DoH, 1994), and,
- (b) The food is sealed within an hermetic package to prevent re-infection.

Preservation methods, such as traditional canning, seal the food in its package before the application of heat to the packaged food product, whereas in operations such as aseptic filling, cook-chill and cook-freeze, the food is heated prior to dispensing into its pack. Either method reduces the numbers of microorganisms to commercially accepted levels (DoH, 1994), which includes both pathogenic and spoilage microorganisms.

There are millions of types of microorganism that can spoil food products, with just a few that can cause damage to our health from the by-products of their metabolism. Several types of bacteria need consideration when designing a food packaging and processing line. Of primary concern from a public health perspective are those that produce toxins such as *Clostridium botulinum*, *Listeria monocytogenes*, *Salmonella*, *Escherichia coli*, *Staphylococcus aureus*, *Bacillus cereus* and *Campylobacter* (Stumbo, 1965). These can be controlled by the use of sterilising solutions and/or heat, with the aim to achieve the condition of commercial sterility for the packaged food.

1.1.1 Thermal sterilisation processes

A thermal sterilisation process is required if no preservation hurdle to microbial growth exist in the food product; for example high acidity or preservatives. For low-acid foods the most heat-resistant pathogen that might survive the thermal process is *C. botulinum* (Esty and Meyer, 1922). This bacterium can form heat-resistant spores under adverse conditions, which will germinate in the absence of oxygen and produce a highly potent toxin that causes a potentially lethal condition known as botulism. This can cause death within seven days. UK practice is for a commercial sterilisation process to reduce the probability of a single *C. botulinum* spore surviving in a pack of low-acid product to one in one million million (i.e. 1 in 10^{12}). This is called a ‘botulinum cook’, and the standard process is to achieve at least 3 minutes equivalent at 121.1°C, referred to as $F_0 3$ (DoH, 1994).

C. botulinum spores only germinate in anaerobic conditions where there is available moisture as well as nutrients, and the acidity levels are low (pH > 4.5). Thus, food products with pH over 4.5 are often referred to as “low acid” foods whereas products with pH of 4.5 and below are referred to as “high acid” foods. In the USA, the critical limit between high and low acid foods is taken at pH 4.6 (<http://vm.cfsan.fda.gov/~comm/lacf-toc.html>). This critical pH limit

is an important determinant as to whether heat-preserved foods receive a pasteurisation or sterilisation treatment. Pasteurisation often requires foods to be acidified prior to thermal treatment (e.g. pickled vegetables). It is also important to ensure that spoilage organisms in a high acid food do not cause a shift in pH to the low acid level and thereby allow the potential outgrowth of *C. botulinum* spores. Sterilisation processes are typically operated in the range 115 to 135°C whereas pasteurisation processes are typically 75-115°C.

In fact, the origin of the $F_0 3$ process relates to thermal death kinetic work carried out by a number of researchers between approximately 1921 and 1950. The original death kinetics work often quoted is that of Esty and Meyer (1922), who investigated the death kinetics of *Bacillus botulinus* (then name for *C. botulinum*). The most prominent of their data was that published for the maximum heat resistance, referred to as the terminal death time, for *B. botulinus* grown under optimum conditions. They started with an initial population of 60 billion spores and thermally processed until a negative result was obtained, i.e. all the spores were destroyed. Results of maximum resistance to moist heat for the most resistant strain were reported as follows:

4	minutes at 120°C	(248°F)
10	minutes at 115°C	(239°F)
33	minutes at 110°C	(230°F)
100	minutes at 105°C	(221°F)
330	minutes at 100°C	(212°F)

In the original paper, the above data were simply plotted as shown in Figure 1.1 but the data can be converted to a logarithmic terminal time axis giving the now more conventional approach shown in Figure 1.2 (Townsend et al., 1938). Stumbo (1949) took information from the Esty and Meyer (1922) work for the ideal thermal death time data, and used 1,804 spore suspensions in his work. These data were summarised as an F value of 2.78 minutes; which was the time taken to destroy 60 billion spores at 250°F (121.1°C). This is now the more likely basis of the $F_0 3$ value used widely today.

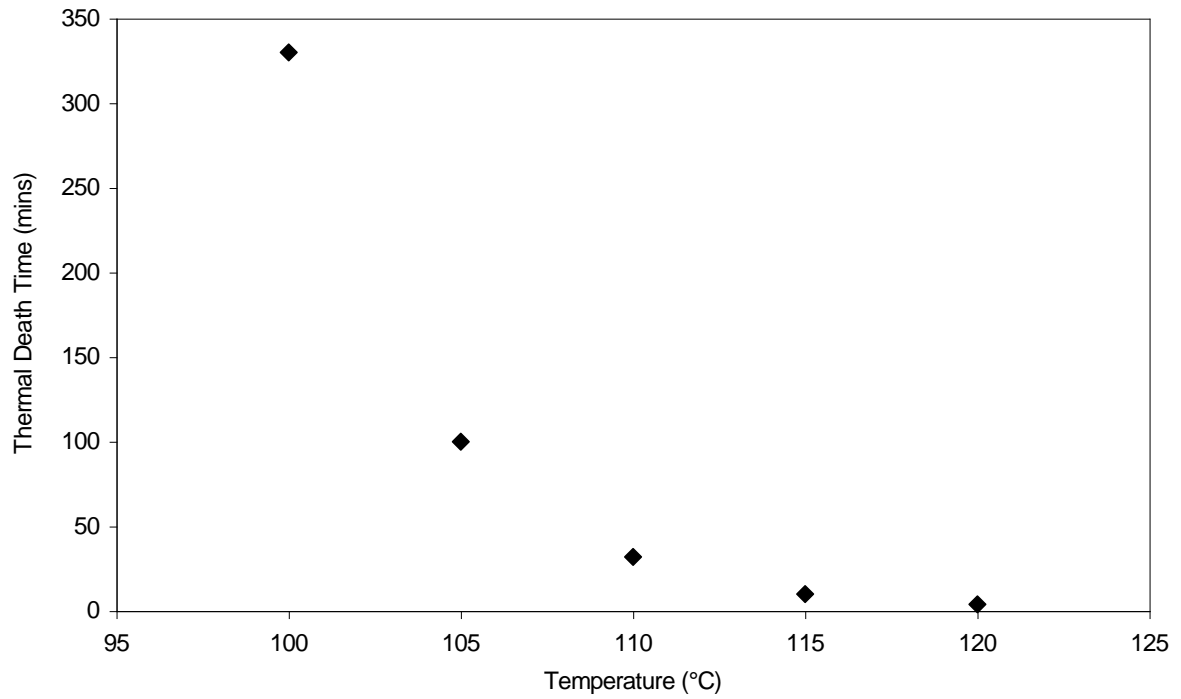

Figure 1.1: Maximum heat resistance data for *C. botulinum*, taken from Esty and Meyer (1922). 60 billion spores in a phosphate buffer solution, pH 7.0.

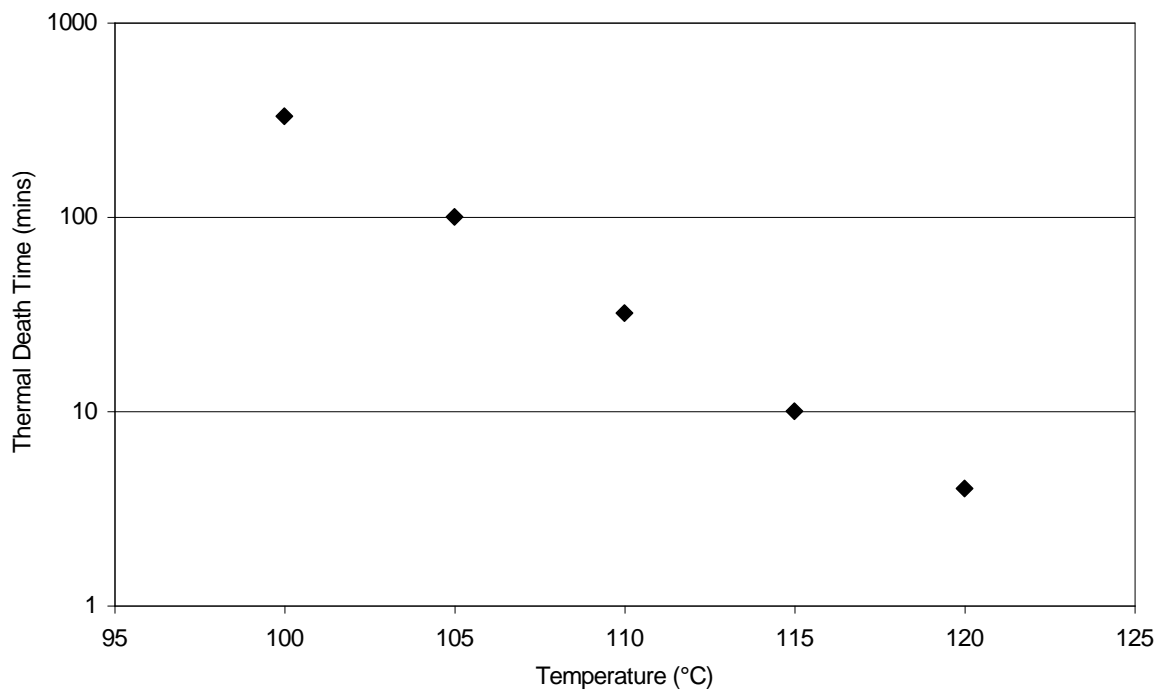

Figure 1.2: Maximum heat resistance data for *C. botulinum*, taken from Esty and Meyer (1922). 60 billion spores in a phosphate buffer solution, pH 7.0. Data plotted with thermal death time on a logarithmic axis.

1.1.2 Thermal pasteurisation processes

All thermal processes target the spores of *C. botulinum* if no other effective hurdle to its growth is present. These are referred to as sterilisation processes. Ideally, *C. botulinum* will grow best in anaerobic conditions such that high oxygen concentrations have the effect of reducing or even stopping its growth (Day, 2001). There is now a growing trend to apply additional hurdles to microbial growth that allow the food processor to use milder heat treatments referred to as pasteurisation; and obtain heat preserved foods of high quality.

For example, growth of most strains of *C. botulinum* are inhibited at refrigeration temperatures, although there are psychrotrophic strains that can grow at low temperatures and are relevant for extended life chilled foods. This is of critical concern with sous-vide and vacuum packed foods that only receive a mild heat treatment and rely heavily on precise control of chill temperatures to prevent out-growth (CCFRA, 1992b). The BLA90 TTI (*Bacillus licheniformis* amylase), described in later chapters of this thesis, was used to measure thermal processes where psychrotrophic strains of *C. botulinum* must be destroyed. A process equivalent to 10 minutes at 90°C is designed to achieve at least 6-log reductions in numbers of *C. botulinum* spores (CCFRA, 1992 and 1992b). Many UK pasteurisation treatments are designed for a 6-log kill; for example, if the initial loading of psychrotrophic *C. botulinum* spores is 10²/g then a 6-log process will reduce this to 10⁻⁴/g. This is a very small number of surviving spores, which is best described as a probability of a spore surviving the process rather than an absolute number.

Other microorganisms are relevant for foods where hurdle technology is used to reduce the thermal impact of a process. *Listeria* species are an aerobic group of bacteria that can survive and grow at low temperatures, but are fortunately killed by mild temperature-time treatments. The process used to achieve a 6-log reduction in *Listeria monocytogenes* is 70°C for 2 minutes, and this is also applicable to *Salmonella* and *E. coli* species (CCFRA, 1992). However, the log reductions achieved from a 70/2 process with these latter two organisms is substantially higher than six because of their lower heat resistance than *Listeria*. This group of bacteria are referred to as aerobic pathogens and exist only as vegetative cells. The BAA70 TTI, described in Chapter 3 of this thesis, was developed to measure thermal processes for which the aerobic pathogen group must be destroyed.

Pasteurisation is nowadays used extensively in the production of many different types of food, such as fruit products, pickled vegetables, jams and ready meals (CCFRA, 1992). Food may be pasteurised in a sealed container, analogous to a canned food, or pasteurised in a continuous process, analogous to an aseptic filling operation. It is important to note that pasteurised foods are not sterile and must rely on other preservation hurdles to ensure their microbiological stability for the desired length of time.

1.1.3 Commercial sterilisation

Although pasteurisation or sterilisation of the food is the desired condition, the food for either treatment is referred to as commercially sterile. By definition, commercial sterility (or appertization) of food is ‘the condition achieved by the application of heat which renders food free from viable micro-organisms, including those of known public health significance, capable of growing in the food at temperatures at which the food is likely to be held during distribution and storage’ (DoH, 1994). In practice, however, the food manufacturer makes a decision on the level of commercial risk with the applied thermal process because it is not possible to kill all of the micro-organisms and produce a saleable product. A pasteurisation process usually operates to 6 log reductions of the target organism (CCFRA, 1992), and this differs from fully sterilised foods where the intention is to achieve at least 12 log reductions in *C. botulinum* spores. The lower target log reductions for pasteurisation are because of the reduced risks associated with the target microbial species when compared with the lethal botulinum toxin, and also because of the presence of additional preservation hurdles.

The severity of a thermal process is calculated as an integrated F-value or P-value (Ball and Olsen, 1957), using heat resistance data on the likely pathogenic or spoilage organisms present. Death of bacteria by moist heat is assumed to be almost logarithmic (Stumbo, 1965), i.e. it follows first order reaction kinetics in which the rate of decomposition is directly proportional to the concentration. Equation 1.1 describes the rate of change in concentration (or numbers N) of microorganisms with time (t), for a first order reaction where (k) is the proportionality constant:

$$-\frac{dN}{dt} = kN \quad 1.1$$

or,

$$-\frac{dN}{N} = k \cdot dt \quad 1.2$$

Integrating Equation 1.2 between the limits of N_0 at time zero and N after a time of heating (t), results in Equation 1.3. N_0 is the initial (time zero) number of microorganisms per unit mass or volume, and N the final number after heating for t minutes.

$$k = \frac{\ln(N_0/N)}{t} \quad 1.3$$

This is usually expressed using base ten logarithms (\log_{10}), which are referred to in the remaining text without the subscript (\log). Hence, Equation 1.3 becomes:

$$k = \frac{2.303 \log(N_0/N)}{t} \quad 1.4$$

The conventional microbiological approach to quantifying thermal processing uses the decimal reduction time (D_T), which is defined as the time required to destroy 90% of the organisms by heating at a single reference temperature (T_{ref}). This is calculated by the time required to traverse one log cycle on a microorganism survivor curve, as shown in Figure 1.3.

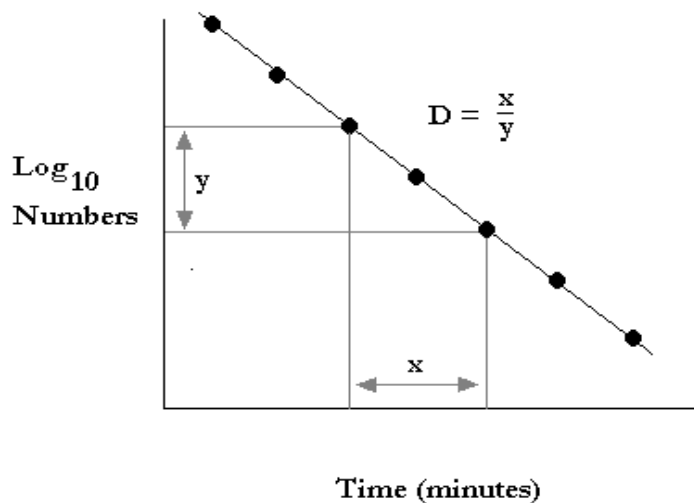

Figure 1.3: Logarithmic survivor curve showing the calculation of decimal reduction time (D_T), the time required to decrease the number of organisms by a factor of ten.

Substituting terminology from microbiological death kinetics into the general equation for the straight line shown in Figure 1.3, Equation 1.5 is obtained.

$$\log N_0 - \log N = \frac{t}{D_r} \quad 1.5$$

or,

$$t = D_r \cdot \log\left(\frac{N_0}{N}\right) \quad 1.6$$

By comparing Equations 1.4 and 1.6, the decimal reduction time and proportionality factor can be equated. Decimal reduction time is the more convenient term used in thermal processing, as given in Equation 1.7.

$$D_r = \frac{2.303}{k} \quad 1.7$$

Equation 1.6 presents the heating time (t) needed at a constant reference temperature in order to reduce the number of microorganisms from their initial population (N_0) to a final population (N). This heating time is also referred to as a sterilisation or F-value, and represents the target number of minutes at temperature (T) to achieve the desired log reduction in microorganisms (see Equation 1.8).

$$F = D_r \cdot \log\left(\frac{N_0}{N}\right) \quad 1.8$$

Thus, for a sterilisation process where 12-log reductions are required, the target F-value for an organism with D-value of 0.3 minutes at 121.1°C is 3.6 minutes (Gillespy, 1951). The conventional approach in the UK (DoH, 1994) uses a D-value of 0.21 minutes at 121.1°C for *C. botulinum* spores, which equates to a minimum F-value of 2.52 minutes. This value is rounded up to F_0 3.

1.2 Thermal process validation

The objective of a process validation study is to prove that the target F-value, as calculated by Equation 1.8, is achieved under the conditions used. Conditions for the validation study should be chosen to represent those that result in the lowest levels of microbiological kill, so that under normal production conditions it is not possible for the process to be less severe.

As the number of food products and their variety increases, food companies are faced with the challenge of proving that all products are safely thermally processed. Temperature probes offer the most economical method of validating process severity, they also provide the greatest flexibility in how the data can be used. Process validation can however sometimes be difficult if temperature probes cannot be used in the processes, and so other approaches need to be adopted.

The main process categories that introduce these complexities to process validation include:

- Products cooked in continuous ovens or fryers, such as poultry joints, chicken nuggets, burgers, bread (Tucker et al., 2005).
- Products with discrete pieces cooked in steam-jacketed agitated batch vessels, such as ready meals, soups, cook-in-sauces, fruit preparations (Tucker et al., 2002; Mehauden et al., 2007)
- Particle products processed in continuous tubular and scraped surface heat exchangers, such as cook-in-sauces, preserves or dressings (Tucker et al., 2002)

If temperature probes cannot be used, a number of approaches to validating microbiological process safety are available. To prove that the thermal process has achieved the target process value or F-value during manufacture, it is necessary to conduct validation studies using an approved method. Various methods can be selected from the list below, and their choice depends on factors such as the costs, the expertise of those applying the methods, the nature of the food, and the process type.

- Microbiological methods can be used whereby cells or spores of a non-pathogenic organism, with similar temperature-induced death kinetics to the target pathogen, are embedded into an alginate bead (Brown et al., 1984). The beads are made to mimic the food pieces in their thermal and physical behaviour and so pass through the process with the food. By adding macerated food into the calcium alginate gel, a close approximation to the physical and thermal properties of the food is obtained. Typically, 30-60 spore beads will be added to a continuous heat exchanger process in order to obtain a distribution of process values. Enumeration of the surviving organisms allows the log reduction and process values to be calculated.
- Simulated trials are carried out in a pilot plant or laboratory where the heat transfer conditions of the process are replicated (CCFRA, 1977; Bee and Park, 1978). This used to be a common approach for continuous canning systems, such as hydrostatic retorts and reel & spiral cooker-coolers. These cooker-cooler systems involve the cans entering a pre-sterilisation zone on a conveyor, then travelling into the steam sterilisation zone in which the thermal treatment occurs, before finally exiting from the cooling zone. The introduction of self-contained temperature loggers that can travel with the cans has reduced the need for retort simulators. However, there are still some concerns over interference with the temperature measurements that a stainless steel logger must introduce. This is particularly true with the reel and spiral type of cooker-coolers that rely on frictional forces to induce can rotation. Changes to can density or to the centre of gravity might influence the rotational forces.
- No validation is attempted, with the process safety being inferred from temperature probing of the bulk product or the environment. Substantial over-processing is allowed, in order that the thermal process delivered to the product thermal centre is sufficient. End product testing for microbiological activity is usual. This approach is typical with the chilled foods industry, for example, with sauces cooked in steam pans and hot filled into plastic ready meal trays (CCFRA, 1992).
- Process models can be developed that predict, for example, the temperature-time history of the critical food particles as they travel through the heating, holding and cooling zones of the process (Heppell, 1985; McKenna & Tucker, 1991). This

approach is used with continuous heat exchangers, primarily to ensure that small food particles receive an adequate process. For larger particles (greater than 2-3 mm) it is usual that the spore bead method described above is employed (Brown et al., 1984).

- Biochemical time-temperature integrators (TTIs) can be applied to gather similar process data to that from microbiological methods. This method originated with work by Hendrickx et al. (1995) in which various types of bacterial amylases were found to show kinetic properties appropriate for estimating microbiological reductions. The advantage of the amylase TTIs over many biological systems is that reaction rates for amylase degradation by heat are first order, as with microbiological breakdown, and the temperature sensitivity of the reaction rates is similar to that for spore destruction.

This thesis focuses on the amylase TTI method.

1.3 Time-temperature integrators (TTIs)

A TTI system can be a biological, chemical or physical change that breaks down during heating in a reproducible manner. Enzymes such as amylase or peroxidase are suitable for TTIs because their structure breakdown is affected by both time and temperature. Typically, with enzymes, breakdown involves the helical structure unwinding as cross-links between molecular chains are broken. Many enzyme systems can regenerate after heating, however, an enzyme suitable for use as a TTI must exhibit a permanent denaturation.

The kinetics of the temperature-induced denaturation should match those of the death kinetics of the target microorganism. Specifically, the decimal reduction time (D_T) and the kinetic factor (z) are the kinetic parameters used. The kinetic factor (z -value) is a measure of how the D -value changes with temperature, and is also calculated using a semi-logarithmic approach (Stumbo, 1965). Logarithm of the D -values is plotted against temperature, and the temperature change to effect a one-log change in D -value is defined as the z -value. Most bacterial spores show z -values close to 10°C .

As described above, thermal processes are designed to reduce microbiological populations by large numbers of log reductions, typically between six and twelve (as shown in Equation 1.8).

It is unlikely that a TTI system will possess sufficient measurement sensitivity for such high log reductions in the measured parameter, whether it is a colour change or enzyme activity. Therefore, the decimal reduction time for the TTI should ideally be several times as large as that for the target microbial species, otherwise there will be insufficient colour or activity left to measure from the processed TTI. As mentioned previously, the other requirement is for the z-value to be close to that for the target microbial species.

Table 1.1 presents examples of data for microorganism death kinetics, which highlights the relatively low D_T values when compared with 'chemical' systems suitable for use as TTIs (Tables extracted from Holdsworth, 1992). Tables 1.2, 1.3 and 1.4 illustrate the wide range of D_T and z-values with vitamin, enzyme and pigment systems respectively. Each of these systems is potentially suitable for use as a TTI.

Many of the chemical systems in Tables 1.2 to 1.4 could be used as a TTI system. However, if the TTI system is intended for estimating process values and converting these to log reductions of microorganisms in foods, it is essential that the z-value of TTI and microorganism are similar. In addition, the D_T -value should be sufficiently high that changes in the measured property during a thermal process are within the measurement range of highest accuracy. This limits the choice of chemical marker, and for these reasons, the TTI systems used and developed in this thesis work were based on α -amylases. These represent a significant advance in the validation methods available for thermal processing because it can be seen clearly that very few of the chemical systems in Tables 1.2 to 1.4 show combinations of D- and z-value suitable for use in estimating microorganism reductions.

Table 1.1: Kinetic factors for microbial destruction by wet heat. Data was selected specifically for microorganisms relevant to full sterilisation processes (data from Holdsworth, 1992). All reference temperatures are 121.1°C.

Organism	Temperature (°C)	D_{121.1} (s)	z (°C)
<i>Bacillus stearothermophilus</i> (Phosphate buffer)	100-140	149	14.3
	100-140	170	12.3
	100-140	226	11.7
<i>Bacillus subtilis</i> (Phosphate buffer)	127-144	28.8	9.4
<i>Clostridium botulinum</i> (Phosphate buffer) (Water) (Pureed peas) (Meat and vegetables) (Sea food) (Poultry) (Rock lobster)	140-127	8.0	9.0
	140-127	3.1	8.5
	104-127	5.3	8.3
	100-113	6.6	9.8
	100-113	3.0	7.4
	100-113	3.0	7.4
	105-115.5	18.0	10.8
<i>Clostridium thermosaccharolyticum</i> (neutral buffer) (Aqueous)	99-127	51	14.7
	115.5-127	4,080	11.5
<i>Clostridium nigrificans</i> (baby food) (baby food)	121-131	1,550	6.7
	121-131	3,260	9.5
<i>Clostridium sporogenes</i> (Phosphate buffer) (Strained pea)	100-120	15.0	9.1
	115.5-143.3	60	9.8

Table 1.2: Kinetic factors for vitamin destruction (data from Holdsworth, 1992).

Reference temperatures vary depending on the data reported.

Heat Sensitive Vitamin	Temperature (°C)	D_T (s)	z (°C)
Vitamin A (beta carotene)			
(beef liver)	103-127	D ₁₂₂ = 2,400	23.0
(carrot juice)	104-132	D ₁₀₄ = 23,600	25.5
Vitamin B1 (thiamin)			
(buffer)	109-150	D ₁₀₉ = 9,500	24.0
(carrots)	109-150	D ₁₅₀ = 830	22.0
(spinach)	109-150	D ₁₅₀ = 610	22.0
(pea puree)	121.1	D _{121.1} = 10,000	31.3
(lamb puree)	109-150	D ₁₂₂ = 710	25.0
(pork luncheon meat)	100-127	D ₁₂₇ = 6,300	35.0
Vitamin B6 (pyridoxine)			
(cauliflower)	106-138	D ₁₂₁ = 24,000	43.0
Pantothenic acid			
(beef puree pH 5.4)	118-143	D _{121.1} = 138,000	35.8
(beef puree pH 7.0)	118-143	D _{121.1} = 135,000	19.3
Folic Acid			
(apple juice)	100-140	D ₁₄₀ = 100,000	31.0
Vitamin C (ascorbic acid)			
(peas)	110-132	D _{121.1} = 50,000	18.0
(spinach)	70-100	D ₁₀₀ = 25,900	74.4

Table 1.3: Kinetic factors for enzyme destruction (data from Holdsworth, 1992). Much of these data were taken by the frozen foods industry for the purposes of estimating enzyme breakdown during blanching, hence the lower reference temperatures.

Heat Sensitive Vitamin	Temperature (°C)	D_T (s)	z (°C)
Peroxidase (horseradish)	60-160	D ₁₂₀ = 830	27.8
(potato puree)	100-140	D ₁₂₀ = 70	35.0
Catalase (spinach)	60	D ₆₀ = 60	8.3
Lipoxygenase (pea/soya)	50-80	D ₇₇ = 720	3.4
Pectinesterase (guava syrup pH 4.0)	74-95	D ₉₆ = 35	16.5
Polyphenol oxidase (potato)	80-110	D ₈₉ = 100	7.8

Table 1.4: Kinetic factors for pigment destruction by wet heat. Reference temperatures vary depending on the data reported. (data from Holdsworth, 1992)

Heat Sensitive Pigment	Temperature (°C)	D_T (s)	z (°C)
Green (chlorophylls)			
(green beans)	80-148	D _{121.1} = 1,260	38.8
(peas)	80-148	D _{121.1} = 1,500	39.4
Red			
(raspberry juice)	78-108	D ₁₀₈ = 7,000	30.4
(grapes)	76.7-121	D ₁₂₁ = 7,600	54.7
Browning Reactions			
(chestnut paste darkening)	105-128	D _{121.1} = 141,000	24.6
(milk, hydromethyl furfural formation)	105-160	D ₁₃₀ = 12	26.7

1.3.1 Previous TTI work

Use of amylase TTIs as an alternative means of process validation, to either temperature or indirect microbial systems, has received considerable attention in recent years (such as in Hendrickx et al., 1992; De Cordt et al., 1994; Maesmans et al., 1994; Hendrickx et al., 1995; Van Loey et al., 1996; Van Loey et al., 1997a; Tucker, 1999; Tucker, 2000; Tucker et al., 2002). Reasons for the interest lay with the unique properties that bacterial amylases would appear to exhibit, most importantly that they are one of the very few chemical systems that can be characterised with a z-value close to that for microorganism destruction.

Typically a spore-forming microorganism will exhibit z-values in the range 9-11°C, with vegetative cells showing slightly lower values in the range 6-8°C (CCFRA, 1992). Table 1.1 presents examples of various spore-forming microorganisms that are important to the sterilised food sector. Values for microorganisms critical to pasteurised foods show similar ranges for spores and vegetative cells. Amylase TTIs were chosen for use as mimics for

destruction of microorganisms because they were reported to exhibit measured z-values in the range 9-10°C (Hendrickx et al., 1992; Van Loey et al., 1996).

There are several advantages of using an amylase TTI to estimate process values compared with one of the alternative methods such as a microbiological spore techniques. For example, preparation of the TTIs and conducting the assays takes minutes not days, transportation from the laboratory to a factory requires less caution because of high decimal reduction times at ambient or chilled conditions, and unlike spores there are no issues with outgrowth.

1.4 Amylase solutions for TTIs used in this thesis

Two of the existing amylase TTI systems are described in this thesis; both were developed by Hendrickx and co-workers (Hendrickx et al., 1995; Van Loey et al., 1996 and 1997a).

Conditions for their use were not changed for data presented in this thesis, other than to develop the industrial methods for applying TTIs to measuring pasteurisation values in food processes. These TTI systems are based on commercially available amylases from *Bacillus amyloliquefaciens* (BAA) and *Bacillus licheniformis* amylase (BLA), both at 10 mg/mL amylase in a Tris buffer solution. Kinetic data for the two TTIs were measured several times over the duration of the work in this thesis.

Two new TTI systems are described in later chapters. A new amylase TTI has been developed for mild heat treatments where the objective was for the food to receive at least the equivalent of 2 minutes at 70°C, and this is described in Chapter 3. A novel approach for a TTI system suitable for surviving the time and temperature extremes of a full sterilisation process, which requires at least the equivalent of 3 minutes at 121.1°C, is described in Chapter 5.

With several TTI systems that cover heat treatments from a few minutes at 70°C to many minutes at 121.1°C, a nomenclature system was used to help differentiate between the TTI types. The first three letters referred to the sources of amylase, for example *Bacillus licheniformis* amylase is BLA. This is followed by numbers that refer to the reference temperature of the microorganism that this TTI was designed to mimic, for example 90°C for psychrotrophic strains of *C. botulinum*. Hence this TTI is BLA90. Table 1.5 presents the range of amylase TTIs discussed within this thesis.

Of the TTIs listed in Table 1.5, the amylase from *Bacillus licheniformis* was used for two different pasteurisation processes. The two pasteurisation treatments appropriate to this TTI were for (i) acidic foods stored in ambient conditions and (ii) for low-acid foods stored chilled for extended periods of 10-40 days (CCFRA, 1992a). These treatments targeted different microorganisms but the integrated thermal effects were within the measurement range of this amylase.

Table 1.5: Measurement range of amylase TTIs used to measure process values for pasteurisation and sterilisation processes.

TTI Code	TTI Process Description	Organism of amylase origin	Target process (minutes at T_{ref})	D-value at T_{ref} (minutes)	z-value (°C)	Range (minutes at T_{ref})
BAA70	Cook-chill	<i>Bacillus amyloliquefaciens</i>	2 minutes at 70°C	8-10	8.0-9.0	2-25
BAA85	High acid	<i>Bacillus amyloliquefaciens</i>	5 minutes at 85°C	8-10	9.0-9.5	4-30
BLA90	REPFEDS* or sous-vide	<i>Bacillus licheniformis</i>	10 minutes at 90°C	15-25	9.0-9.5	5-50
BLA93	Acid Foods	<i>Bacillus licheniformis</i>	5 or 10 minutes at 93.3°C	8-12	9.0-9.5	4-30
PFA121	Sterilisation	<i>Pyrococcus furiosus</i>	3 minutes at 121.1°C	21-24	9.0-11.0	3-40

* REPFEDS are Refrigerated Processed Food of Extended Durability

1.6 Content of subsequent thesis chapters

The following chapters describe the work required to produce a reliable amylase TTI method for validation of thermal processes delivered in complex heating systems.

Chapter 2 provides details of how the TTI systems were manufactured for use in measuring thermal process values. This includes the mathematical basis used to estimate the correct size and shape of TTI particles where an experimental trial involved pieces of food material. Also included are the methods for preparing amylase solutions and for calculations of P-value, together with an analysis of error in the calculated P-values.

Chapter 3 contains details of a new TTI referred to as BAA70. This was required to measure thermal processes of the order of a few minutes at 70°C. Also included are data from amylase assays using a colorimeter which was a portable instrument used to obtain amylase activities immediately after an industrial TTI test. Comparisons are made in this chapter between spectrophotometer and colorimeter values. Tests on different storage conditions for BAA70 are described.

Chapter 4 presents information on some of the industrial trials in which the BAA85 and BLA93 TTI systems were applied to measure P-values. Industrial applications of these TTI systems is of high importance, and to achieve this aim, an extensive testing program was embarked upon. All of the examples chosen were for processes in which temperature probes could not be used reliably. A variety of process, product and packaging types are shown in Chapter 4 so that the application range of these TTIs can be highlighted. All of this work was undertaken in one fruit processing factory.

Chapter 5 contains a description of an innovative idea for developing a TTI system suitable for use at sterilisation temperatures where several minutes at 121.1°C are required. The idea was to identify a microorganism that produced a thermostable amylase which needed to be an order of magnitude higher than any commercially available amylases. The hope/theory was that there might be an organism that thrives in thermally hostile environments yet has a metabolic need to produce amylase. Several such organisms were identified from a literature search and research carried out on one, *Pyrococcus furiosus*, that seemed to be the most promising. Data presented in Chapter 5 showed that this approach had considerable merit.

Chapter 5 is the main part of this thesis in that it contains genuinely new research that has immense industrial application.

The final chapter (6) presents some views on what might lie ahead for TTI research projects in the future. In particular, the approaches for obtaining thermostable amylase for use in the sterilisation TTI might be best achieved by expressing the amylase-producing gene from *Pyrococcus furiosus* into a microorganism that is easy to culture, such as a yeast cell. Some early results are presented on this approach, which indicate considerable promise.

CHAPTER 2: CONSTRUCTION OF TTI PARTICLES FOR P-VALUE MEASUREMENTS IN FOOD PROCESSES

‘Real knowledge is to know the extent of one’s ignorance’

Confucius

This chapter gives guidance on how to prepare and use TTIs based on α -amylase dissolved in buffer solutions. The objectives of using TTIs are to obtain data for the measurement of P-values in real food processes. This requires the TTI solutions to be enclosed in miniature containers that prevent the amylase from contacting the food otherwise the first order kinetics could be compromised. Several methods have been explored, starting from trapping a bubble in a silicone compound that was later injected with amylase solution (Tucker, 1999), but the most successful is based on a silicone tube. The latter method is described in this chapter.

Information is also given on how the dimensions of the silicone particles were estimated in order that the thermal and physical properties were suitable for use as mimics of actual food particles. This procedure utilised the analytical solutions for conduction heat transfer into common geometric shapes and compared these solutions with those obtained experimentally from heated particles. This method was developed for the canning industry by Ball (1923, 1927) and was modified here for application to food particles.

Application of a TTI particle for measurement of P-values in industrial food processes requires a number of properties of the TTI system:

- The chosen measurement system, in this case amylase, must show kinetics of breakdown by heat that are similar to those of the target microbial species. For pasteurisation processes these range from a few minutes at 70°C to many minutes at 93.3°C.
- The encapsulation system must ensure the amylase is contained securely. No leakage of the amylase solution can occur, either of amylase leaking out into the food or any

components of the food leaking into the amylase. It should be a simple task to extract an exact aliquot of amylase solution from the TTI particle for purposes of conducting the assay. This is done using a 25 μ L hypodermic syringe.

- Physical and thermal properties of a TTI particle should be close to those of the target food particles. Many of the industrial processes where TTIs are used for P-value measurement require the TTIs to flow with the food. If the TTI particles behave differently to the food then there will be doubts concerning the validity of the P-values measured from TTIs.
- All components of the amylase solutions and the materials for constructing the particles should be non-toxic (food compatible materials) and should not cause damage to the processing equipment.
- TTI particles should be clearly identifiable in the food, to assist recovering of the TTIs. It is important that all TTIs introduced to the food are recovered; for the purposes of analysing the TTIs but also to avoid a TTI particle entering the food chain.

This chapter will deal with the above issues, and present the solutions that were arrived at to make them suitable for application to industrial food processes.

2.1 Calculation of process values with TTIs

Enzymes, or more specifically amylase breakdown by heat, shows first order reaction kinetics for certain concentrations of amylase in pH-controlled buffer solutions (Hendrickx et al., 1995). This is highlighted in the example in Figure 2.1; which is for an amylase from *Bacillus amyloliquefaciens*, showing a D-value of 10.1 minutes at 85°C. Analysis of residual amylase concentration at each heating time used spectrophotometric techniques to calculate the amylase activities. These tests are known as assays.

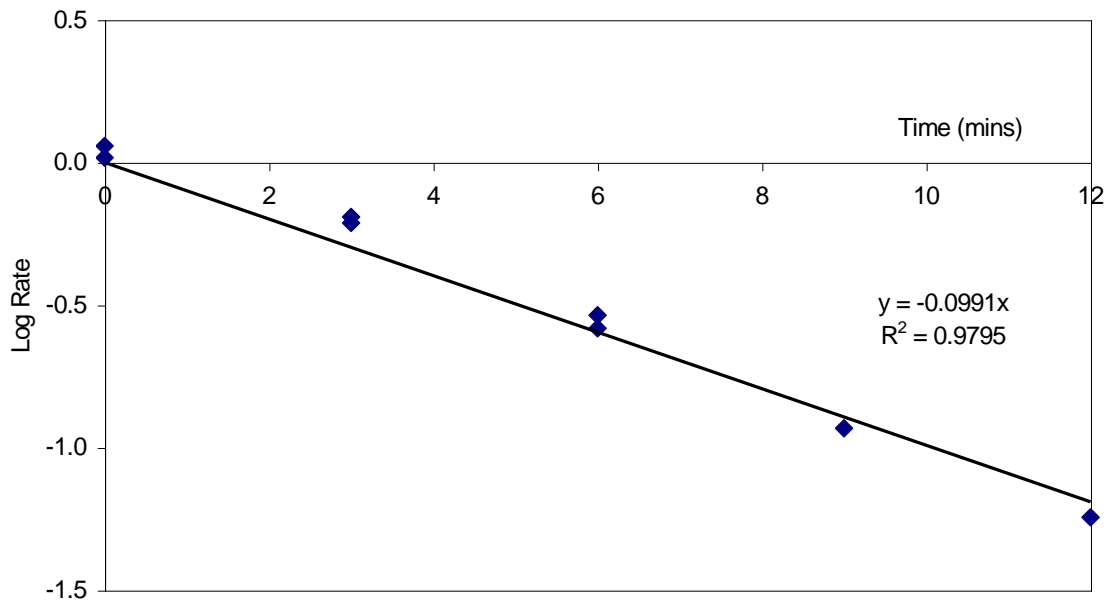

Figure 2.1: Example of a first order reaction curve for an amylase from *Bacillus amyloliquefaciens*, showing D-value of 10.1 minutes at 85°C.

Process values or F-values estimated with TTIs are calculated from the initial and final amylase activities. Instead of using the initial and final number of surviving microorganisms, as in Equation 1.8, the F-value equation uses amylase activities before and after heat treatment. This is shown in Equation 2.1. Activity can be measured as a rate of colour development when amylase is reacted with a commercially available amylase reagent (such as that from Randox Laboratories Ltd). This is a relatively simple chemical test to perform, and is described in more detail in section 2.6.

$$F = D_T \cdot \log\left(\frac{A_{initial}}{A_{final}}\right) \quad 2.1$$

where, A_{final} is the final amylase activity after a specific time-temperature history, minutes^{-1}
 $A_{initial}$ is the initial amylase activity, minutes^{-1}
 D_T is the amylase decimal reduction time at a fixed temperature (T), minutes

Equation 2.1 demonstrates how to calculate a sterilisation (F-value) or pasteurisation (P-value) based on measurements of enzyme activity. Most amylase TTIs used for validating industrial processes (Tucker et al., 2002) have been for the pasteurisation regime and so P-values are appropriate. Chapter 4, however, presents a novel approach for obtaining an amylase suitable for sterilisation processes, but apart from this, all other processes measured with TTIs are for pasteurisation.

Decimal reduction time (D_T value) is used with the calculation of P-value from amylase activity measurements (see Equation 2.1), because this equation estimates log reductions in activity, or in other words, the number of decimal reductions. However, if a P-value is calculated from temperature measurements, the z-value is used in the calculation (Bigelow et al., 1920). In order that an amylase TTI system can be applied to estimate microbiological log reductions, it is essential that the z-value for microbiological destruction and for amylase structure breakdown are similar. Equation 2.2 presents the lethal rate equation used to calculate a P-value, which integrates the time and temperature effect of a thermal process, as measured from a temperature probe.

$$P = \int_0^t 10^{\frac{T(t)-T_{ref}}{z}} \cdot dt \quad 2.2$$

P-values are specific to a z-value and reference temperature, and can be written with the z-value as a super-script and T_{ref} as a sub-script. However, for most of the descriptions in this thesis the P-value is used in its generic form. In Equation 2.2, the reference temperature is shown as T_{ref} , which must be the same as that used in calculating the D_T -value. For simplicity, the sub-script for the D_T -value is shown as T and not T_{ref} . $T(t)$ is the measured food product temperature that changes with time (t). Equations 2.1 and 2.2 should provide the same measured P-value or F-value providing that the D_T -value is quoted at the reference temperature (T_{ref}) and the z-value is appropriate to the amylase TTI system. A combination of Equations 2.1 and 2.2 results in Equation 2.3.

$$P = \int_0^t 10^{\frac{T(t)-T_{ref}}{z}} \cdot dt = D_T \cdot \log\left(\frac{A_{initial}}{A_{final}}\right) \quad 2.3$$

where, $T(t)$ is the product temperature, which is a function of time, °C

T_{ref} is the reference temperature for the D_T value, °C

t is the process time, minutes

z , the kinetic factor, is the temperature change required to effect a ten-fold change in the D_T value, °C

2.2 Preparation of silicone TTI tubes

The first step when constructing a TTI particle was to seal a few microlitres of amylase solution into a tube. Silicone tubing was found to be effective as a means of enclosing the amylase solutions and preventing contact with the food materials. Methods of preparing the silicone tubes are described together with how they can be moulded into geometries that represent food particles.

Lengths of Altesil high strength silicone tubing (Altec, Alton, UK), of 2.0 mm bore 0.5 mm wall, or of 2.5 mm bore 0.5 mm wall, were cut into approximately 10 mm lengths. Figure 2.2 illustrates examples of silicone tubes before and after they are moulded into different shaped particles. Two types of silicone elastomer were used; Sylgard 170 (black) and Sylgard 184 (transparent), both purchased from VWR International Ltd. Sylgard 170 had the advantage that it cured rapidly at 40°C and the black ended TTI tubes showed up easily in foods. Its disadvantage when used to simulate particles in flowing food experiments was its high density of 1,400 kg.m⁻³ (Dow Corning, 1998) relative to water-based foods. This compared with a density of 1,050 kg.m⁻³ for Sylgard 184 (Dow Corning, 1986).

To create a 2-3 mm plugged end, one end of the 10 mm tube was dipped into uncured silicone elastomer. Plugged tubes were then heated in a convection oven at 70°C for 30-minutes to cure the first end plug. This treatment time was not critical because there was little damage that could be done to either the tube or plug before it was filled with amylase solution.

Once the first end plug was cured, a hypodermic syringe was used to inject the tubes with at least 20 µL of an amylase solution. The open end of a tube was then sealed by squeezing the tube until the amylase solution was forced just proud of the open tube end, and it was then dipped in liquid Sylgard (at room temperature) so, when the pressure was released, the

Sylgard was drawn into the tube. This ensured that good contact was made between the amylase and Sylgard. Any air bubbles left above the amylase solution could expand and stress the TTI tubes on heating. Filled TTI tubes were heated in a convection oven at 40°C for 30-minutes to cure the second end plug. It was important not to heat above 40°C or to extend the heating times otherwise there was a danger of both partial thermal inactivation of the amylase, or of drying out the TTI tube.

When sealed, the TTI tubes were stable and could be stored immersed in buffer solutions in the fridge for up to 21 days or in the freezer for up to 6 months, possibly longer. Reduction in initial amylase activity dictated the length of storage time. Typically, it was found that a loss in initial activity of up to 50% could be tolerated without affecting the calculated P-value. Chapter 3 presents further information on storage conditions for the TTIs used to measure mild pasteurisation treatments; however it was considered good practice to apply these storage conditions to all of the TTI types.

2.3 Preparation of TTI particles

For some applications with food particles, it was necessary to make the TTI tubes into a similar shape and size to the food particles. This ensured that the measured P-value from the TTI particle was similar to that at the core of the food particle. These are referred to as TTI particles. Making the TTI particles required the use of moulds, which were designed for different particle dimensions according to the procedures below.

TTI tubes were first prepared as described previously. These were placed into the moulds so that there was one TTI tube in the centre of each particle. Figure 2.2 shows an example of a mould used for making cylindrical particles of diameter 13 mm and length 25 mm. Silicone base and curing agent were mixed to a ratio of 10:1 (for transparent Sylgard 184) and poured into the moulds. Sylgard 184 rather than Sylgard 170 (black) was used for making TTI particles because it was transparent and this gave the advantage that the TTI tube was visible inside the particle. It was difficult to extract amylase solution from an opaque TTI particle.

To cure the TTI particles, the moulds were heated in a 40°C oven for 30 minutes or until the Sylgard has started its curing process (Dow Corning data sheet, 1986). These were left at

room temperature for a further 2-3 hours until the curing reactions had progressed to the stage whereby the surface tackiness was gone. Particles could then be removed from the mould once fully cured and were kept chilled under water or in buffer solution until ready for use. Larger TTI particles sometimes required an additional step in which the curing time was extended with an overnight period at room temperature.

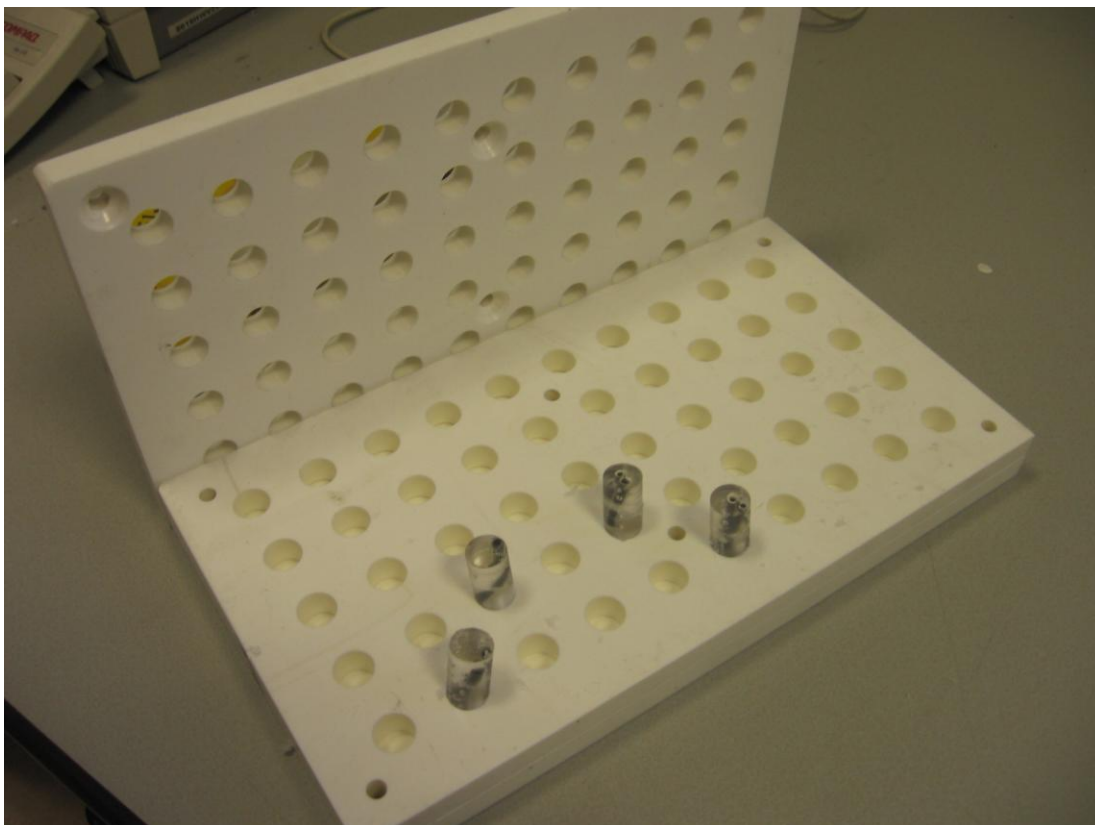

Figure 2.2: Example of TTI particle moulds for making cylindrical TTI particles of diameter 13 mm and length 25 mm.

Positioning of a TTI tube inside of a TTI particle was carefully done so that the amylase solution was at the particle centre. For the cylindrical particles shown in Figure 2.2 this required the TTI tube to be placed diagonally. Figure 2.3 shows a TTI tube inside of a spherical TTI particle. Recover of the amylase solution required the particle to be cut so that a hypodermic syringe could be inserted into the now open tube.

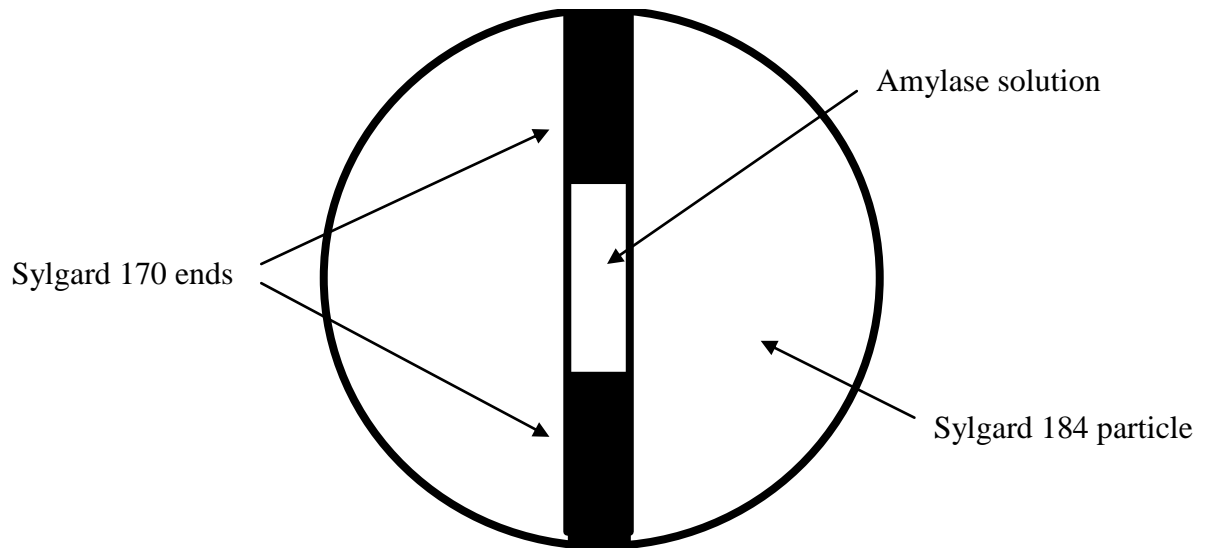

Figure 2.3: Cross sectional diagram of a spherical TTI particle showing the measuring solution at the particle centre.

2.4 Calculating dimensions of TTI particles

Food particles are solid bodies that heat by conduction in conventional processes. They are often surrounded by a liquid that heats by convection, with the rate of heat transfer from the liquid to solid dictated by the fluid-particle heat transfer coefficient (McKenna and Tucker, 1991). The relative importance of thermal conduction and of surface heat transfer can be estimated by the particle Biot number (Bi). This is a dimensionless group that compares the heat transfer rates resulting from external heat transfer and internal heat conduction, and is defined by Equation 2.4.

$$Bi = \frac{h_{fp} \cdot x}{k} \quad 2.4$$

where, k is the thermal conductivity of particle, $W \cdot m^{-1} \cdot K^{-1}$

h_{fp} is the fluid to particle heat transfer coefficient, $W \cdot m^{-2} \cdot K^{-1}$

x is the characteristic particle dimension, m

For example, if the food particle is a sphere, the characteristic dimension is the diameter, whereas for other particle types, such as cylinders or rectangular particles, it is the smallest dimension. Biot numbers less than 0.1 indicate that the fluid to particle heat transfer coefficient is the controlling process, whereas, if the calculated Biot number is greater than 10 thermal conduction is the controlling process. Biot numbers between 0.1 and 10 indicate that heat transfer is governed by both surface heat transfer and internal conduction (Krieth and Bohn, 1986). Many continuous food processes operate within this mixed region (McKenna and Tucker, 1991; Mankad, 1995).

Constructing a TTI particle that heats and cools at the same rates as a food particle requires two variables to be matched:

- Thermal diffusivity (α) – a measure of conduction within the solid. This is the critical parameter to match closely.
- Heat transfer coefficient from liquid to solid surface (h_{fp}) – a measure of the effectiveness of the liquid in transferring its heat to the surface of the solid. If the TTI particle has similar physical properties to those of the food particle then it will flow in a similar manner, and the heat transfer coefficient will be similar.

Thermal diffusivity is the variable that ‘determines the rate at which a non-uniform temperature distribution approaches equilibrium conditions’ (Wong, 1977). This is the situation that occurs in a solid food particle as it is immersed in a liquid of different temperature. Equation 2.5 presents the definition of thermal diffusivity, α , ($m^2 \cdot s^{-1}$) in terms of thermal conductivity, density and specific heat capacity.

$$\alpha = \frac{k}{\rho \cdot C_p} \quad 2.5$$

where, k is the thermal conductivity, $W \cdot m^{-1} \cdot K^{-1}$

ρ is the density, $kg \cdot m^{-3}$

C_p is the specific heat capacity, $J \cdot kg^{-1} \cdot K^{-1}$

Sylgard 184 elastomer has a thermal diffusivity of $1.02 \times 10^{-7} \text{ m}^2 \cdot \text{s}^{-1}$ (Dow Corning, 1986). This is almost 25% lower than that of a typical high water content food particle which ranges from 1.25 to $1.50 \times 10^{-7} \text{ m}^2 \cdot \text{s}^{-1}$ (Tucker and McKenna, 1991; Mankad, 1999). This means that if the silicone particles were of the same size as the high water content food particles they would heat up and cool down more slowly. The result will be lower temperatures in the TTI particles at the end of heating, which will give lower P-values than with the food particles. However, this will be compensated to a small extent by the slower rate of cooling in which the TTI particles will retain their heat for longer. Calculated P-values from TTI particles will be lower for heating but higher for cooling; with the net result almost certainly showing lower P-values.

It was therefore important to match the size and shape of the TTI particles to ensure the same P-values as the food pieces. In order to match the thermal characteristics of the food, the heating factor (f_h) of the particles was the term used to calculate 'equivalent thermal pathways'. Heating factors originated in the canning industry (Ball, 1923 and 1927) as a method for calculating process times for canned foods. By definition, it is the time taken for the difference between environment and product temperature to reduce by 90%. Heating factors are important terms in thermal process data analysis because they provide information on the rate of heating for a container of food.

The heating factor analysis also works for food particles and gives a method for comparing heating rates of different size and shape food pieces. Estimating the correct size for a TTI particle was achieved using an equation that related the heating factor (f_h) to the food thermal diffusivity (α) and its dimensions.

2.4.1 Mathematical equations for heating factors, used for estimating TTI particle size

The derivation given here is for one-dimensional heat transfer to an infinite slab geometry. It illustrates how the equations relating heating factor, thermal diffusivity and dimensional terms are obtained. The infinite slab was chosen because it is mathematically the most straightforward and illustrates the procedure. Relationships for more complex geometries requiring two and three dimensions can be calculated using a similar procedure.

Several assumptions are made when analytically solving equations for conduction heat transfer within solid bodies (Adams and Rogers, 1973). These are:

- Perfect conduction-heating solids. TTI particles and food particles will heat by conduction because they are solids. There will be a small degree of convection within the unbound liquids in a food particle but this is negligible compared to conduction.
- Instantaneous immersion into an environment at a constant temperature. This is similar to immersing a food particle into a water bath or a container of food into a raining water tunnel.
- Infinite surface heat transfer coefficient. This assumes the heating environment is well stirred if it is a water bath or there is excellent contact between the water droplets and the container surface if it is a raining water tunnel.

The bases of the mathematical comparison are the equations (i) for the analytical solutions to conduction heat transfer and (ii) from a semi-logarithmic plot of time-temperature data. The first step is to simplify the analytical solution so that the terms can be compared with the equation from the semi-logarithmic plot.

Fourier (1822) derived partial differential equations for a variety of geometrical shapes to describe how quickly the centre temperature responded to a step-change in external temperature. Mathematical solutions to these equations are readily available in textbooks (e.g. Adams and Rogers, 1973). Here, only the relevant equation for the infinite slab is used in which heat penetration occurs in one dimension only, in this case through the height dimension, with the length and width being much greater and thus irrelevant to heat transfer. The terminology in Equation 2.6 was adapted for thermal processing to make comparisons with equations from the semi-logarithmic plot of time-temperature data (Ball and Olson, 1957).

For the infinite slab, Equation 2.6 relating temperatures and time was extracted from Adams and Rogers (1973).

$$\frac{RT - T}{RT - IT} = \frac{4}{\pi} \sum_{n=1}^{\infty} \frac{1}{n} \left[\sin(n\pi x/L) \cdot e^{-\alpha(n\pi/L)^2 t} \right] \quad 2.6$$

where, RT is the retort or constant environment temperature, °C

T is the particle temperature, °C

IT is the initial particle temperature, °C

n is the number of terms for series convergence

L is the infinite slab thickness, m

t is the time of heating, s

x is the distance from the slab surface, m

α is the thermal diffusivity, $m^2 \cdot s^{-1}$

This equation can be expanded for n from 1 to ∞ to give a series expression (see Equation 2.7). The exponential terms simplify because $\sin \pi = 0$, $\sin \pi/2 = 1$ and $\sin 3\pi/2 = -1$.

$$\frac{RT - T}{RT - IT} = \frac{4}{\pi} \left[\frac{1}{1} e^{-1\alpha(\pi/L)^2 t} - \frac{1}{3} e^{-9\alpha(\pi/L)^2 t} + \frac{1}{5} e^{-25\alpha(\pi/L)^2 t} - \frac{1}{7} \dots + \frac{1}{9} \dots \right] \quad 2.7$$

Equation 2.7 represents the equation from the first part of the analysis; that is the analytical solution. Only the first three terms are given because it will be shown later that the magnitude of the further terms is insignificant at times of interest.

The second part of the analysis is the derivation of the equation for the semi-logarithmic plot shown in Figure 2.4. This method of analysis of time-temperature data for canned foods is done by plotting temperature data on a logarithmic axis, as degrees below the processing or retort temperature (Ball and Olson, 1957; Stumbo, 1965). Figure 2.4 shows an example of such data for a conduction heating meat pack in which the retort temperature was 250°F (121.1°C).

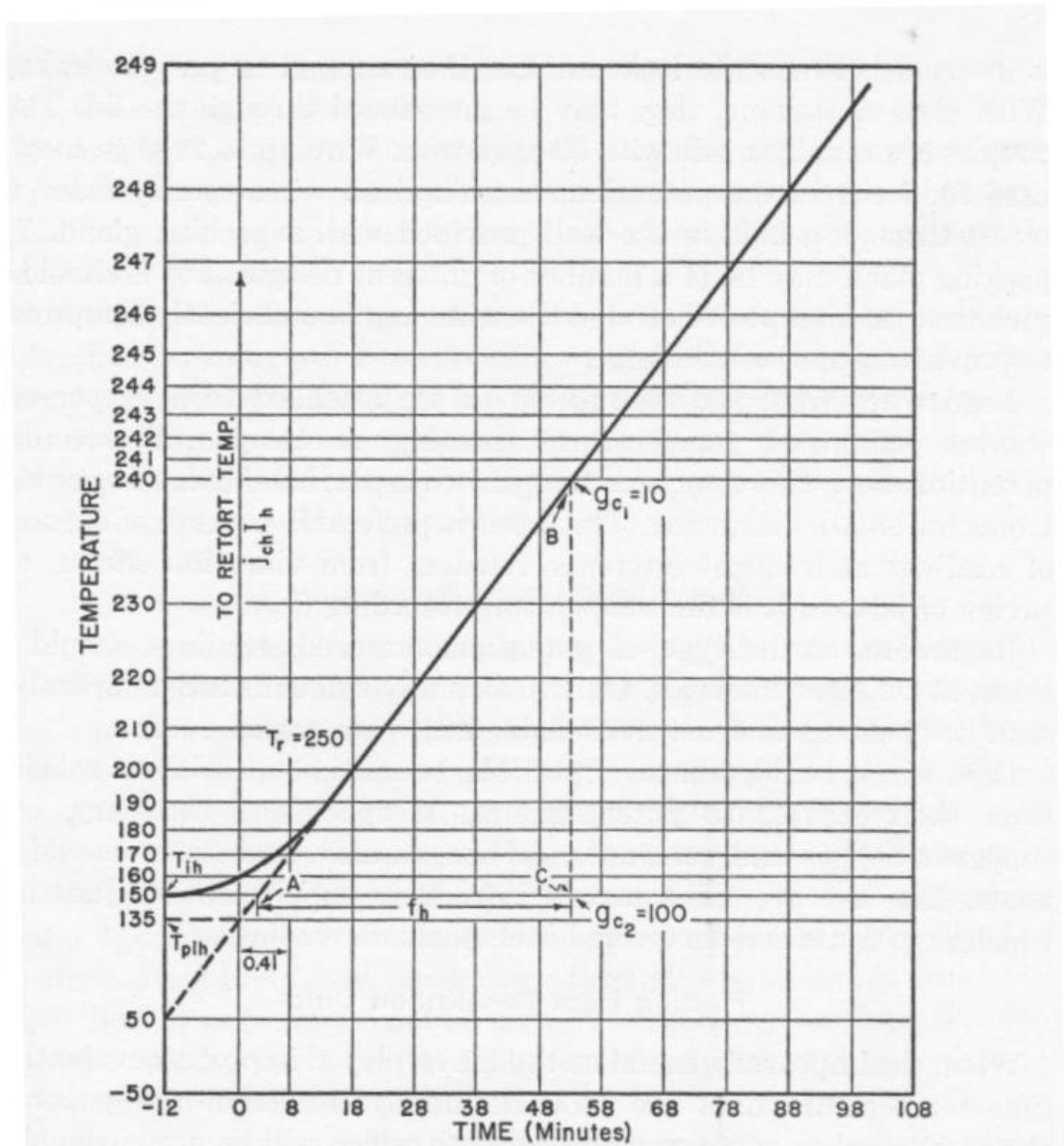

Figure 2.4: Logarithmic plot of time-temperature data for a meat product to illustrate the asymptote to the heating temperature (taken from Stumbo, 1965).

The equation for the logarithmic plot (Figure 2.4) is that for the asymptote of the line as the container centre temperature approaches the constant heating temperature. This can be defined mathematically as in Equation 2.8.

$$\frac{RT - T}{RT - IT} = j.e^{-2.303t/f_h} \quad 2.8$$

where, j is the heating lag factor, defined as a measure of the thermal lag before the can temperature responds to the changing environment temperature (IFTPS, 1997), dimensionless

f_h is the heating factor, defined as the temperature response parameter derived from the logarithmic heating curve (IFTPS, 1997), minutes

Equations 2.7 and 2.8 show distinct similarities, and when these equations are compared, the pre-exponential and exponential terms are as follows:

$$j = 4/\pi \quad 2.9$$

$$e^{-2.303t/f} = e^{-\alpha t (\pi L)^2} - \frac{1}{3} e^{-9\alpha t (\pi L)^2} + \frac{1}{5} e^{-25\alpha t (\pi L)^2} - \frac{1}{7} \dots + \frac{1}{9} \dots \quad 2.10$$

Therefore, the heating lag factor (j) for an infinite slab equates to a single numeric value, which is $4/\pi$ or 1.273.

Further simplification of Equation 2.10 is required to obtain the equation for the heating factor. The assumption is made that the series for the analytical solution (right side of Equation 2.10) converges with just the first term. For a conduction-heating product, as is the case for a food particle, this is a valid assumption and can be demonstrated with a simple set of data.

Table 2.1 shows values calculated from the exponential series in Equation 2.10; using a slab thickness (L) of 2 cm and a thermal diffusivity (α) of $1.6 \times 10^{-7} \text{ m}^2\text{s}^{-1}$ (a value appropriate for high water content foods; McKenna and Tucker, 1991). Only the $n=1$ term in Equation 2.10 is of significance for times relevant to the heating of food products. The $n=3$ and all higher order exponential terms rapidly diminish to a level in which these terms can be ignored for heating times greater than a few seconds. For example for the $n=3$ term, after 120 seconds of heating, the exponential term is 1.4×10^{-6} . Higher order terms are even smaller in value. Therefore, the data in Table 2.1 justifies the assumption that only the first term in Equation 2.10 is required for heating times greater than a few seconds.

Table 2.1: Terms for the n=1 and n=3 exponential functions in Equation 2.10. Thermal diffusivity was $1.6 \times 10^{-7} \text{ m}^2\text{s}^{-1}$ and slab thickness was 2 cm.

Time, t (seconds)	1st term (n=1)	3rd term (n=3)
0	1.000	1.000
120	0.622	1.4×10^{-6}
240	0.388	1.0×10^{-11}
360	0.241	9.0×10^{-17}

Eliminating the higher order exponents in Equation 2.10 to leave only the n=1 term results in Equation 2.11. This can be further simplified to Equation 2.12 by equating the exponents, substituting for π and re-arranging:

$$e^{-2.303t/f} = e^{-\alpha(\pi L)^2} \quad 2.11$$

$$f_h = \frac{0.233L^2}{\alpha} \quad 2.12$$

Equation 2.12 is significant because it relates the thermal diffusivity of the food directly to the heating factor and a dimension term. Ball and Olson (1957) calculated theoretical values for the heating and lag factors for a variety of geometrical shapes using solutions to the respective analytical solutions. These were more complex than the solution for the infinite slab presented here. Table 2.2 presents the solutions for common geometrical shapes.

Table 2.2: Theoretical lag factors and heating factors for common geometrical shapes (extracted from Ball and Olson, 1957). a, b and c are half dimensions.

Geometry	Lag factor at centre	Heating factor equation
1D infinite slab	1.273	$\alpha \cdot f_h = 0.933a^2$
1D sphere	2.000	$\alpha \cdot f_h = 0.233a^2$
2D cylinder	2.040	$\alpha \cdot f_h = 0.398/(1/a^2 + 0.427/b^2)$
3D brick	2.064	$\alpha \cdot f_h = 0.933/(1/a^2 + 1/b^2 + 1/c^2)$

Heating factor equations for the spherical (1D), cylindrical (2D) and rectangular (3D) geometries were used for calculating TTI particle sizes so they matched the thermal pathway for food pieces (by matching the f_h value). Most food particles can be approximated to one of these shapes.

For example, fruit particles approximated by cylinders of equal height and diameter (25 mm) can be represented by silicone TTI cylinders of 20.6 mm height and diameter. This calculation assumes that the thermal diffusivity for fruit is $1.5 \times 10^{-7} \text{ m}^2\text{s}^{-1}$ and for the silicone it is $1.02 \times 10^{-7} \text{ m}^2\text{s}^{-1}$ (McKenna and Tucker, 1991). Equation 2.10 is used to first calculate the heating factor (f_h), which is 290 seconds for the example of the 25 mm fruit particle. Note that for a cylinder of equal height and diameter ($a = b$) Equation 2.10 simplifies to Equation 2.11. The silicone thermal diffusivity value of $1.02 \times 10^{-7} \text{ m}^2\text{s}^{-1}$ is used with the heating factor (f_h) of 290 seconds to calculate the cylinder dimension; in this case it is the radius (a).

$$\alpha \cdot f_h = \frac{0.398}{\left(\frac{1}{a^2} + \frac{0.427}{b^2} \right)} \quad 2.10$$

$$\alpha \cdot f_h = 0.279a^2 \quad 2.11$$

This calculation procedure was used to estimate TTI particle dimensions based on the most appropriate food particle shape. The size and shape of TTI and food particles should be similar so that the heat transfer conditions experienced by both are also similar. If a silicone TTI particle is constructed with significantly different dimensions to a food particle then it is likely that the heat transfer coefficient between fluid and particle surface will be different. Amylase TTI data measured with such particles will thus not represent the process achieved at the core of the food particles.

2.5 Preparation of amylase solutions for use in TTI particles

Two existing amylase solutions were used for calculating thermal process values using the types of TTI particles described above. These solutions were first reported by Hendrickx et al. (1995), and their preparation is described as follows.

2.5.1 *Bacillus amyloliquefaciens* α -amylase at 85°C (BAA85)

This TTI was used for high acid products in the pH range 3.7 to 4.2 where the target was to exceed 5 minutes at 85°C (CCFRA, 1992a). It was referred to as BAA85 and consisted of 10 mg/mL BAA amylase in 0.05 M Tris buffer (pH 8.6 at 25°C). To prepare the solution, 20 mg α -amylase powder from *Bacillus amyloliquefaciens* (BAA) source (EC 3.2.1.1 Type II-A, Sigma A-6380) was dissolved in 2 mL of 0.05M Tris buffer (pH 8.6 at 25°C).

2.5.2 *Bacillus licheniformis* α -amylase at 90°C (BLA90) or 93.3°C (BLA93)

This TTI was used for acid products (BLA93) with pH between 4.0 and 4.4 where the target was to exceed 5 or 10 minutes at 93.3°C or for sous-vide products (BLA90) where the target was to exceed 10 minutes at 90°C (CCFRA, 1992b). It consisted of 10 mg/mL BLA amylase in 0.05 M Tris buffer (pH 8.6 at 25°C). To prepare the solution, 20 mg of α -amylase solution from *Bacillus licheniformis* (BLA) source (EC 3.2.1.1, Sigma A-4551) was dissolved in 2 mL of 0.05 M Tris buffer (pH 8.6 at 25°C).

2.6 Procedures for conducting the amylase assays

Stock solutions for the two types of amylase TTIs were prepared as above. Microlitre quantities (20-30 μ L) from these solutions were used directly within the TTI tubes, made according to the procedures given earlier in this chapter, section 2.2.

Tris buffer was used with both BLA90/BLA93 and BAA85 TTIs, and was prepared as follows (Adams, 1996; Van Loey et al., 1997a):

- Weigh 0.6057 g Trizma base (Sigma T-8524) (tris hydroxymethyl aminomethane)
- Add 100 mL deionised water
- Adjust the temperature to 25°C using a water bath
- Adjust pH to 8.5-8.6 using concentrated hydrochloric acid (Sigma H-7020), under a fume hood and using a Pasteur pipette.

Amylase assays were conducted using Randox Amylase ethylidene blocked-pNPG₇ kit (Randox Laboratories Ltd). This was used for all of the amylase assays with the exception of the sterilisation TTI. Randox provide a kit containing an amylase substrate and a buffer solution. These kits are supplied in quantities for 5 assays or 20 assays. Preparation instructions were according to the manufacturer's instructions, as follows:

- Allow the kit reagents to equilibrate to room temperature before opening.
- Reconstitute the contents of one vial of Substrate 2 with the 20 mL of Buffer 1 from the kit.
- Store the reconstituted substrate solution at 2-8°C for a maximum of 2 days otherwise the solutions could break down and give false assay readings.
- Do not use if the solution appears yellow in colour and the absorbance at 405nm exceeds 0.7 on a spectrophotometer.

The amylase assay procedures for BAA85 and BLA90/BLA93 were the same. These involved the following steps:

- Pipette 1 mL of the diluted amylase reagent solution into a cuvette.
- Dilute 10 µL of amylase solution with 290 µL of Tris buffer solution.
- Add 20 µL of the diluted amylase/Tris solution to the cuvette containing the 1 mL of reagent solution and mix by inversion.
- Place the cuvette immediately into the spectrophotometer chamber and start logging absorbance results. The spectrophotometer should be set at 405nm.

The amylase assay involved a reaction between the amylase solution and the starch-rich substrate, with maltose being released to create a yellow coloration of the solution.

Measurement of the rate at which the yellow colour forms constituted the assay, which can be expressed as an activity. The optimum temperature for obtaining the maximum reaction rate was at 30°C (Randox). A temperature-controlled cavity at 30°C was connected to the spectrophotometer and used to pre-warm the reagent to this temperature before the amylase solution was added.

The readings from the spectrophotometer were taken over a 1-5 minute period when the maltose was being released. This time period varied depending on whether the amylase solution was an unheated control or a heated sample. Highly active solutions, as with unheated control samples, showed this fastest gradient soon after starting the assay, whereas a sample with low activity required several minutes to reach a constant gradient. Thus, the region of highest gradient varied depending on the quantity of residual amylase activity.

Amylase activities were calculated from the gradient that represented the fastest reaction rate of the absorbance readings with time. Figure 2.5 illustrates a reaction rate curve for a control (unheated) amylase sample of BLA90 in which the initial rate is 0.024 s^{-1} .

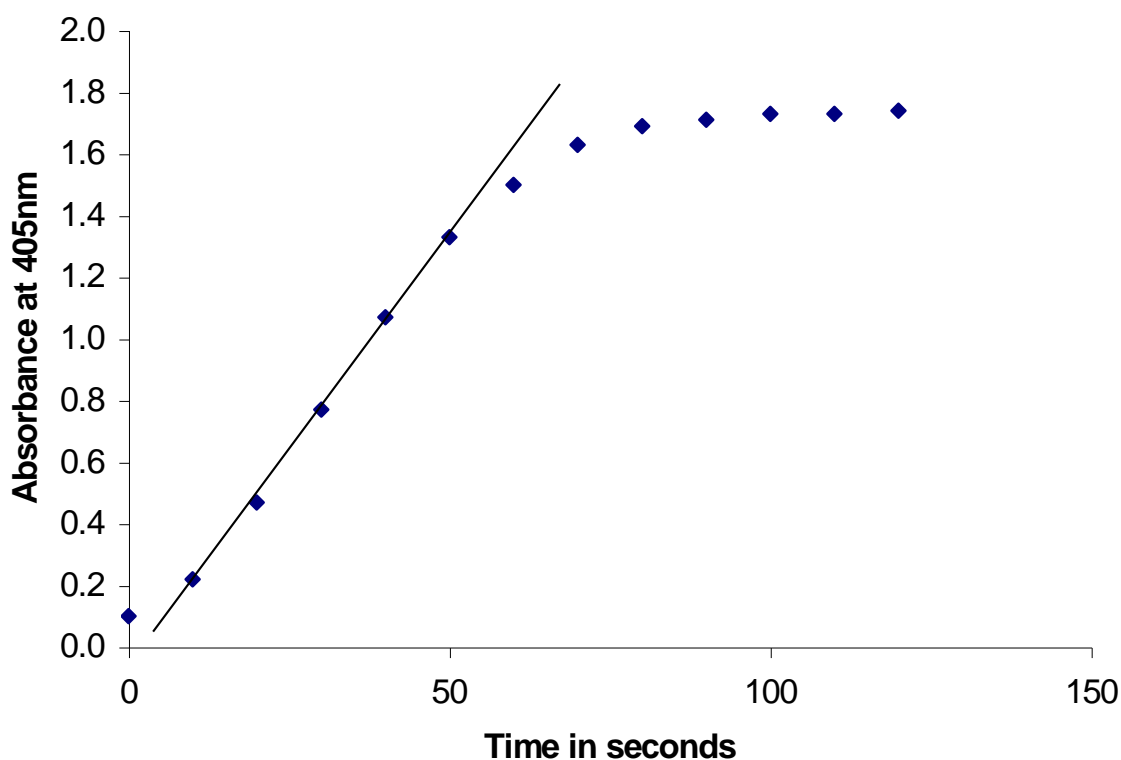

Figure 2.5: Sigmoidal reaction rate curve from a BLA90 amylase assay. Reaction rate of 0.024 s^{-1} is calculated from the highest value of the gradient.

2.7 Measurement and calculation of amylase D-values

Amylase powder was purchased from Sigma in 1 g pots, which was a large quantity sufficient to make many thousands of TTI tubes. Kinetic parameters for each new amylase pot were

determined in detail using isothermal experiments with the amylase solutions enclosed in glass capillary tubes and heated in a well-stirred water bath (Lambourne and Tucker, 2001). Once a pot of amylase was characterised in terms of its D- and z-values it was not necessary to re-measure these values each time a sample was taken from the pot (Tucker, 1999c).

Subsequent sub-samples taken from the 1 g of amylase powder required a calibration test conducted at the reference temperature prior to each individual TTI trial. For example, if the D-value of BAA85 was measured as 7 minutes at 85°C, the calibration test involved heating 3 replicate BAA85 tubes at 85°C for the equivalent time to the D-value, which in this example was 7 minutes. Minor differences in measured D-values of the order of ±5% were found from batch to batch (see data given in Chapter 4 for BAA85 and BLA90 solutions). These were thought to be caused by differences in amylase concentration, buffer consistency and variation in extracted volumes of amylase from the TTI tubes. This is discussed later in this chapter.

For the purposes of determining D-values at a heating temperature, Equation 1.6 was re-written using X_0 and X as the initial and final amylase activities respectively (see Equation 2.12). Equation 2.12 was re-arranged into Equation 2.13 so that data from more than one heating temperature could be plotted on one graph.

$$t = D_T \cdot \log\left(\frac{X_0}{X}\right) \quad 2.12$$

$$\log\left(\frac{X}{X_0}\right) = -\frac{t}{D_T} \quad 2.13$$

An average initial activity (X_0) was calculated from the TTI tubes reserved for unheated controls. The gradient of a graph of $\log X/X_0$ (rate of the heated sample divided by the rate of the unheated sample) against time was used to determine the D_T -value at each of the heating temperatures. A graph of the $\log D_T$ -value against temperature was used to determine the z-value, which is a measure of how sensitive the D_T -value is to temperature change.

Example kinetic data presented here illustrates two sets of heat stability data measured from BAA and BLA powder. For the BAA85, a decimal reduction time (D-value) of 6.8 minutes at 85°C was calculated (see Figure 2.6), whilst for the BAA90, the D-value was 8.8 minutes at

93°C (see Figure 2.7). The kinetic factors (z-values) were 9.4 C° for the BAA85 and 9.1 C° for the BAA90 (see Figure 2.8), both values being close to those for the target microbial species of 9-10 C° (CCFRA, 1992a and 1992b). This closeness in z-value is essential, as significant errors in the calculated process values can otherwise be introduced (Hendrickx et al., 1995; Van Loey et al., 1996). All kinetic parameters were determined by linear regression analysis from the isothermal experiments.

Knowledge of the D-value was critical for the amylase TTI systems because this was the key variable in the calculation step for P-value estimation (see Equation 2.3). Obtaining the highest accuracy in measuring D-values required considerable care because of the dilution steps outlined above. To minimise changes in D-value between sub-samples of amylase solutions taken from the same 1 g pot, the amylase solutions are prepared in sufficient quantity for use over many months, or years. This relies on frozen storage of the solutions in 1 mL vials that contain sufficient volume to prepare 25-40 TTIs for a typical industrial TTI trial (see Chapter 4). At the time of writing this thesis, we have a stock of BAA85 solution that is over 24-months old, and retains its heat stability properties each time a D-value calibration is carried out at 85°C.

Frozen storage of the amylase solutions in 1 mL vials was proven to cause minimal damage to the amylase heat stability properties; this is demonstrated in Chapter 3 for a new amylase TTI system. Once the amylase solutions were thawed ready for use, a check of the D-value at the TTI reference temperature was carried out to confirm that the D-value had not changed. This test required heating small volumes of the amylase solution at the reference temperature for a time equivalent exactly to its D-value. One log reduction in amylase activity should result from this heating.

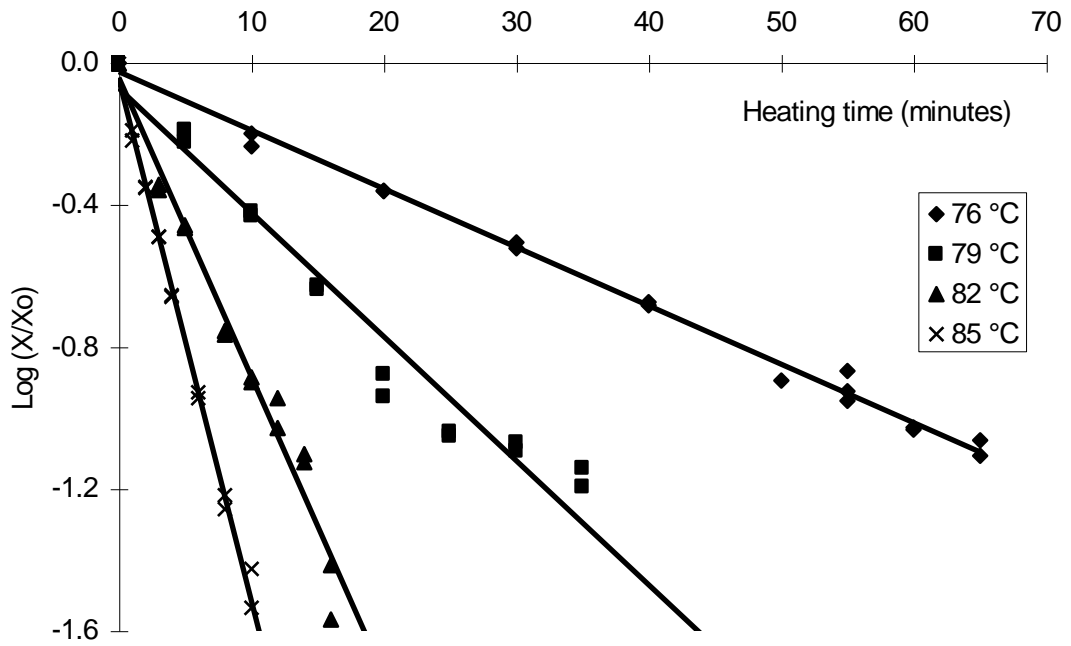

Figure 2.6: Heating time versus logarithm of amylase activity ratio (X/X_0), for BAA85 at heating temperatures of 76, 79, 82 and 85 °C; resulting in a D_{85} value of 6.8 minutes.

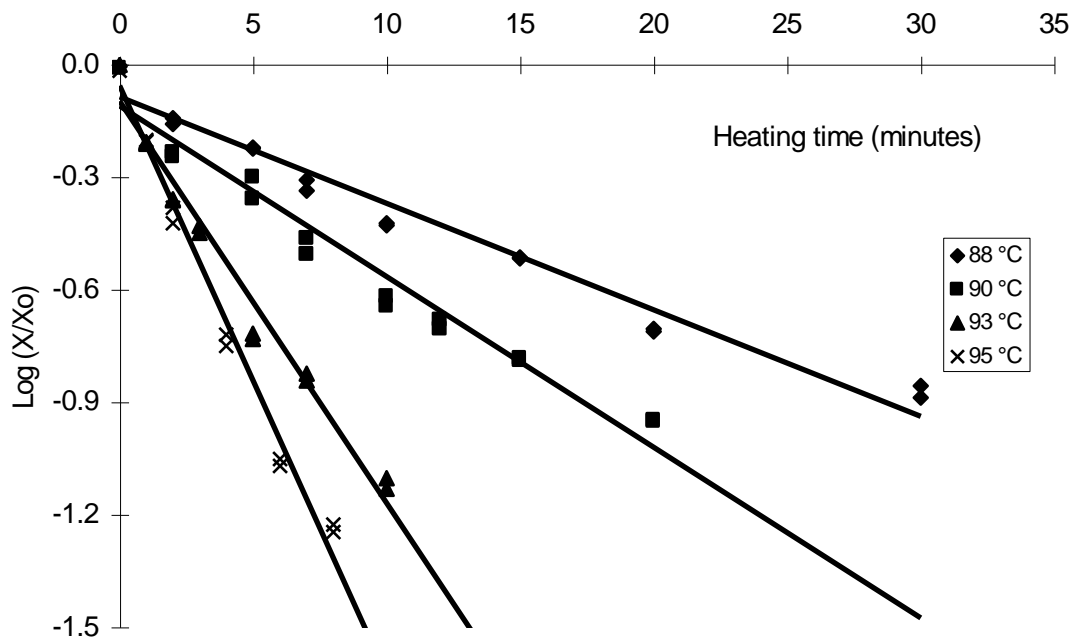

Figure 2.7: Heating time versus logarithm of amylase activity ratio (X/X_0), for BLA90 at heating temperatures of 88, 90, 93 and 95 °C; resulting in a D_{93} value of 8.8 minutes.

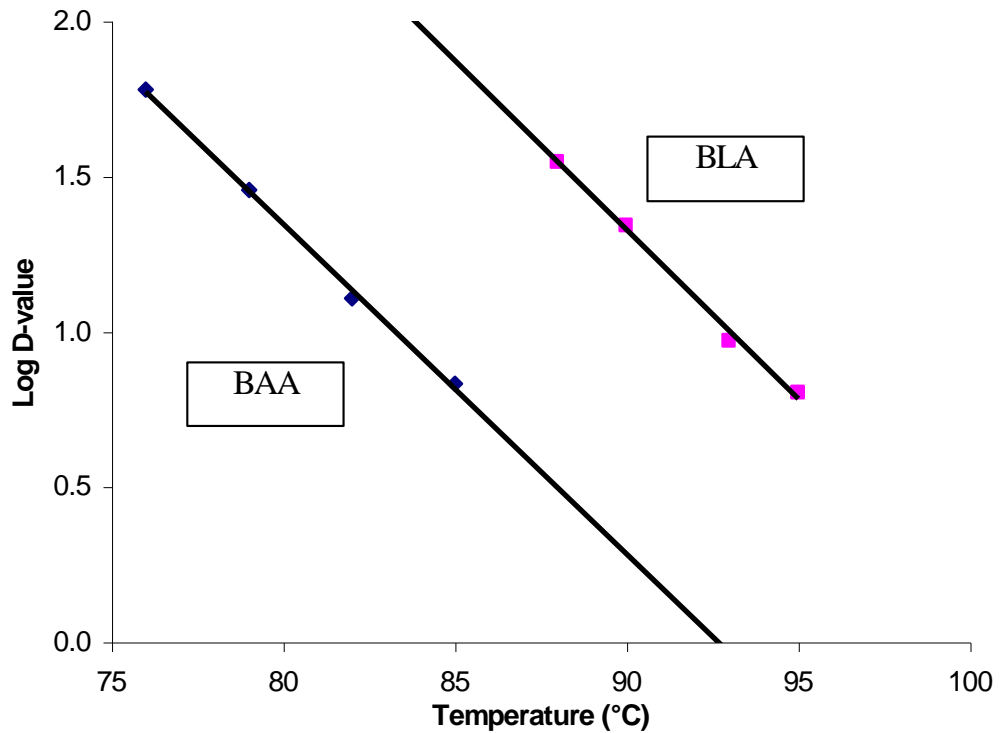

Figure 2.8: Logarithm of the D_T values against temperature: BAA85 with $z = 9.4 \pm 0.3^\circ\text{C}$ and BLA90 with $z = 9.1 \pm 0.3^\circ\text{C}$.

2.7.1 Adjustment of D-values for offset in calibration bath temperature

The D value is calculated from Equation 2.14.

$$D = -1 / \text{rate} \quad 2.14$$

where, *rate* is the maximum gradient calculated from a graph similar to that in Figure 2.5, minutes⁻¹

Adjustment of the D-value was sometimes required because the test (calibration) temperature could differ slightly from the bath setpoint temperature. This was likely to be caused by a temperature offset with the bath temperature control probe.

A further calculation was required to convert the D-value determined from the data at the water bath test temperature (TestTemp) to a value at the bath or reference temperature (T_{ref}). This conversion is given by Equation 2.15.

$$D_{(T_{ref})} = D_{(TestTemp)} \times 10^{\left(\frac{T_{TestTemp} - T_{ref}}{z}\right)} \quad 2.15$$

A D-value calculated from this calibration test should be close to values measured for other sub-samples taken from the same 1 g pot of amylase powder. Small differences up to 15% were measured, and were thought to be caused by variation in the following factors:

- weighed quantity of amylase powder and the proportion of amylase within the weighed milligram sample (there are high levels of salts in the commercial amylases),
- concentration of buffer components such as precise pH levels,
- concentration of Randox solutions (these are prepared by dissolving the substrate powder in buffer solution),
- microlitre volumes of amylase solution extracted from TTI tubes (typical extraction volumes are 10 μ L; a small air bubble within the syringe needle can account for 5% of the volume).

Repetition of the D-value test was carried out on the rare occasions that D-value differences were found to be greater than 15%.

2.8 Measurement and accuracy of P-values using TTI tubes

During development of the TTI particle methods, a series of trials were conducted to assess the accuracy of P-values measured using amylase encapsulated into silicone cubes. This was necessary to demonstrate that the amylase encapsulation method was of sufficient accuracy to be used for measuring thermal process P-values. The tests used 10 mm silicone cubes with 30-40 μ L of the BAA85 solution injected into an air bubble carefully set into position at the cube centres (at this early stage the encapsulation method used trapped air bubbles in silicone and not silicone tubing; Tucker, 1999c).

All of the tests were conducted in a vigorously boiling water bath for 3 minutes. Temperature data for the bath and at the centre of four silicone particles were recorded at 15 second intervals using a Grant Squirrel logger (Grant Instruments, Cambridge). On removal from the bath, the cubes were immersed in cold water to quench the amylase degradation reaction. Figure 2.9 shows the time-temperature data to the end of the boiling water bath for the four silicone cubes containing a thin-wire thermocouple at the centres.

Kinetic data for this BAA85 batch of amylase was represented by a z-value of $9.7 \pm 0.3^\circ\text{C}$ over the range 74.0 to 83.0°C , with a $D_{80.7}$ of 18.7 minutes. These measurements were made using glass capillary tubes in a glycerol bath. The D_T value was quoted at 80.7°C because this was the temperature of the glycerol bath at a set point of 80.0°C when it was checked with a NAMAS calibrated thermometer accurate to within $\pm 1^\circ\text{C}$. Conversion of $D_{80.7}$ to D_{85} used Equation 2.15.

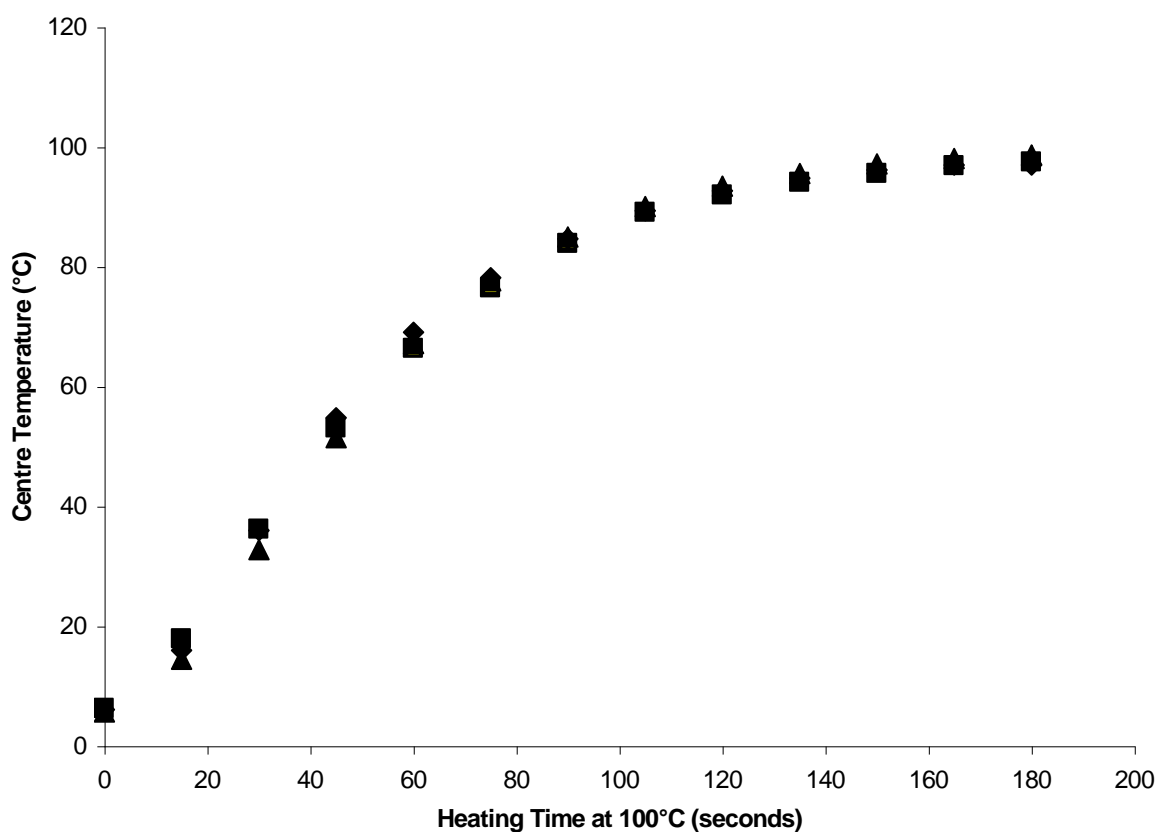

Figure 2.9: Time-temperature data to the end of the boiling water bath measured in four 10 mm silicone cubes each containing a thin-wire thermocouple at the centre.

TTI P-values from the same test were measured using 43 silicone cubes injected with BAA85. Ten cubes were retained as unheated controls, from which the initial amylase activity was determined. Mean, maximum and minimum values were compared with those from 0.2 mm type K thermocouple measurements at the centres of four cubes. Only four cubes contained probes at their centres because probe P-values were expected to be consistent.

P-values presented in Table 2.3 were calculated from the final amylase activities for 35 of the 43 TTI particles. It was found that 8 of the particles contained insufficient amylase activity to measure with sufficient accuracy. It was possible to conclude from a low amylase activity that a TTI particle had received a process equivalent to at least three log reductions in the D_{85} -value. This was the limit of measurement.

Table 2.3: P-values measured from 10 mm silicone cubes heated in a boiling water bath for 3 minutes; 35 BAA85 TTIs and 4 x thermocouples. z-value for BAA85 was 9.7°C.

	Mean P-value (minutes)	Highest P-value (minutes)	Lowest P-value (minutes)
BAA85 TTIs	15.7	22.8	11.0
Type K Thermocouples	17.7	20.9	15.3

A three log reduction in amylase activity was the measurement limit with a spectrophotometer reading to 3 d.p. Typical initial amylase activity for the BAA85 TTI was around 1.000 units/minute, therefore 3 log reductions in activity reduced this to 0.001 units/minute, which was the limit of resolution. High P-values calculated from amylase activities of ≤ 0.002 units/minute were on the limit of the spectrophotometer measuring accuracy. Correlation coefficients for the calculated gradients at ≤ 0.002 units/minute were below 0.91 whereas for values above 0.004 units/minute they were above 0.98.

Replicate measurements of activity were made from the buffer-diluted amylase solutions extracted from single TTIs. These were found to be within 2.5% for activities above 0.004 units/minute.

The mean TTI P-value was slightly less than that calculated from the thermocouple measurements; 15.7 minutes compared with 17.7 minutes. Equation 2.16 shows the calculation procedure for P-value from thermocouple measurements. Conduction of heat along the thermocouple wires during heating were the likely error source that could result in P-values higher than those measured with the TTIs. Figure 2.10 shows the mean TTI P-value at 15.7 minutes, with the 95% CI between 14.8 and 16.5 minutes.

$$P = \int_0^t 10^{\frac{T(t)-85}{9.7}} \cdot dt \quad 2.16$$

where, P is the pasteurisation or P-value, minutes

T(t) is the product temperature, which is a function of time, °C

85 is the reference temperature for the D_T value, °C

t is the process time, minutes

9.7 is the z-value or kinetic factor, °C

Obtaining an exact match of P-values between TTIs and thermocouples was experimentally difficult because of the uncertainty with temperature measurements in particles of small size. This is one justification for using TTIs. Errors with wire-based systems can arise due to heat conduction, capillary action of the hot water along the thermocouple hole, and in the precise location of the measuring junction at the centre. Type K thermocouples were used in these trials (chrome - alumel) because they were less prone to thermal conduction than the more conventional type T (copper - constantan). However, in a 10 mm cube, the thermocouple junction is only 5 mm from the environment temperature, and it is certain that some heat conduction must occur.

Conclusions from this 10 mm cube trial were that the TTIs provided P-value results similar to those from thermocouples, and were therefore a measurement method with suitable accuracy for industrial process work.

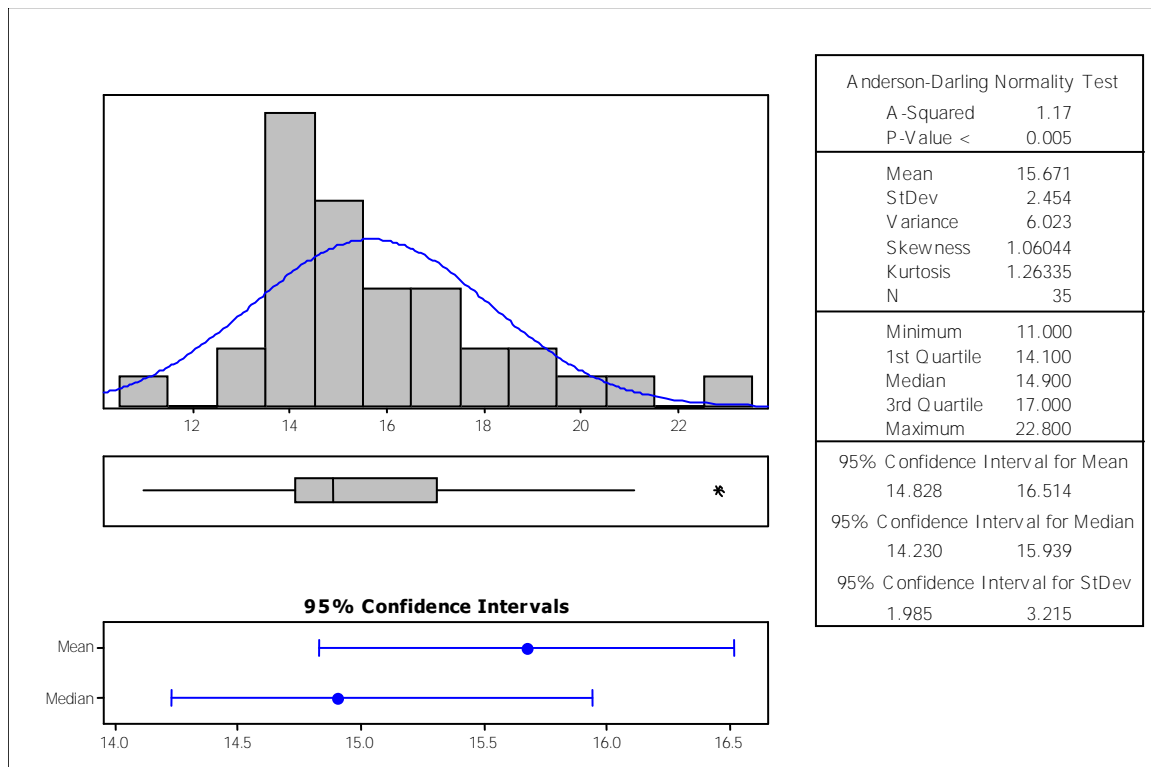

Figure 2.10: P-value distribution for the 35 BAA85 TTI particles immersed in a boiling water bath. Data was not normally distributed because of the influence of high P-values.

These P-value data from the 35 BAA85 TTIs presented in Figure 2.10 were prepared using one of the standard outputs from the Minitab statistical package. Chapter 4 presents many more similar figures of TTI data and so an explanation of the figures is first given here; and is not repeated in Chapter 4. Information on the statistical parameters that describe the set of P-value data are given in the table of numbers to the right of the three plots. Not all of this information is used in analysing the data from TTI trials reported here but it is convenient to present the graphs in the format prepared by Minitab. In each figure, there are three plots presented:

- A frequency distribution of P-values on the abscissa against frequency of occurrence on the ordinate axis. A line representing a normal distribution of the data is included.
- A line plot showing the 1st to 3rd quartile ranges as shaded boxes with the mean P-value as a single vertical line. The range between the highest and lowest P-values is shown by

the horizontal lines either side of the shaded boxes. Outliers, if present, are shown with an asterisk.

- 95% confidence intervals for the mean and median P-values.

2.8.1 Discussion on TTI accuracy

Calculation of error in a measurement system requires estimates to be made for the likely error in each of the component measurements. For example, if a temperature sensor is quoted as $\pm 0.5^\circ\text{C}$ at the reference or test temperature, this can be converted to a % error in terms of pasteurisation or sterilisation units. The basis for this calculation is given in Equation 2.17 for a sterilisation value (F_0) and in Equation 2.18 for a pasteurisation value (P).

$$\%F_0\text{error} = 100 \times \frac{F_0(T \pm \varepsilon) - F_0(T)}{F_0(T)} \quad 2.17$$

$$\%P\text{error} = 100 \times \frac{P(T \pm \varepsilon) - P(T)}{P(T)} \quad 2.18$$

where, F_0 is the sterilisation value specifically for destruction of *C. bot.* spores, minutes

P is the pasteurisation value, minutes

T is the test temperature, $^\circ\text{C}$

ε is the temperature offset from the correct test temperature, $^\circ\text{C}$

Equations 2.17 and 2.18 can be modified to a general form given in Equation 2.19 by substituting Equation 2.2 for each F_0 or P term. Equation 2.19 takes the same form whether the % error is for F_0 or P-value.

$$\%P\text{error} = 100 \times \frac{10^{[(T \pm \varepsilon) - T_{ref}]/z} - 10^{(T - T_{ref})/z}}{10^{(T - T_{ref})/z}} \quad 2.19$$

where, T is the food temperature, $^\circ\text{C}$

T_{ref} is the reference temperature for microorganism destruction or for amylase breakdown by heat, $^\circ\text{C}$

z is the kinetic factor for microorganism destruction or for amylase breakdown by heat, °C

Figure 2.11 shows how the % error increases for temperature offsets between 0 to 1.0°C from the reference temperature of 85°C, for a BAA85 example with z -value of 9.4°C. Typical errors with temperature sensors such as thermocouples can be 0.2-0.4°C, which results in P-value errors between 5.0 and 10.4%.

Equation 2.19 appears to contain just one variable, the measured food temperature (T), with reference temperature (T_{ref}) and z -value being fixed for a microorganism or TTI system. Hence, the standard methods to estimate errors based on \pm errors in the temperature measurement provide low % errors for P-values calculated from temperature probes. This assumes there are no error in the values of T_{ref} or z used in Equation 2.19.

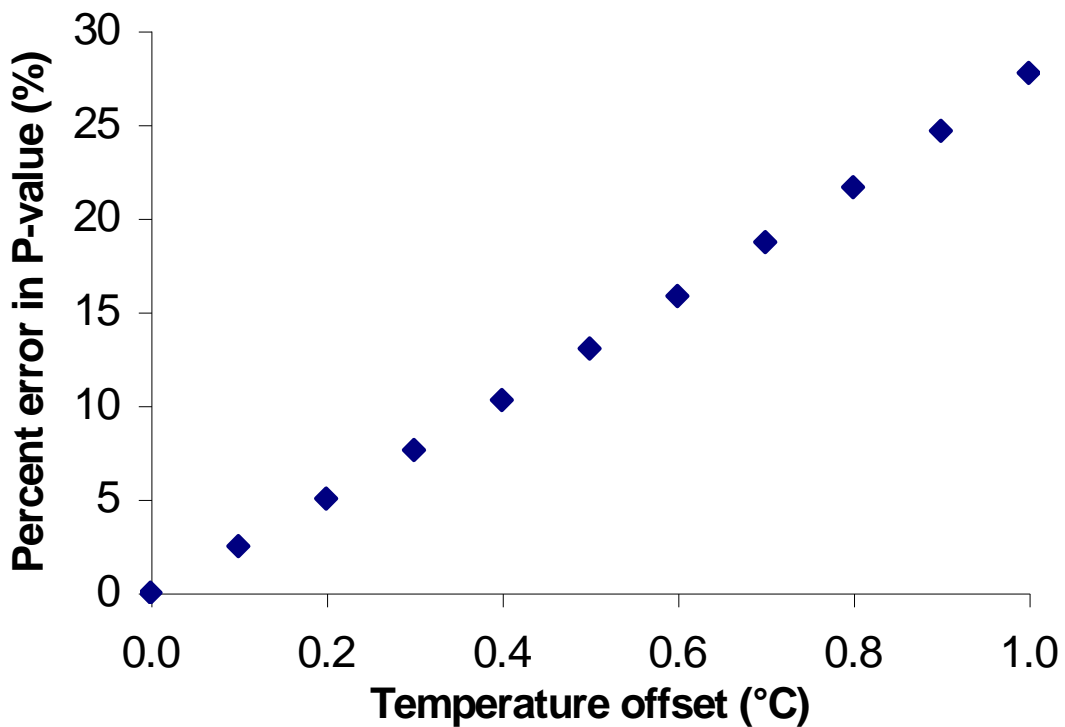

Figure 2.11: Error increase for P-values measured with temperature probes, for temperature offsets 0 to 1.0°C. BAA85 z -value was 9.4°C.

P-values calculated from TTI activity readings are more complex because they involve an amylase activity measurement before and after the time-temperature process. Equation 2.3 (repeated here as 2.20) shows the calculation of a P-value based on TTI measurements. Figure 2.12 illustrates how the calculated P-value maximum and P-value minimum can change depending on the absolute value of amylase activity, specifically the final activity after a heat treatment. Estimated error in activity measurement was taken as $\pm 10\%$ on both initial and final activity measurements. These estimates are realistic and based on experiences from spectrophotometer measurements. Initial activity was fixed at 1.000 units/minute for the error calculation. Data for Figure 2.12 was calculated using typical BAA85 data; that is a D_{85} -value of 8 minutes and an initial amylase activity of 1.000 minutes⁻¹ (as shown in Equation 2.21).

$$P = D_T \cdot \log\left(\frac{A_{initial}}{A_{final}}\right) \quad 2.20$$

$$P = 8.0 \cdot \log\left(\frac{1.000}{A_{final}}\right) \quad 2.21$$

It can be seen from Figure 2.12 that the difference between maximum and minimum P-value is greatest at higher values for amylase activity. These occur in a heat process when the thermal effects are minimal and little change in amylase denaturation occurs. This effect is highlighted when these P-value differences are converted to % errors in P-value, as shown in Table 2.4. Small reductions in amylase activity can result in the TTI measurements being subject to high errors in the calculated P-values. For example, for an initial activity of 1.00 minutes⁻¹ and a final activity of 0.70 minutes⁻¹, the calculated P-value of 1.24 can range from 0.54 to 1.61 minutes. This equates to % errors of -56.3 to $+29.5$. However, if the change in amylase activity from the heat process is significant, then the TTI measurement system is more accurate. For example, if the final activity is 0.10 units/minute, the calculated P-value of 8.00 can range from 7.30 to 8.37 minutes, which equates to % errors of -8.72 to $+4.58$. Figure 2.13 illustrates how the % error in TTI P-value reduces as a function of amylase activity measurement.

Table 2.4: Calculated P-value maximum and minimum heat treatment. A_{initial} was 1.000 units/minute, D_{85} -value 8 minutes. Error in activity measurement was taken as $\pm 10\%$.

Final amylase activity (units/minute)	P-value (minutes)	P-value Maximum (minutes)	P-value Minimum (minutes)	+% error	-% error
0.70	1.24	1.61	0.54	29.54	-56.26
0.65	1.50	1.86	0.80	24.46	-46.58
0.60	1.77	2.14	1.08	20.63	-39.28
0.55	2.08	2.44	1.38	17.62	-33.57
0.50	2.41	2.77	1.71	15.20	-28.95
0.45	2.77	3.14	2.08	13.19	-25.13
0.40	3.18	3.55	2.49	11.50	-21.90
0.35	3.65	4.01	2.95	10.04	-19.11
0.30	4.18	4.55	3.49	8.75	-16.67
0.25	4.82	5.18	4.12	7.60	-14.48
0.20	5.59	5.96	4.89	6.55	-12.47
0.15	6.59	6.96	5.89	5.55	-10.58
0.10	8.00	8.37	7.30	4.58	-8.72
0.05	10.41	10.77	9.71	3.52	-6.70

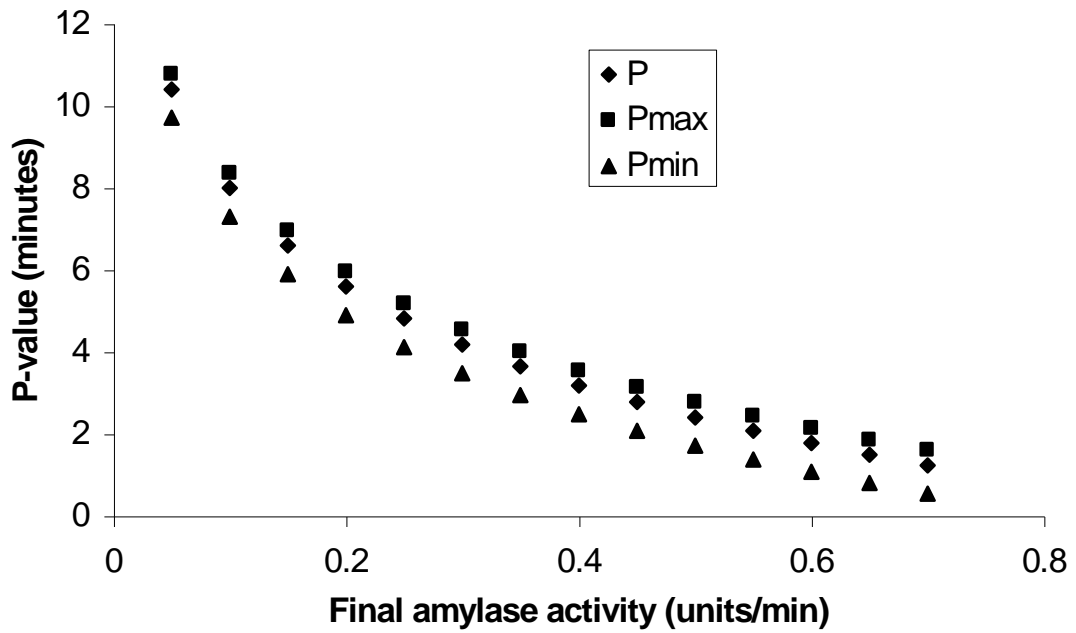

Figure 2.12: Calculated P-value maximum and minimum heat treatment. A_{initial} was $1.000 \text{ minutes}^{-1}$, D_{85} -value 8 minutes. Error in activity measurement was taken as $\pm 10\%$.

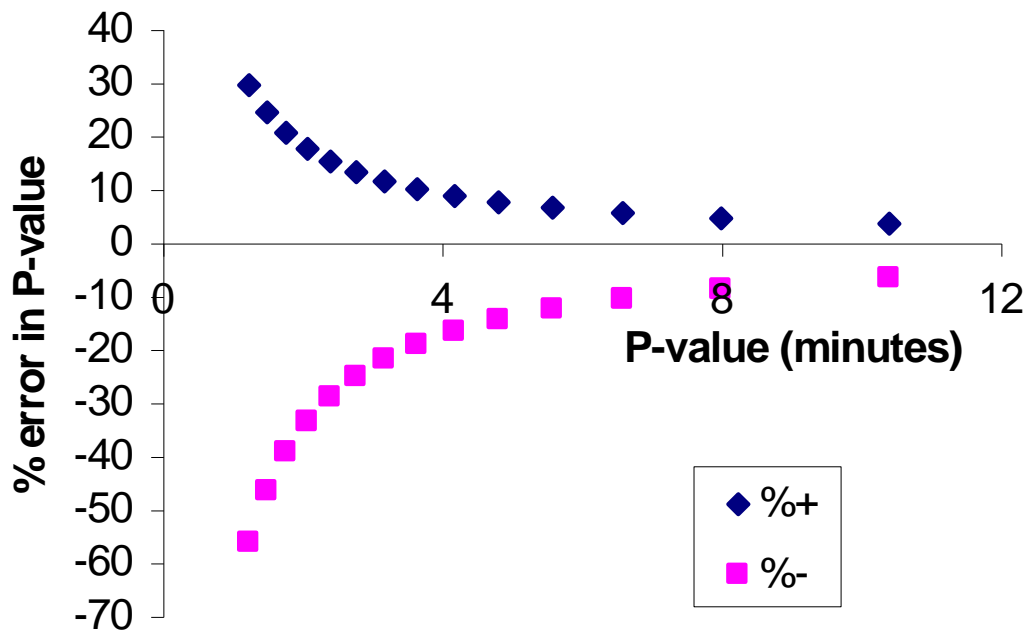

Figure 2.13: % errors in P-value as a function of the final amylase activity after a heat treatment. A_{initial} was $1.000 \text{ minutes}^{-1}$, D_{85} -value 8 minutes. Error in activity measurement taken as $\pm 10\%$.

One further comment on the accuracy of P-values calculated from TTI measurements concerns the accuracy of gradient calculations with high and low activity values. Figure 2.5 shows a typical time-absorbance curve measured with an instrument such as a spectrophotometer. Amylase activity is calculated from the gradient of the steepest part of the reaction curve. High amylase activities tend to occur quickly on this curve, often in the first 10 to 30 seconds, and so the sample needs to be handled efficiently when placing the cuvette into the spectrophotometer. Missed absorbance data can lead to erroneous gradients. At the other end of the scale, a low amylase activity will take several minutes for the initial curve to become straight, and it is important to leave the test running for enough time to reach a consistent gradient. Automation of this procedure is not easy unless each test is allowed to run for at least 10 minutes.

At the extremity of the three log measurement range for a Unicam spectrophotometer (as used in the work reported in this thesis), activities of 0.001 to 0.003 minutes⁻¹ resulted in lower accuracy when calculating the gradients. This has implications when converting activities to P-values. P-values calculated from activities of 0.001 and 0.003 minutes⁻¹ are 24.0 and 20.8 minutes respectively, using the same D-value of 8 minutes at 85°C as used for the above error analysis. As absolute values, these P-values represent a significant difference in P-value for only a 0.002 difference in measured activity, and can thus (and falsely) give the impression that TTI accuracy is suspect.

It is therefore important that the correct choice of TTI is made for an industrial trial so that the target P-value represents around one log reduction in amylase activity. Table 2.4 shows that at one log reduction levels for amylase activity (A_f 0.1 minutes⁻¹) the % errors are only -8.7 to +4.6, which are acceptable and within those expected for P-values calculated from temperature sensors. Chapter 4 provides further details of industrial TTI trials in which choice of TTI is critical.

2.9 Selection of TTI storage conditions

One of the advantages of using amylase TTI particles as a process measurement method is that the amylase is stable at room temperature for a considerable period of time (Lambourne

and Tucker, 2001). This can be shown by calculating a decimal reduction time at 25°C (D_{25} -value) for BAA85 of 19.3×10^6 minutes, using a T_{ref} of 85°C and assuming a D_{85} -value of 8 minutes and a z of 9.4 C° (Tucker and Wolf, 2003). Thus, to achieve a one log reduction in amylase activity would take 19.3×10^6 minutes or 36.7 years at 25°C. This does however assume that the kinetic data can be extrapolated from 85 down to 25°C, which is unlikely, but does illustrate the high degree of stability of these amylase solutions.

In practice, it is recommended to use chilled or frozen storage for amylase TTIs because of the potential for microbial growth within the non-sterile solutions that comprise the amylase solutions (Lambourne and Tucker, 2001). Microbial growth can change the pH of the buffer solutions and in doing so affect the mechanisms by which the amylases breakdown, which in turn can change the D and z values. For example, *Bacillus licheniformis* raises the pH as it metabolises (Montville, 1982). Growth of microorganisms such as *Bacillus licheniformis* can also result in natural amylases being released by the metabolising microorganisms, which will interfere with the required heat stability properties. It would be inconvenient to prepare the buffer solutions and construct the amylase TTI tubes within an aseptic environment, which is the level of security required to prevent the ingress of microorganisms. Instead, care needs to be taken when storing the amylase TTIs.

Previous industrial work using amylase TTIs has demonstrated that TTI tubes containing either BAA85 or BAA90 were best kept chilled in water or frozen (Tucker, 1999c). These two TTI types were stable in the silicone tubes and gave repeatable results following storage periods of up to 4-weeks chilled. More recent work on the new BAA70 TTI suggested that TTI tubes should be stored in their buffer solutions in order that any uncertainty was removed with molecular migration through the semi-permeable silicone tubing. Chapter 3 presents data and discusses these stability issues in detail for the BAA70 TTI. For consistency with different TTIs and to prevent mistakes being made with different storage regimes, it is best to store all types of TTI tubes in their buffer solution rather than water. Storage time for filled TTI tubes should be a few days under chilled conditions (5 to 8°C) or indefinitely in a freezer (-12 to -18°C).

2.10 Methods of applying TTIs to food processes

There are numerous methods by which amylase TTIs can be applied to food processes. Table 2.5 illustrates some of the methods used for trials with industrial processes; some of those regarding fruit products are described in more detail in Chapter 4. Issues dealing with representative introduction of TTIs to food processes and recovery of all processed TTIs are also covered in Chapter 4.

Table 2.5: Examples of TTI applications with food products, to illustrate different methods of applying TTI tubes and TTI particles.

Process Description	Method for applying TTIs to process
Continuous heating of fruit products in tubular, scraped surface or ohmic ¹ systems.	TTI tubes embedded into Sylgard 184 particles that represent the thermal characteristics of target particles (Tucker et al., 2002).
Surface pasteurisation in hot-fill ² applications.	TTI tubes stuck (using non-acetic acid sealant) to the inside surfaces of pots, bags, cartons or jars (Tucker and Wolf, 2003).
Continuous oven cooking-cooling of poultry pieces ³	TTI tubes inserted through drilled holes into fresh or frozen meat (Tucker et al., 2005).
Spin heating and chilling a large bags ⁴ of sauce or egg.	TTI tubes put into liquid egg and allowed to flow with the egg, or stuck to the inside surfaces (Tucker et al., 2005).
Sous-vide processing ⁵ of ready meals.	TTI tubes inserted into different parts of the food (Tucker et al., 2005).
Giusti-style of vessel processing ⁶ of sauces and particle mixtures	TTI tubes and/or TTI particles put into batch prior to heating and retrieved after processing from bulk packages or vessel (Tucker et al., 2002).

1. Ohmic: This is an electrical method of heating in which the food is pumped up a vertical column containing a series of electrodes (Skudder, 1988). Current passes through the food

and under the correct conditions the components with greatest resistance to electricity heat preferentially (De Alwis and Fryer, 1990a). Ideal for high viscosity foods with large particles, for example fruits.

2. Hot-fill: Heat from the cooked (and pasteurised) food is used to pasteurise the inner pack surfaces, sometimes with a short raining water process to 'top-up' the pasteurisation. Common with acidic foods in glass jars and plastic pots, for example cook-in-sauces.

3. Continuous poultry cooking: Linear or spiral ovens are used to cook poultry products that travel through steam and/or hot air sections on mesh belts. Products are typically ready-to-eat or frozen for incorporation into ready meals.

4. Spin heating or chilling: This process was designed for high viscosity sauces that are difficult to cool. The sauces are cooked in steam jacketed and/or steam injected vessels, then filled hot into plastic bags that are sealed at each end by a metal clip. The bags go into a large vessel filled with chilled water that rotates and in doing so agitates the bags until the sauce is below 3°C. Products are then used as ingredients for chilled ready meals.

5. Sous-vide: This was invented in France for the manufacture of high quality restaurant style meals. Foods are vacuum packed and cooked (pasteurised) in water baths, before being moved to a chilled water bath until below 3°C. Packs can be single serve to several kilos. Examples of products are joints of meat in sauces, ready meals.

6. Giusti: A style of vessel that uses a steam jacket, sometimes direct steam injection as well, with scraped surface agitation. Products can contain large particles.

2.11 Conclusions

Preparation of an amylase TTI for an industrial trial involved a number of steps. It was found that encapsulating the amylase solution in a silicone tube was the most convenient method, which resulted in a strong yet flexible cylinder containing the amylase TTI solution. Many of the industrial processes where TTIs were used to gather P-value data required the amylase TTIs directly in the form of tubes. These could be glued to container surfaces or inserted

directly into solid foods. One further advantage of using a tube was that it could be easily moulded into silicone food particles whose size was calculated so that the food and TTI particles heated at similar rates (McKenna and Tucker, 1991). Equations were derived from work in the canning industry that enabled the particle sizes to be calculated that gave equivalent process values. Choice of a silicone compound (Sylgard 184 or 170) with similar thermal and physical properties to high water content foods allowed the food and moulded TTI particles to behave in a similar manner to food pieces. This overcame any concerns with differences in the way that food and TTI particles moved in a food carrying liquid, or in different rates of heat transfer from carrying liquids to particle surfaces.

CHAPTER 3: DEVELOPMENT OF A NEW TIME-TEMPERATURE INTEGRATOR FOR MILD PASTEURISATION PROCESSES

‘Discovery consists of seeing what everybody else has seen and
thinking what nobody has thought’

Albert Szent Gyorgyi, Nobel Prize Laureate

This chapter describes the development of a new TTI for the measurement of mild pasteurisation treatments. The objective of mild pasteurisation is to achieve a process of the order of a few minutes at 70°C at the core of the food. Food products that receive these treatments are either (i) intended for sale under refrigerated conditions for up to ten days storage time, or (ii) are naturally high in acid that allow ambient storage for many months. Methods for using this TTI in industrial processes are identical to those described in Chapters 2 and 4, but the amylase solution is different and there are minor differences in assay technique.

Data from kinetic experiments at and around 70°C are described. These used well stirred water baths and a circulating silicone oil bath. Despite the high level of temperature control, the latter was not ideal because the TTI tubes dried out when heated in oil for extended lengths of time. Comparisons of D and z-value are given to demonstrate this drying effect.

To enable P-value measurements immediately after an industrial TTI trial, an alternative assay method is described that used a portable colorimeter rather than the lab-based spectrophotometer. The colorimeter did not have sample temperature control and so a heating effect from the colorimeter bulb was of concern. Issues that are dealt with include the relative accuracy between assays with the two instruments, and repeatability with colorimeter assays.

The final part of this chapter presents four industrial experiments that demonstrate applications for this new TTI.

3.1 Introduction to mild heat treatments

As discussed in Chapter 1, the most heat-resistant pathogen that might survive the thermal processing of low-acid foods is the spore-forming organism *Clostridium botulinum*. All thermal processes target this organism if no other effective hurdle to its growth is present. However, there is a growing trend to harness natural antimicrobial hurdles and to apply additional hurdles that allow food manufacturers to use milder heat treatments referred to as pasteurisation (CCFRA, 1992).

Pasteurisation is nowadays used extensively in the production of many different types of food, such as fruit products, pickled vegetables, jams and ready meals (CCFRA, 2006b). Food may be pasteurised in sealed containers (analogous to canned foods), or in continuous processes analogous to aseptic filling operations. It is important to note that pasteurised foods are not free from microorganisms and will rely on other preservative mechanisms to ensure their extended stability for the desired length of time.

Food products sold chilled with up to 10-days shelf life are currently required to receive a pasteurisation treatment at least equivalent to 2 minutes at 70°C at the product thermal centre (DoH, 1989). These products include cooked poultry, meat as an ingredient for ready meals, the ready meals themselves, plus a wide range of pies, pastries, soups and sauces for the high quality end of the market. Microorganisms of concern with this group of foods are the aerobic pathogens; this includes *Listeria monocytogenes*, *Salmonella* spp. and *E. coli*. These exist only as vegetative cells.

One further group of foods given a mild pasteurisation of around 2 minutes at 70°C are those naturally high in acid, such as fruits. Yeasts and moulds are microorganisms that can thrive in high acid conditions and therefore spoilage from these fungi is the primary concern for commercial production of fruit products. The recommended process for high acid fruit products, with pH below 3.7, is to achieve at least 2.1 minutes at 70°C (Put and de Jong, 1982; CCFRA, 1992a). This achieves six log reductions in ascospores of *Saccharomyces cerevisiae* (D_{60} 22.5 minutes, z 5.5°C), which is the target microorganism.

Data must be obtained by a food manufacturing company that proves that these process levels have been delivered. A TTI with heat stability in the range from 2 to 20 minutes at 70°C

allows these measurements to be made. As with the other TTI systems, applications for the mild pasteurisation TTI are for the types of products or processes that present difficulties with temperature probe-based systems. These include heated vessels with scraped surface agitation, continuous hot air ovens, water baths and fryers, and pasteurisation at container surfaces for hot-filled products.

3.2 Potential TTI systems

A number of possible TTI systems, all based on enzymes, showed potential as candidates for mild pasteurisation processes (see Table 1.3). However, the large z-values in most enzyme systems eliminated them as candidate TTIs because most microorganism death kinetics are typified by z values in the range 6 to 12°C (see Table 1.1). Many of these data in Table 1.3 originated from the frozen foods industry where a blanching step is performed prior to freezing. Blanching is intended to inactivate the majority of the enzymes without imposing excessive thermal damage to the food, hence it uses relatively mild temperatures (90 to 100°C) and short heating times (1 to 10 minutes). The renewed enzyme activity that often seems to be present in the thawed food after frozen storage is attributed to enzyme regeneration. It was important when choosing a suitable enzyme for use as a TTI that regeneration did not occur (Adams, 1978).

Enzymes are produced during microbial spoilage of foods and are often involved in the breakdown of texture. Many of the microorganisms that secrete enzymes are moulds, however, there are bacterial species (e.g. *Bacillus subtilis*, *Bacillus amyloliquefaciens* and *Bacillus licheniformis*) that produce heat stable amylases (De Cordt et al., 1992; Hendrickx et al., 1995). Amylase enzymes degrade starches, particularly naturally occurring starches, with the detrimental effect that the viscosity of the food is reduced as the macromolecular starch granules are broken down into their constituent sugars (Hutton, 2004). Other complex reactions can occur, for example, *Rhizopus* species cause softening of canned fruits by producing heat-stable pectolytic enzymes that attack the pectins in the fruit. *Mucorpiriformis* and *Rhizopus* species also cause breakdown of texture in sulphite-treated strawberries as a result of similar production of enzymes (Hutton, 2004). *Byssochlamys* species have been considered responsible for the breakdown in texture of canned foods, particularly

strawberries, in which they are commonly found. This is a heat-resistant mould that requires temperatures in excess of 90°C for several minutes to adequately destroy it (CCFRA, 1992b).

Not all candidates for the mild pasteurisation TTI were based on enzymes, however, those that showed ideal characteristics of a high D_{70} -value and similar z -value to that for vegetative cells were enzymatic. Some of these are described below.

A novel exogenous time-temperature integrator (TTI) based on an amperometric glucose oxidase biosensor was presented by Reyes de Corcuera et al. (2005). The TTI consisted of the enzyme entrapped within an electrochemically generated poly(o-phenylenediamine) thin film deposited on the interior wall of a platinum (Pt) or a platinized stainless steel (Pt-SS) capsule. After thermal treatment, the TTI was mounted in a continuous flow system and connected to a potentiostat for continuous amperometric detection of residual enzyme activity. A measurement was completed within 10 minutes. Isothermal treatments were carried out between 70 and 79.7°C. Thermal inactivation of the immobilized enzyme followed apparent first-order kinetics with z values of 6.2 ± 0.6 and 6.6 ± 0.8 °C for Pt and Pt-SS capsules, respectively.

Another potential TTI system was based on the fluorescence emission of R-phycoerythrin (R-PE) with specific interests in its use to estimate the degree of inactivation of food pathogens such as *Salmonella* (Vaidya et al., 2003). Isothermal data was taken to determine the kinetic parameters based on a general n th order reaction. Several non-isothermal experiments were also conducted over the same temperature range of the isothermal study. Very good agreement was obtained between theory and experiment at temperatures of 62.8°C and above. However, the model slightly under-predicted the extent of fluorescence emission decay at 60°C. Results indicated that R-PE fluorescence emission decay kinetics were well behaved and that the protein was a strong candidate for use as a time-temperature integrator.

Guiavarc'h et al., (2003) extracted, purified and characterized pectinmethylesterases (PME) from cucumber and tomato fruits and tested them as candidate TTIs. Thermal stability of purified PME was assessed at 55-77°C in the presence of several sugars or polyols, including sucrose, trehalose, mannitol, sorbitol and glycerol. Inactivation curves were biphasic and 1st order for cucumber-PME and tomato-PME, respectively, and both enzymes were stabilized by the presence of glycerol. Stabilization of tomato-PME by hydroxyl groups was exponentially

related to the number of these functional units. The purified enzymes were further considered as time-temperature integrators (TTI) for the assessment of pasteurization processes.

Although the fruits provided a readily available source of enzymes, the preparation steps and natural variability in raw materials were considered excessive for use as a TTI.

The most promising TTI system was an amylase from bacterial origin that could be obtained commercially as a pure powder; this was the basis for the new TTI for mild pasteurisation treatments. Tomazic and Klibanov (1988) studied a range of *Bacillus* α -amylases with irreversible thermal inactivation properties. One such amylase that was mentioned in the paper, but not reported in detail, was from *Bacillus amyloliquefaciens* in an acetate buffer. Its half-life of 6 minutes at 70°C indicated that the acetate buffering system may allow this TTI to be developed with suitable kinetics for measuring thermal processes in the range 2 to 20 minutes at 70°C. This TTI system was chosen for estimating levels of mild pasteurisation, as encountered with short shelf-life food products. Extensive thermal evaluation was required in order that the heat stability was characterised in the range for mild pasteurisation treatments. These experiments and the data that resulted from the experiments are detailed in the following sections.

3.3 Measurement of D- and z-values for BAA70

As mentioned above, *Bacillus amyloliquefaciens* α -amylase at low concentration in an acetate buffer was the TTI system that showed the most potential for measuring P-values with mild heat treatments (Tomazic and Klibanov, 1988). As described in section 3.1, the process target was to exceed 2 minutes at 70°C, and to have a measurement range that extended upwards to around 20 minutes at 70°C. This time and temperature combination represented the lowest level of TTI heat stability described in this thesis.

The TTI for mild pasteurisation processes is referred to as BAA70 and consists of 0.5 mg/mL BAA amylase in 10 mM acetate buffer (pH 5 at 25°C). To prepare the solution, 25 mg α -amylase powder from a *Bacillus amyloliquefaciens* source (EC 3.2.1.1 Type II-A, Sigma A-6380) is dissolved in 50 mL of acetate buffer containing 1 mM calcium chloride (pH 5 at 25°C).

An amylase concentration of 0.5 mg/mL is lower than for the BAA85 or BLA90 TTIs, which are 10 mg/mL. A lower amylase concentration limits the extent which amylase solution can be diluted with buffer solution prior to conducting the assays. Typically with BAA85 and BLA90 TTIs containing higher concentrations of amylase (e.g. 10 mg/mL) the amylase solution inside the TTI tubes is diluted in a 1:30 ratio (Adams, 1996). This dilution enables several replicate assays to be conducted; which is beneficial if there are doubts with the assay result. At 0.5 mg/mL amylase concentration, the BAA70 TTI can only be diluted 1:1 with acetate buffer, which provides sufficient solution for one assay.

3.3.1 Preparation of the solutions for amylase analysis

Preparation of the acetate buffer is as follows:

- Weigh $0.036 \text{ g} \pm 0.001 \text{ g}$ calcium chloride into a 50 mL beaker. Using a measuring cylinder, add 25 mL of solution 1 and adjust pH using glacial acetic acid to pH 5.0.
- Make up to 350 mL with MilliQ water in a volumetric flask.
- Store in a fridge for up to 2 weeks

The amylase assay for BAA70 follows a similar set of instructions to those outlined in Chapter 1:

- Dilute the Amylase reagent according to instructions.
- Pipette 1 mL of the reagent solution into a cuvette.
- Extract the amylase solution from the TTI by cutting one end off the tube and use a hypodermic syringe to withdraw the entire sample. This should be at least 15 μL .
- Dilute the amylase solution with an equal volume of acetate buffer.
- Add 20 μL of the diluted amylase solution to the 1 mL cuvette containing the Amylase reagent solution and mix by inversion.
- Place the cuvette immediately into the chamber of the spectrophotometer and start logging absorbance results. The spectrophotometer should be set at 405 nm and at 30°C.

3.3.2 Kinetic evaluations of BAA70

A series of heating trials were performed to determine the kinetics of destruction of BAA70 by heat. TTIs were prepared, as described in Chapter 2, and heated in both a well stirred water bath and a circulating silicone oil bath for different combinations of times and temperatures (see Table 3.1). Immersion times were chosen to ensure that the final amylase activity was within one to two log reductions of the initial activity in order to maximise the accuracy of the measurements. These experiments were conducted separately in a Grant Instruments water bath and also in a Heto silicone oil bath. Calibrated type T thermocouples (Labfacility) connected to a Grant Squirrel 1200 series datalogger were used in the water bath, and calibrated PT1000 probes were used in the silicone oil bath.

TTI tubes were cable-tied to the thermocouples or PT1000 probes respectively to ensure that temperatures were recorded at the precise location of the TTIs. Temperature readings were taken every 30 seconds and an average bath temperature calculated from this value, having taken into account any offset in temperature from the most recent calibration data. Two or three TTIs were used with each combination of time and temperature, in addition to four unheated control TTIs for the initial activity measurement.

Table 3.1: Time and temperature combinations used to determine D- and z-values in the silicone oil and water bath.

Temperature (°C)	Water bath immersion times (minutes)	Silicone oil bath immersion times (minutes)
64	0, 5, 10, 15, 20, 25	5, 10, 15, 20, 25, 30
67	0, 5, 10, 15, 20, 25	5, 10, 15, 20, 25, 30
70	2.5, 5.0, 7.5, 10.0	2.5, 5.0, 7.5, 10.0, 12.5, 15.0
73	1, 2, 4, 6, 8	1, 2, 4, 6, 8, 10

Equation 1.6 presented the relationship between heating time (t), decimal reduction time (D_T) and the initial (N_0) and final (N) numbers of microorganisms. For the purposes of determining

the D-values at each of the heating temperatures in Table 3.1, Equation 1.6 was re-written using X_0 and X as the initial and final amylase activities respectively (see Equation 3.1). Equation 3.1 was re-arranged into Equation 3.2 to make it easier to plot all the data on one graph.

$$t = D_T \cdot \log\left(\frac{X_0}{X}\right) \quad 3.1$$

$$\log\left(\frac{X}{X_0}\right) = -\frac{t}{D_T} \quad 3.2$$

An average initial activity (X_0) was calculated from the four TTI tubes reserved for unheated controls. The gradient of a graph of $\log X/X_0$ (activity of the heated sample divided by the activity of the unheated sample) against time was used to determine the D_T -value at the four different temperatures. A graph of the $\log D_T$ -value against temperature was used to determine the z -value, which is a measure of how sensitive the D_T -value is to temperature change.

3.3.3 Results for D_{70} -value and z -value

(a) Water bath experiments

A graph of the heating time versus the logarithm of amylase activity ratio at four temperatures is shown in Figure 3.1 and the logarithm of these D_T -values at different temperatures is shown in Figure 3.2. Error bars are not shown on Figure 3.1 or 3.3 because they would clutter the data points. Errors in heating time are estimated to be of the order of ± 10 seconds, which is a measure of the time to extract the TTI tubes from the baths and quench cool them to a temperature below that at which the amylase structure breakdown occurs. In Figure 3.1, errors in temperature are estimated at $\pm 0.5^\circ\text{C}$ maximum, which contains $\pm 0.2^\circ\text{C}$ for calibration accuracy of the thermocouples and $\pm 0.3^\circ\text{C}$ for temperature distribution in the water bath.

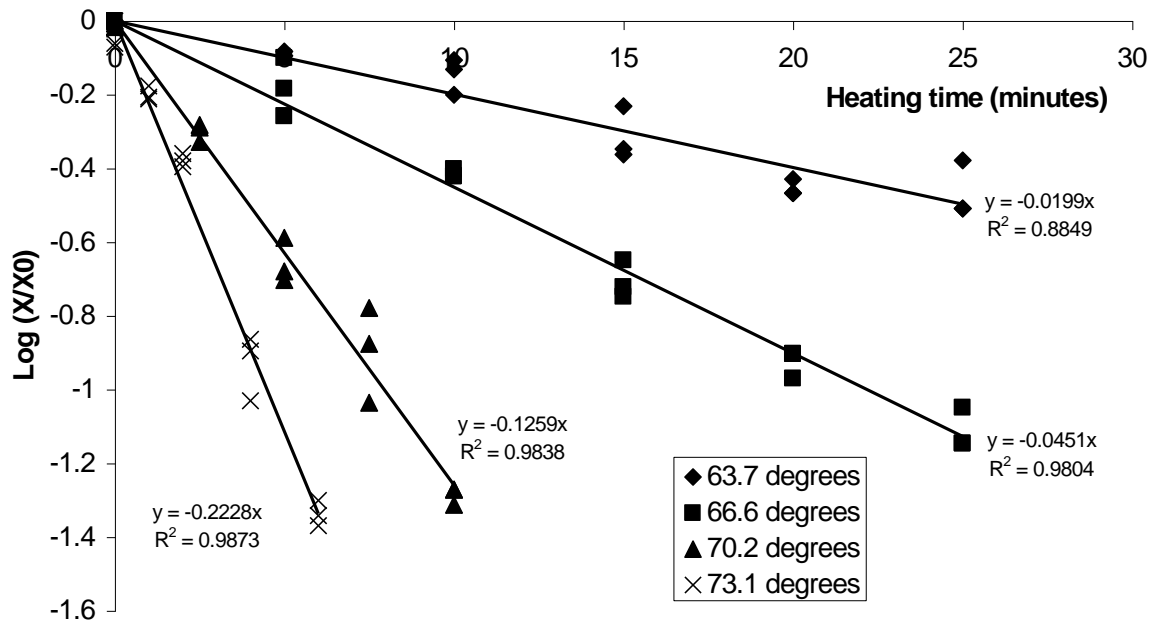

Figure 3.1: Heating time versus the logarithm of amylase activity ratio (X/X_0) for BAA70 as determined in a water bath at different temperatures from 63.7 to 73.1°C

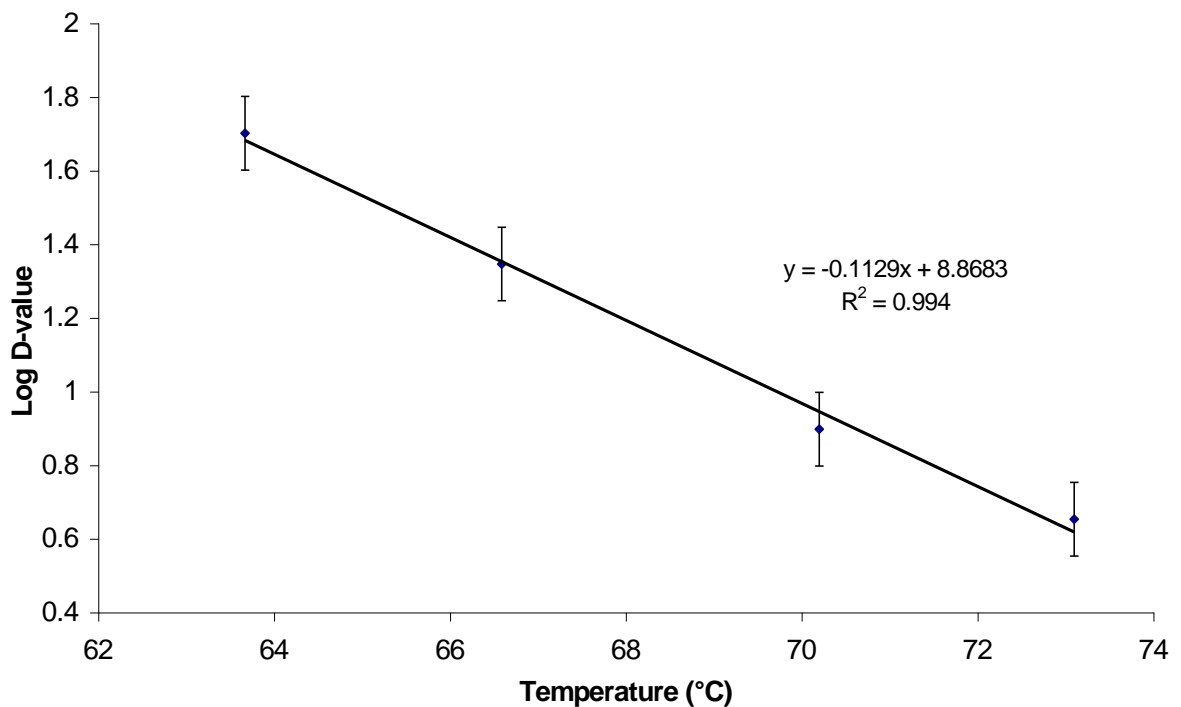

Figure 3.2: Logarithm of the D_T -values at different temperatures for BAA70 as determined in a water bath, resulting in a z-value of $8.9 \pm 0.3^\circ\text{C}$

(b) Silicone oil bath experiments

The water bath experiment was repeated in a silicone oil bath, due (a) to higher accuracy in temperature control and (b) to evaluate if there was an effect of the media on amylase activity because of concerns with moisture migration through the silicone tubing. A graph of the heating time versus the logarithm of amylase activity ratio at four temperatures is shown in Figure 3.3 and the logarithm of these D_T -values at different temperatures is shown in Figure 3.4. Errors in heating time are estimated also at ± 10 seconds, as with the water bath experiments. Errors in temperature are estimated at $\pm 0.3^\circ\text{C}$ maximum, which contains $\pm 0.1^\circ\text{C}$ for calibration accuracy of the PT1000 probes and $\pm 0.2^\circ\text{C}$ for temperature distribution in the water bath.

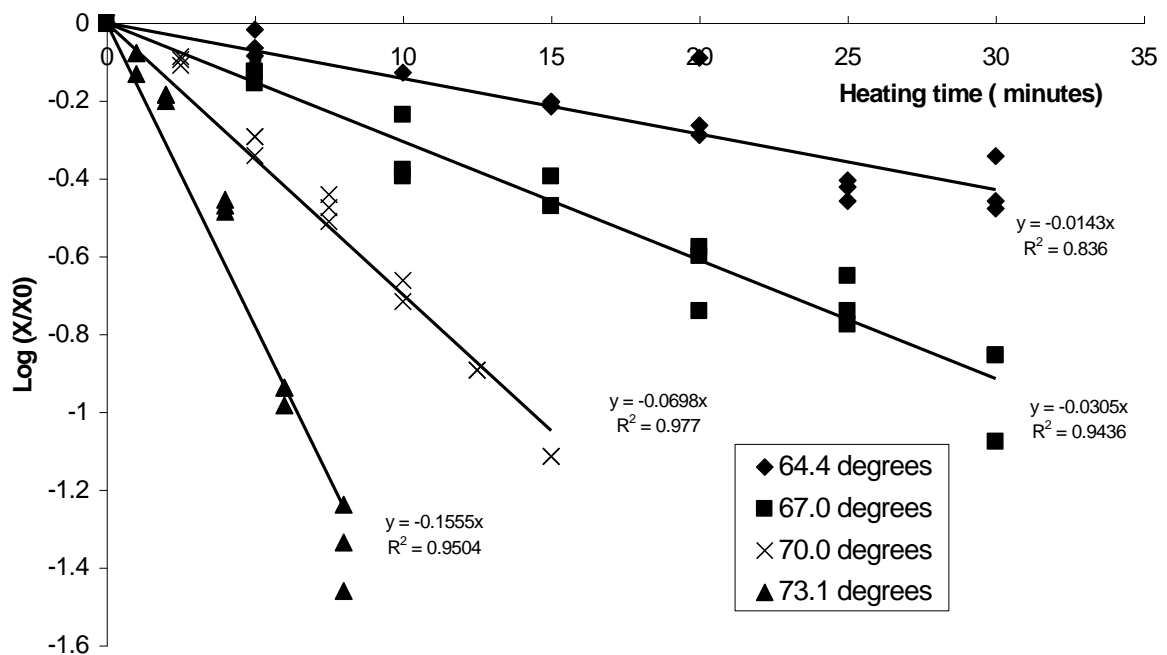

Figure 3.3: Heating time versus the logarithm of amylase activity ratio (X/X_0) for BAA70 as determined in a silicone oil bath at different temperatures from 64.4 to 73.1°C

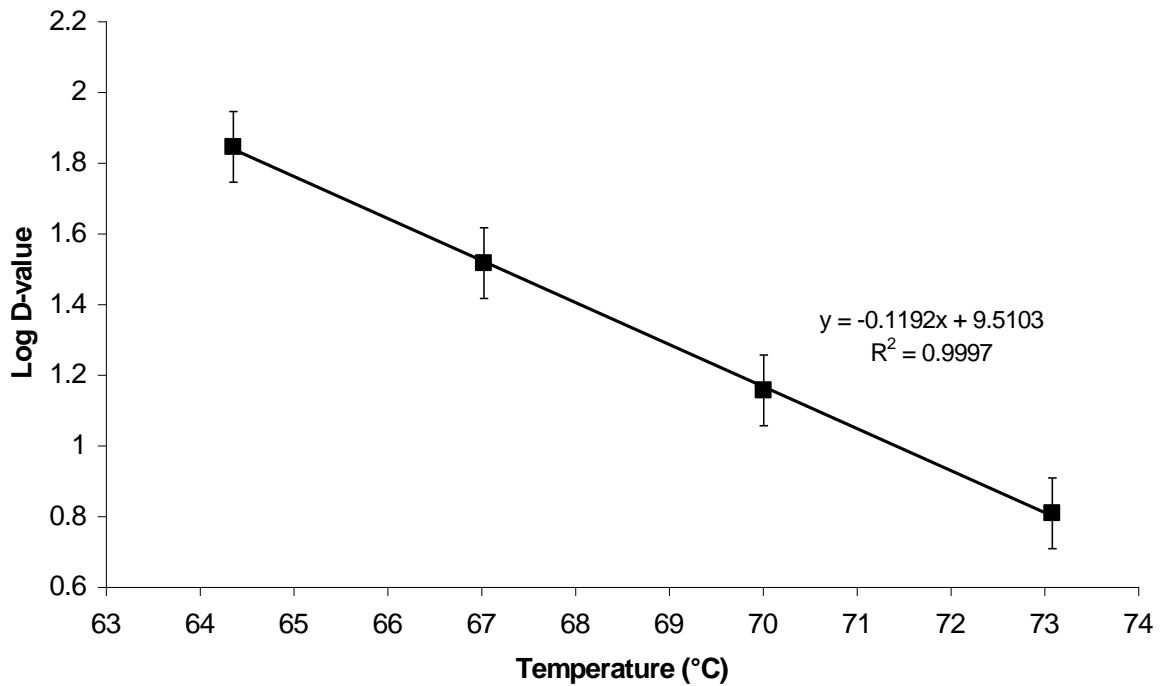

Figure 3.4: Plot of the logarithm of the D_T -values at different temperatures for BAA70 as determined in a silicone oil bath, resulting in a z-value of $8.4 \pm 0.3^\circ\text{C}$

The D_T -values and z-values measured in the water bath and silicone oil bath are summarised in Table 3.2. An estimated error in the D_T -values calculated from the gradients in Figures 3.1 and 3.3 was $\pm 10\%$, obtained from the estimated maximum and minimum gradients for each D-value gradient. This is shown on the z-value plots of Figures 3.2 and 3.4. The estimated error in z-value was $\pm 0.3^\circ\text{C}$, which was calculated from Figures 3.2 and 3.4 using the extremes of error bars on individual D-values.

Equation 3.3 was used to convert the D_T -values from the measured bath temperatures (T) to the reference temperature (T_{ref}) of 70°C . A decimal reduction time (D_{70} -value) of 8.4 minutes and a z-value of 8.9°C were calculated for BAA70 in the water bath, and a D_{70} -value of 14.4 minutes and a z-value of 8.4°C for BAA70 in the silicone oil bath.

$$D_{T_{\text{ref}}} = D_T \cdot 10^{\left(\frac{T - T_{\text{ref}}}{z}\right)} \quad 3.3$$

Table 3.2: Summary of the D_T -values obtained for BAA70 when determined in a water bath and a silicone oil bath

Test temperature (°C)	Water bath D_T -value (minutes)	Silicone oil bath D_T -value (minutes)
64	46±5	77±8
67	20±2	33±3
70	8.5±1.0	14.0±1.5
73	4.5±0.5	6.5±1.0
z-value (°C)	8.9±0.3	8.4±0.3

Higher D_T -values were obtained for experiments in the silicone oil bath in comparison with those from the water bath (D_T -values of 14.0±1.5 minutes in the silicone oil bath and 8.5±1.0 minutes in the water bath at 70°C). This was thought to be a result of the migration of small molecules through the semi-permeable silicone tubing, which could occur in several ways:

- In the water bath: Migration of water from the water bath (low concentration region) to the amylase and buffer solutions (high concentration region) within the TTI tubes will give lower concentrations of amylase in the TTI tubes. This is unlikely because of the low concentrations of amylase and buffer solutions, and the effect was not found with BAA85 and BLA90 TTIs (Tucker and Lambourne, 2001).
- In either water or silicone oil baths: Migration of small acetate molecules from the buffering solution (high concentration region) into either the water or the silicone oil (low concentration region). This is a potential concern and is investigated in a later section of this chapter regarding storage of TTI tubes in water.
- In the silicone oil bath: Migration of water, actually a drying effect, into the silicone oil. This is a likely explanation.

These effects may result in changes to the solution concentrations within the amylase TTI tubes, with possible changes to the values measured for D_T and z . However, water bath experiments are likely to be more representative of real food materials, which are typically 70-95% water. It is also important that the timescale of the heating bath measurements is similar to those used in a TTI trial with food materials. This will help to make any concentration changes reflect those that occur during the use of TTI tubes in food materials. A D-value calibration at a single temperature, for example 70°C, within the food may be worthwhile to give confidence in the method.

As a result of the greater uncertainties over molecular migration within a silicone oil bath environment, it was decided that water bath experiments should be used to obtain the D- and z-values. A calibration check using the actual food material as the heating media should be conducted wherever possible.

3.4 Spectrophotometer or colorimeter methods for the amylase assays

The method for analysis of the amylase TTIs in the above experiments is the spectrophotometer (Adams and Langley, 1998). This instrument is temperature controlled and plots a reaction rate as the amylase assay progresses towards completion. Reaction rates, or activities, calculated with the spectrophotometer have a high instrumental accuracy and are repeatable between replicate samples to within 5% (Adams, 1996).

However, there are occasions in which analysis needs to be carried out as part of an industrial trial, and to achieve this, an alternative method using a colorimeter was evaluated. The chosen instrument was a portable colorimeter. This is a more basic instrument than the spectrophotometer that has the advantage of being portable, but does not usually have temperature control. Colorimeters are used to compare the colour intensities of unknown test solutions to that of a known reference solution. The colorimeter used in these experiments was purchased from WPA Ltd (Linton, Cambridge) model CO75 with a 405nm-wavelength glass filter. This unit ran either on mains or with a battery.

The following sections describe tests done to compare the accuracy of estimated P-values calculated from BAA70 TTIs when the assays were measured with a spectrophotometer and a

colorimeter. Rates of increase of absorbance at 405 nm were measured using both a CO75 colorimeter and a Unicam spectrophotometer. To overcome the lack of temperature control with the colorimeter, assays were carried out in a temperature controlled room at 21°C. Spectrophotometer assays used a sample temperature of 30°C, as described previously, which was chosen because it was close to the optimal value for the assay (Adams, 1996).

With no temperature control in the colorimeter, sample temperature is likely to increase while the assay is active because of heat emitted from the bulb. This has the potential to change the measured rates of absorbance and so the typical straight lines from which gradients are calculated may become curved (see Figure 1.5 for an example of the reaction rate curve). This theory was tested in the following sets of experiments.

(a) Does the sample increase in temperature with sequential assays, and does this effect the calculated rates?

The first issue to resolve was whether the temperature in the measuring cell increased with long periods of use due to heat from the bulb, with a resulting increase in assay rates over time of use. An experiment was set up using the colorimeter, to perform five assays in sequence with an unheated amylase solution, and without turning off the colorimeter between assays. A stock solution of amylase was used for each assay to eliminate the chances of difference rates from samples diluted differently. Each assay took about two minutes to complete. The temperature of the Randox solution in the cuvette was taken before and after the assay was completed (see Table 3.3).

Results in Table 3.3 showed that during continuous use, the temperature of the amylase solution in the cuvette increases and this is a likely reason for a small increase in activity rate. This increase was of the order of 5-6%. Errors in the calculated rates were of the order of $\pm 10\%$.

Table 3.3: Colorimeter readings of absorbance at 405 nm from five assays performed in sequence. Minimal time delay occurred between each assay.

Time (seconds)	Absorbance readings for Sequential Assay Number				
	1	2	3	4	5
0	0.02	0.03	0.05	0.04	0.03
10	0.09	0.12	0.15	0.13	0.12
20	0.19	0.22	0.25	0.24	0.23
30	0.28	0.31	0.34	0.34	0.32
40	0.37	0.40	0.43	0.44	0.42
50	0.46	0.49	0.52	0.53	0.51
60	0.54	0.57	0.61	0.62	0.60
70	0.62	0.65	0.70	0.71	0.69
80	0.70	0.73	0.78	0.80	0.77
90	0.77	0.81	0.86	0.88	0.85
Calculated Rate	0.0087	0.0087	0.0090	0.0094	0.0092
Sample Temp (°C)	23.3	23.3	23.5	24.1	24.3

(b) Does a 2 minute break between assays maintain the sample temperature, and are the calculated rates more consistent?

The experiment was repeated, but with the colorimeter switched off in-between each assay for 2 minutes to allow the measuring cell to cool. The same stock solution of amylase was used. The results are shown in Table 3.4. Rates remained consistent for each assay, confirming the theory that the temperature in the measuring cell influenced the activity rate. Turning off the colorimeter for 2 minutes between assays resulted in consistent amylase activity readings.

Table 3.4: Colorimeter readings of absorbance at 405 nm for five assays performed with a two minute break between each one.

Time (seconds)	Absorbance readings for Sequential Assay Number				
	1	2	3	4	5
0	0.04	0.03	0.03	0.03	0.03
10	0.12	0.11	0.11	0.12	0.11
20	0.21	0.20	0.20	0.22	0.20
30	0.30	0.30	0.29	0.31	0.30
40	0.39	0.39	0.38	0.40	0.39
50	0.48	0.48	0.47	0.49	0.47
60	0.56	0.55	0.55	0.57	0.56
70	0.64	0.63	0.63	0.65	0.64
80	0.71	0.71	0.70	0.73	0.71
90	0.79	0.78	0.78	0.81	0.79
Calculated Rate	0.0090	0.00925	0.0090	0.00925	0.0090
Sample Temp (°C)	24.0	24.0	24.1	24.2	24.1

(c) Confirmation of the findings from Tables 3.3 and 3.4

The above experiments were repeated to gain confidence in the best method of measuring activity rates with the colorimeter. A fresh stock solution of amylase was made for these experiments. Table 3.5 presents these data with only the calculated rates given rather than the full time-absorbance data of Tables 3.3 and 3.4. Experiment 1 was carried out without turning the colorimeter off between assays, whereas the colorimeter was turned off for 2 minutes between assays in experiments 2 and 3. As the number of assays increased within experiment 1, so the rates increased; this was also found in the data from Table 3.3.

Table 3.5: Repeatability of colorimeter assays. Experiment 1 without turning the colorimeter off between assays. Experiments 2 and 3 with the colorimeter off for 2-minutes between assays.

Assay Sequence Number	Activity rates for each assay		
	Experiment 1	Experiment 2	Experiment 3
1	0.0076	0.0085	0.0082
2	0.0078	0.0090	0.0086
3	0.0080	0.0090	0.0090
4	0.0080	0.0094	0.0090
5	0.0084	0.0095	0.0090
6	0.0086	0.0085	0.0090
7	0.0086		
8	0.0094		
9	0.0094		

Experimental procedures were changed (improved) following the colorimeter results presented in Tables 3.3 to 3.5. When conducting assays using the colorimeter, the bulb was turned off after five assays, for at least five minutes, to allow the bulb to cool down. This was less time consuming than turning it off for two minutes after each individual assay, and it allowed the assays to be conducted with more efficiency.

Although the preference is still to conduct the assays using the temperature-controlled spectrophotometer, there are occasions when it is necessary to measure activities and calculate P-values at a factory site, so a protocol for effective use of the colorimeter is required.

3.5 Influence of different storage conditions on TTI stability

Experience with the BAA85 and BAA90 TTIs in Tris buffer showed that TTI tubes could be stored in water with minimal loss in amylase activity or detriment to the kinetic parameters

(Tucker and Wolf, 2003). Frozen storage is preferred due to the extended workable life this offers, however, chilled storage still allows several weeks. The useable shelf life of the Tris buffered TTI tubes is limited by microbial growth within the buffer from microorganisms contaminating the solutions during preparation. Tris buffer itself will last for up to four weeks when stored in the fridge (Adams, 1998). However, the BAA70 TTI uses an acetate buffer that has less inherent protection from microbiological contamination, and will only last for two weeks in a fridge (Adams, 1978). Both buffers have a tendency to go cloudy if microorganism growth gets out of control.

Storage tests were set up to determine the best method to store filled TTI tubes so that the amylase activity was not damaged. This was important for the stability of TTI tubes both before and after use in a thermal process. It is often necessary to transport TTIs to and from factory environments, sometimes in different countries. Several days, if not weeks, may expire before the amylase solutions can be extracted and the assays performed. The storage conditions tested for the TTI tubes included:

- Immersion of the TTI tubes in water or buffer solutions to evaluate whether molecular diffusion is an issue
- Storage temperatures in chilled (3 to 8°C) or frozen (-18 to -12°C) environments
- Storage times up to 56 days, with detailed testing between 0 and 14 days.

The major issues of concern were (i) the potential for water and/or small molecules to migrate through the silicone tubing and (ii) whether microbial spoilage of the amylase solution could occur. Both effects could change the kinetic properties of the amylase TTI by adjusting the concentration of amylase and buffering chemicals in the solutions. It was known that the silicone tubing was semi-permeable and allowed drying of the solution if exposed to dry air for several hours (Dow Corning, 1986). Previous TTI work had identified this as a risk (Tucker and Wolf, 2003).

Three different experiments were conducted:

- Experiment 1: The effect of storing sets of TTI tubes in water for 56 days and testing for amylase activity every 14 days:
 - Stored in the fridge¹ before processing²
 - Stored in the freezer³ before processing
 - Stored in the fridge after processing
 - Stored in the freezer after processing
- Experiment 2: The effect of storing TTI tubes for up to 14 days before use, testing for initial (unheated) amylase activity on days 0, 3, 8, 11, and 14:
 - Stored in acetate buffer in the fridge
 - Stored in acetate buffer in the freezer
 - Stored in water in the fridge
 - Stored in water in the freezer
- Experiment 3: The effect of storing TTI tubes for up to 14 days after processing, testing for final (heated) activity on days 0, 3, 7, and 14:
 - Stored in acetate buffer in the fridge
 - Stored in acetate buffer in the freezer

¹ Fridge temperature was set at 3°C but fluctuated between 2 and 5°C. Chilled conditions should reduce growth from contamination microorganisms.

² Processing refers to a constant temperature test at 70°C for 10 minutes in a well-stirred water bath, which equates to a P-value of 10 minutes. This allows approximately a one-log reduction in amylase activity, which is the region of greatest accuracy for the colorimeter assays (see results from colorimeter experiments above).

³ Freezer temperature was set at -18°C but fluctuated between -18 and -12°C. Frozen conditions should stop molecular migration and growth from contamination microorganisms, but might affect the amylase activity or the mechanisms of breakdown.

Heating tests for experiment 1 were conducted in the silicone oil bath and for experiments 2 and 3 in the water bath. Three heated TTI tubes and two unheated TTI tubes were analysed for each condition on the different days.

3.5.1 Results from Experiment 1: The effect of storing sets of TTI tubes in water for 56 days and testing for amylase activity every 14 days

Results of storage tests with TTI tubes in water before and after processing are given in Figure 3.5. Bars on the columns of Figure 3.5 represent the lowest and highest P-values obtained during the experiments. Each heating test to measure P-values used three TTI tubes immersed in a 70°C water bath for 10 minutes, therefore the P-values should equal 10 minutes. Some variation from a calculated P-value of 10 minutes was expected due to minor differences in timing of immersion and in cooling. Likely timing error with a 10 minute immersion was ± 20 seconds or $\pm 3\%$, with most of this error in the time for the TTI tubes to cool. All P-values quoted were equivalent values at 70°C.

One common finding from the data in experiments 1 and 2 were P-values of around 8 minutes instead of the expected P-values of 10 minutes. Errors in TTI results can arise from a number of sources, for example, measurement of bath temperature, concentration and dilution of the various amylase solutions, acetate buffer pH and ionic concentration, and D-value used for the calculations. Since Experiment 1 was conducted in the silicone oil bath and experiment 2 in the water bath it was unlikely that temperature measurement or applied D-value were the source of error. Differences in concentration of either the amylase or acetate buffer solutions were more likely, between those solutions used when determining the D-values (as quoted in Table 3.2) and during the tests described here. Experiment 3 used fresh samples of amylase solution and of acetate buffer.

TTIs stored in the freezer or fridge before processing gave P-values that decreased from 8.9 (day 0) to 0.4 minutes (day 56) when stored in a fridge and from 8.9 (day 0) to 2.0 minutes (day 56) when stored in a freezer.

TTIs stored in the freezer or fridge after processing were more stable, and gave P values that decreased from 8.9 (day 0) to 8.2 minutes (day 56) when stored in the fridge and from 8.9 (day 0) to 8.7 minutes (day 56) when stored in the freezer.

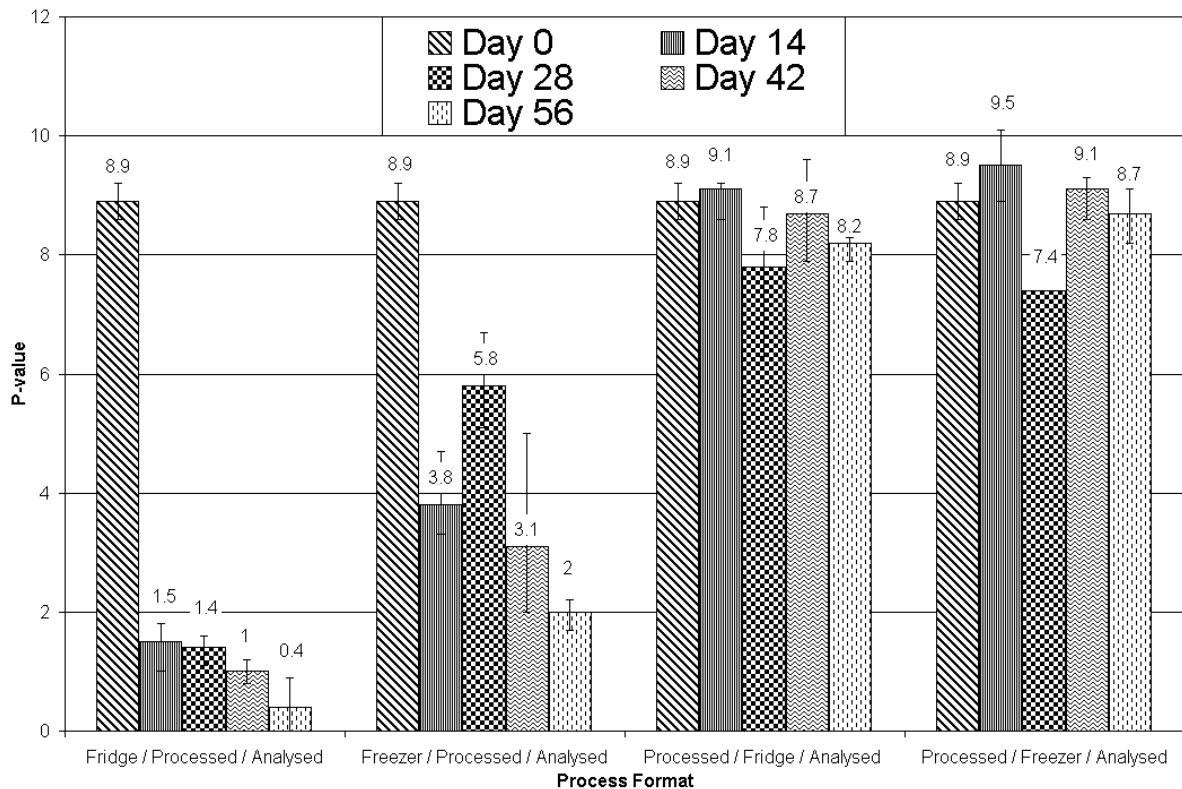

Figure 3.5: Comparison of P-values for BAA70 TTI tubes stored in water before and after processing.

The results presented in Figure 3.5 suggested that BAA70 TTI tubes should not be stored in water because the migration of small molecules such as acetate and water to and from the TTI tubes can affect the concentration of the amylase and buffer solutions.

3.5.2 Experiment 2: The effect of storing TTI tubes for up to 14 days before use, testing for initial (unheated) amylase activity on days 0, 3, 8, 11, and 14

P-value results for 10 minutes heating at 70°C are given in Figure 3.6, following storage tests in both acetate and water for TTI tubes before processing.

For the freezer tests in acetate buffer, the P-value on day 0 was 8.1 minutes and after 14 days it was 7.8 minutes. This was within the acceptable accuracy for TTI measurements of $\pm 12.5\%$ at constant temperature heating (Tucker, 1999) and $\pm 20\%$ for variable time-temperature

profiles (Bakalis, 2005; Mehauden et al., 2007). P-values were consistent for measurements taken after 0, 3, 8, 11, and 14 days of frozen storage. The range of P-values from 7.8 to 9.1 minutes was acceptable.

For the fridge tests in acetate, the P-value on day 0 was 8.1 minutes and after 14 days was 7.7 minutes. However, there was considerable variation in the P-values calculated from some of the TTI tubes after 3 days (P 4.4 minutes), 8 days (P 6.1 minutes) and 11 days (6.8 minutes).

BAA70 TTI tubes stored in water before processing, whether in the fridge or freezer, showed drastic decreases in P values. These were similar in magnitude to the values measured with the previous experiments displayed in Figure 3.5. After 3 days the P-values decreased from 8.1 to 2.5 minutes in the fridge and from 8.1 to 3.3 minutes in the freezer.

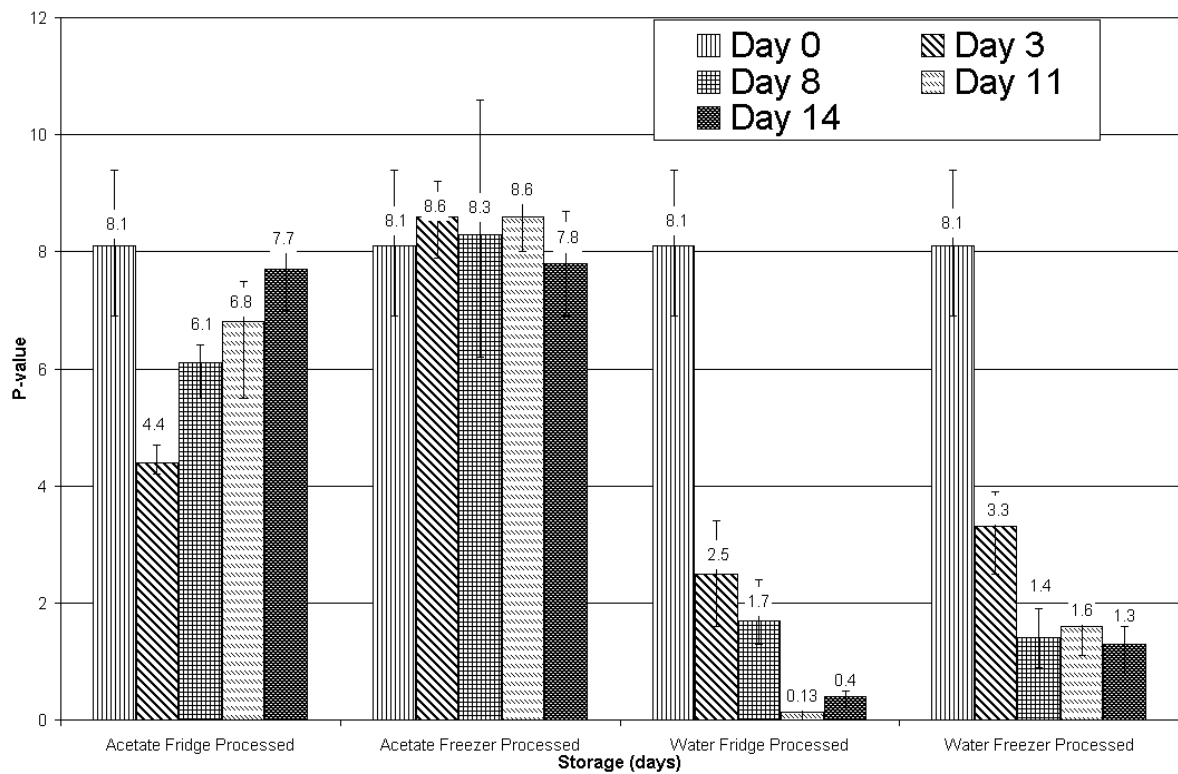

Figure 3.6: Comparison of P-values for BAA70 TTI tubes stored in water and acetate buffer, in the fridge and freezer before processing

These results suggested that the best way to store TTI tubes before processing was in acetate buffer in a frozen condition.

3.5.3 Experiment 3: The effect of storing TTI tubes for up to 14 days after processing, testing for final (heated) activity on days 0, 3, 7, and 14

The P-value results of storing TTI tubes in acetate buffer after processing for 10 minutes at 70°C are given in Figure 3.7. These showed that the TTI tubes were stable in acetate buffer over a period of 14 days. P-value on day 0 was 10.8 minutes and after 14 days storage was 10.9 minutes (in the freezer) and 9.9 minutes (in the fridge). These results suggested that storage in the freezer resulted in marginally more stable results after processing; however, the difference between 10.9 and 9.9 minutes was well within the experimental uncertainty.

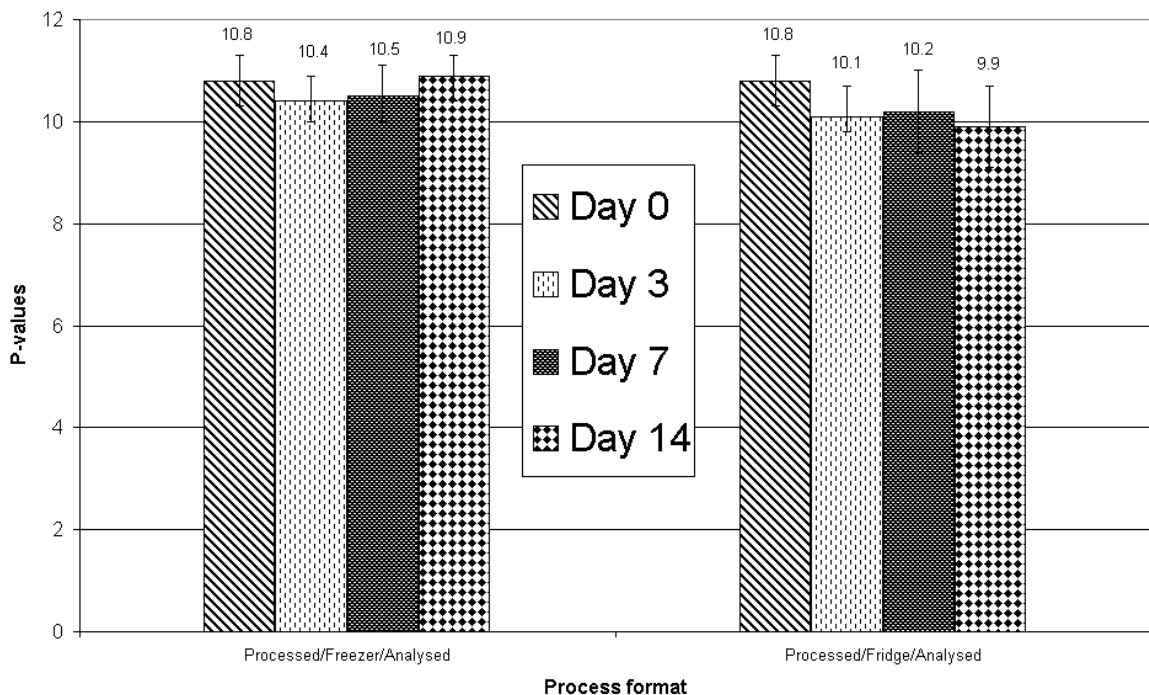

Figure 3.7: Comparison of P-values for BAA70 TTI tubes stored in acetate, in the fridge and freezer after processing

It was concluded from all three storage trials that BAA70 TTI tubes were best stored by immersing the tubes in acetate buffer. Frozen storage gave more consistent P-value results

than chilled storage; this was for amylase TTI tubes frozen before being exposed to a thermal treatment.

3.6 Industrial evaluation of the BAA70 TTI

Having completed the kinetic experiments outlined above, the BAA70 TTIs were used in four industrial trials. Each involved measurement of pasteurisation values in the headspace and/or on pack surfaces after filling of foods into containers. This is one situation where the use of wire-based probes is troublesome and TTI tubes provide a potential solution.

3.6.1 Pasteurisation of the headspace of a hot-filled soup carton

The aim of this study was to investigate the difference in P-values for a carton headspace when cartons went through either a standard hot-fill process or were inverted for two different times immediately after filling. Soup was pasteurised in a vessel using direct steam injection and a steam heated jacket; a psychrotrophic botulinum process was the target process to provide a shelf life under chilled storage in excess of 10 days (CCFRA, 1992b). This process target required the soup to be held at 90°C for at least ten minutes in the vessel. Once pasteurised, the soup was transferred to a filling vessel in readiness to be hot-filled into cartons.

Filled cartons were cooled under a water spray tunnel using a belt speed that gave a residence time of around 2 hours in total. A minimum of 70°C for 2 minutes was considered to be the safety target for the carton surfaces because of heat resistant strains of *Listeria monocytogenes* that could survive and grow in chilled products such as soups (DoH, 1989; CCFRA, 1992b).

TTI tubes were constructed as described in Chapter 2, with bore 2.0 mm and wall thickness 0.5 mm, and containing 15-20 µL of BAA70. Twenty TTIs were used in total, excluding those reserved for unheated controls. TTIs were attached with silicone sealant to the inside tops of empty gable-top cartons, using the same position in all cartons.

Various combinations of conditions were evaluated:

- Five cartons were filled with cold soup and underwent no processing. These were used as controls to ensure that the food did not interfere with the amylase kinetics,
- Five cartons were filled with hot soup at approximately 81°C and left upright for 2 minutes before the cooling tunnel,
- Five cartons were filled with hot soup at approximately 81°C and inverted for 2 minutes before being stood upright and passed through the cooling tunnel,
- Five cartons were filled with hot soup at approximately 81°C and inverted for 5 minutes before being stood upright and passed through the cooling tunnel.

Attaching the TTI tubes to the inside surfaces of pre-erected cartons proved easy. A greater difficulty was in putting the cartons back into the filler so they could be filled with hot soup. This required the filler to be stopped while unfilled cartons were removed and replaced by pre-erected cartons containing the TTI tubes. Fillers work best when the belt keeps moving and so this operation was not without carton damage; four cartons were damaged when the filler nozzle did not detect the cartons as they travelled within the filler and so the cartons were filled incorrectly. These cartons were not used for the analysis. Thus, sixteen of the twenty cartons containing a TTI tube were filled correctly.

Table 3.6 shows the P-values from the TTI tubes, calculated from the initial and final amylase activities according to Equation 1.9. Activities were measured using a colorimeter. Initial rate of amylase activity was 0.00463 s^{-1} . Average P-values (in minutes) for the three different groups of TTIs were 3.4 for the standard process, 1.9 when inverted for 2 minutes, and 6.6 when inverted for 5 minutes before cooling.

P-value results from the TTI tubes showed that not all experiments achieved a *Listeria* kill of 2 minutes at 70°C. The process where the TTIs were inverted for 5 minutes gave P-values approximately double that of the standard process without inversion. Cartons inverted for 2 minutes achieved lower P-values than the standard process; however, this may have been due

to a slightly lower fill temperature. Even a few degrees Celsius difference in fill temperature can make a big difference in P-value. For example, lethal rate calculations using Equation 2.2 show that a $\pm 0.5^{\circ}\text{C}$ change from the reference temperature of 70°C results in P-values ranging from 1.71 to 2.33 minutes, for a 2 minutes hold time.

Table 3.6: P-values for TTI tubes attached to inside surfaces of soup cartons and hot-filled with soup. D_{70} was 8.4 minutes and z was 8.9°C .

Process	Carton Number	P-value (minutes)
Standard – no inversion	1	3.2
Standard – no inversion	2	2.9
Standard – no inversion	3	2.9
Standard – no inversion	4	4.4
Invert for 2 minutes	1	0.3
Invert for 2 minutes	2	0.1
Invert for 2 minutes	3	5.0
Invert for 2 minutes	4	2.2
Invert for 5 minutes	1	7.4
Invert for 5 minutes	2	6.5
Invert for 5 minutes	3	5.8

Results from this trial showed that inversion was important in enabling the headspace and carton surfaces to achieve pasteurisation. Control of fill temperature was also critical, and probably explained why two minutes inversion did not result in P-values greater than 2 minutes at 70°C . It may not always be necessary to carry out headspace P-value work on production filling equipment. In the trials reported here, fill temperature was not controlled but instead it relied on the hot soup retaining its heat after transfer from the pasteurisation

vessel at 90°C. Experiments to evaluate filling conditions such as fill temperature and inversion times can be done in a laboratory situation where fill temperature can be controlled. TTI tubes were demonstrated as an ideal measurement system for evaluating P-values on surfaces.

3.6.2 Top-up pasteurisation requirements after filling a high acid sauce into plastic pots

The aim of this experiment was to investigate if a top-up pasteurisation process was necessary after filling and sealing of 100 g plastic pots with a high acid sauce. The present thermal process used a water spray tunnel to provide a top-up pasteurisation for the headspace and pot surfaces following a hot fill. The sauce received its pasteurisation in the cooking vessels before being transferred to the filling equipment.

A minimum of 70°C for 2 minutes was considered to be the pot surface target because of heat resistant strains of *E. coli* and *Listeria monocytogenes* (aerobic pathogens) that could survive and grow in low pH products such as these sauces (CCFRA, 1992). Two different types of TTIs were used in order to extend the TTI measurement range. BAA70 and BAA85 TTIs were prepared as described in Chapter 2 by encapsulating 20 µL of amylase inside TTI tubes. Kinetics of destruction by heat were represented by decimal reduction times (D_T value) for BAA85 at 85°C of 8.9 minutes and a z-value of 9.4°C, and for BAA70 a D_T value at 70°C of 8.4 minutes and a z-value of 8.9°C. BAA85 TTIs were kept chilled in water before and after the process, while the BAA70 TTIs were frozen in acetate buffer before and after the process.

P-values on the surfaces of small plastic pots were not easy to measure because of the low heat capacity of the 100g filled packs compared with that of datalogger systems designed to go in the packs. TTIs presented an opportunity to measure P-values without interfering with the batch-continuous process.

Combinations of hold time after filling, inversion time and cooling time are given in Table 3.7. TTIs were stuck in two positions using a silicone sealant: just below the rim (position thought to give rise in the lowest P-value) and at the bottom rim of the small 100g plastic pot. BAA70 TTI tubes were used at three different fill temperatures (75, 80 and 85°C) and BAA85

TTI tubes at only 85°C. Four different types of inversion were investigated, with all experiments done using duplicate TTI tubes.

Experience from the first BAA70 trial, reported above, suggested that control of fill temperature needed to improve. Filled pots of sauce were heated up in a water bath to simulate the different fill temperatures, so that initial sauce temperature was controlled to the values required for the experimental plan and not dictated by production conditions. When at the desired temperature, the pots of sauce were opened and the sauce decanted into the pots that already contained the TTI tubes in position. These pots were put back on the production line to be lidded.

Inversion timing started immediately after the pots were lidded. After the inversion time had expired, a bucket of cold water was used to cool the pots in a similar way to the continuous spray cooler. Total cooling time was 7 minutes, resulting in cooling for 5 minutes for all the pots, except for the BAA85 TTI at 85°C, which received a cooling time of 3 minutes. The pots were opened when cooled below approximately 50°C and the TTIs removed.

Table 3.7: Combinations of variables used in setting up the experiment to evaluate headspace and surface pasteurisation

	BAA70 TTI			BAA85 TTI
	75°C fill	80°C fill	85°C fill	85°C fill
Fill, hold 0 s Invert, hold 120 s	75/0	80/0	85/0	85/0
Fill, hold 30 s Invert, hold 90 s	75/30	80/30	85/30	85/30
Fill, hold 60s Invert, hold 60 s	75/60	80/60	85/60	85/60
Fill, hold 120 s Invert, hold 120 s	75/120	80/120	85/120	85/120

P-values measured from the TTI tubes are given in Table 3.8. BAA70 TTIs in pots filled at 75°C showed almost no change in activity in the amylase, resulting in all P-values less than 1.1 minutes. For a 75°C fill, the different inversion processes had minimal effect on the P-values. P-value results for the BAA70 TTIs in pots filled at 80°C showed the same pattern, with the highest P-value of 0.7 minutes, but most TTIs showed no measurable change in activity. BAA70 TTIs in pots filled at 85°C showed higher P-values on average, with a maximum value of 3.3 minutes. BAA85 TTIs filled at 85°C showed very similar results when the P-values were converted to a reference temperature of 70°C, with little change in amylase activity.

Table 3.8: P-values obtained from the TTI trials to evaluate different fill temperatures and inversion times for a 100g pot of hot filled sauce

values from Masterfoods Dolmio Sauce

	Hold 0mins, invert 2mins, 5mins cooling		Hold 30secs, invert 90secs, 5mins cooling		Hold 1mins, invert 1mins, 5mins cooling		Hold 2mins, invert 2mins, 3mins cooling	
	Top	Bottom	Top	Bottom	Top	Bottom	Top	Bottom
BAA70 Fill at 75°C								
Sample 1	0.0	0.0	0.0	1.1	0.0	0.0	0.0	0.2
Sample 2	0.3	0.0	0.0	0.3	0.0	0.6	0.0	0.0
BAA70 Fill at 80°C								
Sample 1	0.0	0.5	0.0	0.2	0.0	0.0	0.4	0.7
Sample 2	0.0	0.0	0.0	-	0.7	0.1	0.4	0.0
BAA70 Fill at 85°C								
Sample 1	0.7	1.9	0.1	1.2	1.0	0.1	1.3	1.2
Sample 2	0.8	-	0.0	1.8	2.2	0.0	1.4	3.3
BAA85 Fill at 85°C								
Sample 1	0.0	0.0	0.0	0.0	0.2	0.0	0.0	3.8
Sample 2	1.5	0.3	0.0	0.0	-	-	0.0	-

An explanation for these low P-value results may relate to the small volume of sauce in the 100 g pot when compared with the large surface area (pot diameter is 10 cm). This is likely to cause the sauce surface to cool quickly. The heat capacity of the sauce is not sufficient to maintain the high sauce temperature for long enough to pasteurise the lidding material.

These results suggested that a fill temperature higher than 85°C was required to obtain P-values sufficient to avoid the need for a top-up pasteurisation. It may not be possible for the sauce in this small pot to contain sufficient heat to pasteurise the surfaces without a top-up pasteurisation if the present fill temperatures are maintained.

Working with controlled fill temperature and inversion conditions made this TTI trial easier to manage than the previous one in a production filling environment. Results for P-values were equally valid and gave clear indication of what the company needed to do to pasteurise the pot lidding material.

3.6.3 Headspace pasteurisation in mini jam jars

Mini jam jars (15g) are used for food service applications, for example in motorway service stations and hotels. Issues have arisen in commercial practice whereby surface spoilage of the jam had occurred and so a TTI trial was set up to find out whether low cap surface P-values were the reason. Heat capacity concerns with the jam and the glass containers were suspected of causing low surface temperatures that allowed sporadic outbreaks of spoilage.

The aim of this experiment was to evaluate the surface pasteurisation process following hot-filling and capping, by measuring P-values in the headspace of small glass jars.

Thermocouples could not be used and so TTIs provided the opportunity to measure P-values without interfering with the capping equipment. A minimum of 70°C for 2.1 minutes was considered to be the safety target to achieve a minimum of six log-reductions in the ascospores of heat resistant ascospores of *Saccharomyces cerevisiae* yeast (CCFRA, 2006). This microorganism can thrive in high acid foods, particularly fruit products such as jams.

Thirty TTIs were used on strawberry mini jam jars. TTIs were prepared by encapsulating 20 µL of BAA70 inside TTI tubes, as described in Chapter 2. TTI tubes were positioned in the following locations:

- Ten TTIs were attached to the underside of the caps of ten jars using silicone sealant
- Ten TTIs were placed in the bottom of the jars
- Five TTIs were floated on the jam surface after filling

- Five TTIs were stuck to the inside rim of the jar so they were half in the jam

The jam temperature in the preparation vessel before filling was 78.7°C on the day of the trials, but since it was filled into unheated jars there was potential for it to drop quickly. The jars containing TTIs were filled and capped under production conditions. These included a short raining water section immediately post-capping followed by cooling in cold raining water, and drying with air jets. Temperature of the raining water was set at 70°C with a duration in which the jars were enclosed by the water of less than one minute.

TTI tubes analysed from the bottom of the mini jars showed that no measurable P-value was achieved. It was likely that this was due to the jam being filled into cold jars, which was a situation that occurred on occasion, particularly in the mornings during winter. TTI tubes stuck to the underside of the caps showed low P-values, although still less than 2.1 minutes at 70°C. This was a slightly increased level from the TTIs at the jar bottom, and likely to have been a result of the high temperature of the raining water on the jars after capping. TTI tubes floated on the jam surface and stuck around the rim of the jar showed low P-values. Table 3.9 presents the P-values from all of the locations.

These low P-value results explained why sporadic issues can occur with moulds on the product surfaces. P-values from the TTI tubes were lower than the target process of 2.1 minutes at 70°C and therefore there will be survival of yeast and mould ascospores on occasion. This occurred for similar reasons to those for the high acid sauce hot-filled into plastic pots, in that there was insufficient heat capacity within the product to effect a pasteurisation of the surfaces.

This TTI trial proved successful and easy to implement; with all of the TTIs stuck with sealant to the lids or floated on the jam surface remaining in position. P-value results showed clear reasons why sporadic mould occurred on the jam surfaces.

Table 3.9: P-values obtained from the headspace and surfaces of mini jam jars when hot-filled with strawberry jam at 78.7°C

Process	Jar No.	P-value (minutes)		Process	Jar No.	P-value (minutes)
Bottom of the jar	1	0.0		Underside of the cap	1	0.6
Bottom of the jar	2	0.0		Underside of the cap	2	0.3
Bottom of the jar	3	0.0		Underside of the cap	3	1.3
Bottom of the jar	4	0.0		Underside of the cap	4	1.5
Bottom of the jar	5	0.0		Underside of the cap	5	1.6
Bottom of the jar	6	0.0		Underside of the cap	6	1.2
Bottom of the jar	7	0.0		Underside of the cap	7	1.3
Bottom of the jar	8	0.0		Underside of the cap	8	1.6
Bottom of the jar	9	0.0		Underside of the cap	9	0.3
Bottom of the jar	10	0.0		Underside of the cap	10	1.3
Rim of the jar	1	0.3		Surface of the jam	1	1.3
Rim of the jar	2	0.1		Surface of the jam	2	0.4
Rim of the jar	3	0.3		Surface of the jam	3	0.0
Rim of the jar	4	0.0		Surface of the jam	4	0.9
Rim of the jar	5	0.1		Surface of the jam	5	0.4

It is suggested that to prevent mould issues, a number of options were available:

- Cold jars could be heated before filling, as part of the water washing stage, so the temperature loss in the jam was reduced
- Jam could be hot-filled at a higher temperature, although this would take longer to heat up and might cause quality problems
- A top-up pasteurisation tunnel using raining water between 70 and 75°C could be used

3.6.4 Pasteurisation in baked mushroom quiches

Taking temperature measurements in a product that changes phase from liquid to solid during cooking is a difficult task. This is exacerbated if the process involves a continuous cooking operation. Ready-to-eat quiches are now a popular cooked product sold in chilled cabinets with short shelf lives. They are made with liquid egg fillings in an open pastry case, in which the egg proteins set during the process and in doing so cause a change of phase from liquid to solid. Positioning temperature probes in the centre of the fillings and holding them in place as the quiche travels along the belt of a continuous oven is not possible. Small TTI tubes, however, can be placed in the pastry base and will stay in the correct position throughout the process. This method was used to assess the safety of a new quiche product.

For egg products, there is a risk of *Salmonella* survival through the thermal process and subsequent growth during the shelf life, and so the target process is to exceed 70°C for 2 minutes (CCFRA, 1992).

The aim of this TTI trial was to measure P-values with the BAA70 TTIs for this complex product. Twenty BAA70 TTI tubes were used in ten mushroom quiches, two per quiche. In each quiche, one TTI was placed in the centre of the uncooked quiche and one TTI at the edge. The quiches were put on mesh trays onto the belt of a continuous oven set at 210°C, and the quiches were in the oven for approximately 25 minutes. Once cooked, the quiches passed through a cooling tunnel for 10 minutes before the trays were removed by hand and placed in a blast chiller for 25 minutes. The TTI tubes were removed from the quiches at approximately 26°C when they were cool enough to handle.

Table 3.10 presents the P-values calculated from the TTIs. All of the cooked quiches containing TTIs received sufficient pasteurisation to exceed 70°C for 2 minutes. The centres of the quiches had P-values slightly lower than at the edge, which was not surprising because the centre was the expected cold spot.

Table 3.10: P-values measured in the centre and edge of mushroom quiches.

D₇₀ was 8.4 minutes and z was 8.9°C.

Quiche Number	Position	P-value (minutes)	Position	P-value (minutes)
1	Centre	4.9	Edge	13.9
2	Centre	9.8	Edge	13.9
3	Centre	12.8	Edge	15.4
4	Centre	10.3	Edge	14.5
5	Centre	11.1	Edge	13.9
6	Centre	10.5	Edge	13.6
7	Centre	16.7	Edge	16.5
8	Centre	13.2	Edge	18.7
9	Centre	16.7	Edge	13.8
10	Centre	16.7	Edge	12.6

P-value results from the quiches were all greater than the target of 2 minutes at 70°C, which confirmed that the oven process was adequate. The most challenging part of this continuous oven trial was to find the quiches in which the TTI tubes were placed. This was achieved by sectioning a small quantity of quiches on wire mesh racks that travelled through the oven together. Quiche packing density was kept the same as with the rest of the batch otherwise there might have been questions about the heat transfer conditions.

3.7 Conclusions from mild pasteurisation BAA70 TTI trials

BAA70 at 0.5 mg/mL in acetate buffer provided at TTI system that was ideal for measuring P-values with mild pasteurisation processes. A D₇₀-value of 8.4 minutes and a z-value of 8.9°C were calculated from the kinetic experiments in the water bath. Slightly different values were calculated from silicone oil experiments and this was thought to be due to water or acetate migration through the tubing walls. This was an interesting finding that had

implications for handling and storage of the other TTI systems based on Tris buffer. D-value results from the water bath were used because they represented a medium similar to an actual food product containing a high percentage of water.

The upper limit of P-values that could be measured with the BAA70 TTI depended on the sensitivity of the amylase assay method. It was possible to measure P-values up to 16 minutes at 70°C if a colorimeter was used for the assays, and up to 25 minutes at 70°C if a spectrophotometer was used. Most heat treatments for products that were appropriate for testing with the BAA70 TTI used a minimum process of 70°C for 2 minutes, but actually achieved much more than this. Typical processes were often 6-10 minutes at 70°C, which enabled the BAA70 TTI to be operated within the middle of its range, and therefore at the highest accuracy levels.

Chilled storage of TTIs for up to 14 days was found acceptable but longer storage time enabled microbial growth to occur in the acetate buffer. Storage experiments showed that the BAA70 TTI tubes were best stored in the freezer for longest shelf life. This was found to be suitable for either the unprocessed or processed TTI tubes. This information suggested that frozen TTI tubes could be transported to and from the site of an industrial trial without either (i) the concern of amylase breakdown or (ii) microorganism growth in the buffer solutions. This finding was invaluable for enhancing the merit of TTIs as a method for validating process values in food manufacturing operations.

Storage of filled TTI tubes in acetate buffer was essential for BAA70 TTIs in order to prevent molecular migration through the silicone tubing. This result was also applied to the Tris buffered TTIs so that consistency was assured when using a TTI to measure an industrial process value.

Results obtained from industry trials showed that the BAA70 TTI could be used with great success to evaluate headspace and surface pasteurisation in various containers and products. The TTI method is one that a company could adopt easily for QA/QC checks, which are common practice with short shelf life food products (DoH, 1989). BAA70 TTI tubes can be frozen in small numbers, for example 5-10 tubes, sufficient for such a P-value check. Analysis of the amylase activity can be carried with a colorimeter on site or sent back to a laboratory for the spectrophotometer assay to be done.

CHAPTER 4: CASE STUDIES OF TTI APPLICATIONS TO FOOD PROCESSES

‘Anyone who has never made a mistake has never tried anything new’

Albert Einstein

Previous experimental work in this thesis has described TTIs that have been used in relatively simple batch processes, such as the measurement of pasteurisation at the surfaces of food packaging or in the centre of a food product. Here the work is extended to more complex processes in which the food or the package ‘flows’ during its thermal treatment. Measurement of pasteurisation values (P-values) for flowing foods demands TTIs that can move with the food or package without interference with the process or measurements.

The objectives of the work reported in this chapter were to develop and apply the amylase TTIs (as described in Chapter 2) to estimate P-values achieved at the centre of moving fruit pieces. A temperature sensor is the easiest method by which a P-value calculation can be undertaken, however, in each of the case studies described here the use of temperature measurements were not possible. Each of the different types of processes presented its own challenges for the methods that can be used to obtain validation data. These comprised semi-batch processes in which fruit products were either (i) heated in a batch vessel and cooled in a heat exchanger, or (ii) heated in a continuous flow system and cooled in the packs. The trials also included fully continuous flow processes in which both heating and cooling were achieved using heat exchangers. Some of the challenges facing the TTI applications are described.

1. Fruit pasteurised in a mixing vessel requires agitation to ensure the fruit makes good contact with the heated surfaces. Fruit particles follow undefined pathways within the vessel and so any measurement must be self-contained within a particle. Monitoring of the batch temperature can only be achieved using a hand held probe dipped into the fruit, with the agitator off, and moved around until the lowest temperature is measured. Very large

temperature differences (up to 30°C) can be measured within these types of vessels if the product viscosity is high.

2. A tubular heat exchanger contains many tubes in series that raise the liquid to a set temperature, which is followed by a 'constant' temperature holding section. Food safety measurements assume that the thermal treatment of a product occurs within this holding tube (CCFRA, 1986 and 2007). Monitoring of the product temperature is achieved with a temperature probe at the holding tube exit. It is assumed that under laminar flow conditions the fastest moving particle can travel at twice the average speed, and so the hold tube length needs to be doubled (from that calculated with the flowrate and tube diameter).
3. An ohmic column works in a similar way to a tubular heat exchanger except that the heating tube contains a number of electrodes to raise the product temperature by the passage of electric current. Ohmic heating is a relatively new technology described later in this chapter (section 4.5). Monitoring of the product temperature is achieved with a temperature probe at the holding tube entrance because the particles release their energy to the liquid along the holding tube and so the exit temperature is nearly always higher than the entrance. The same assumptions are applied for laminar flow and so the calculated hold tube length is doubled.
4. In a hot-filled Pergal bag, heat from the product must be sufficient to pasteurise the inside bag surfaces. Access with temperature probes to the inside is not permitted and so a self-contained measurement device attached to the surfaces must be used. This is further complicated by the long distances required to move a rack of Pergal bags from the filling room to the chilled stores and then into despatch when cooled.

4.1 Calculation of P-values with TTIs

P-values estimated with TTIs are calculated from the initial and final amylase activities using Equation 4.1. These activities are measured from amylase solutions extracted from the TTIs, which are diluted with buffer solution and assayed using an amylase reagent such as that from Randox. Chapter 3 details the various assay procedures.

$$P = D_T \cdot \log\left(\frac{A_{initial}}{A_{final}}\right) \quad 4.1$$

where, A_{final} is the final amylase activity after a specific time-temperature history, s^{-1}

$A_{initial}$ is the initial amylase activity, s^{-1}

D_T is the amylase decimal reduction time at the reference temperature (T), minutes

However, if a P-value is calculated from temperature measurements, the z-value is used in the calculation (Bigelow et al., 1920). In order that an amylase TTI system can be applied to estimate microbiological log reductions, it is essential that the z-value for microbiological destruction and for amylase structure breakdown are similar. Equation 4.2 presents the lethal rate equation used to calculate a P-value, which integrates the time and temperature effect of a thermal process.

$$P = \int_0^t 10^{\frac{T(t)-T_{ref}}{z}} \cdot dt \quad 4.2$$

where, T_{ref} is the reference temperature that must be the same as that used in calculating the

D_T -value in Equation 4.1, °C

$T(t)$ is the food product temperature that changes with time (t), °C

z is the kinetic factor, °C

P-values calculated with Equations 4.1 and 4.2 will be the same providing that first order death kinetics are appropriate to both microbiological and amylase breakdown by heat, and specifically both systems are typified by the same z-value.

4.1.1 Microbiological process targets

All of the fruit products used for the case studies presented here contained fruit acids, which made them inherently acidic. Microorganism such as mesophilic strains of *C. botulinum* are unable to grow below pH values of 4.5 (DoH, 1994) or 4.6 (Stumbo, 1965). Of concern for the shelf stability for fruit products are yeast and moulds that are able to thrive in acidic

conditions. Some of these can produce heat resistance ascospores that are produced as part of the growth cycle but intended to enable the fungi to survive more hostile conditions. Yeast ascospores are the target microbial species for fruit products with pH values below 3.7.

A typical thermal process sufficient to reduce the ascospore numbers by six log reductions is 10 minutes at 85°C (CCFRA, 1992). This was the target process used for all of the fruit case studies. It is generally accepted that a six log reduction in microorganisms is acceptable for a pasteurisation process because of the presence of a hurdle to preventing growth of microorganisms. In these fruit products is the high acid conditions that prevent any surviving ascospores from germinating. Equation 4.3 illustrates how the P-value target is calculated.

$$P = D_T \cdot \log \left(\frac{N_{initial}}{N_{final}} \right) \quad 4.3$$

where, N_{final} is the final number of microorganisms after a specific time-temperature history
 $N_{initial}$ is the initial number of microorganisms
 D_T is the microorganism decimal reduction time at the reference temperature (T),
minutes

Equations 4.1, 4.2 and 4.3 should provide the same calculated P-value providing that the D_T -values for both amylase and microorganism are quoted at the reference temperature (T_{ref}) and the z-value for both amylase and microorganism are the same.

4.2 Experimental TTI trials on fruit products

Eight pieces of work are discussed in detail to describe the development and application of the TTI method. These took place in sequence over a period of 36 months, using the processing facilities at Kerry Aptunion (Fruit Preparations) in Okehampton for each trial. Significant TTI method development occurred during this sequence of trials. Each trial presented its own set of difficulties.

The first three trials worked with batch mixing vessels and were responsible for improving the techniques described in Chapter 2 for making TTI particles with sufficient strength to survive high shear processes. These trials were:

1. 400 kg batch of diced strawberries processed in a 1,000 kg stirred vessel
2. 500 and 430 kg batches of pineapple & passion fruit processed in a 1,000 kg stirred vessel
3. 325 kg batch of apricot processed in a 1,000 kg stirred vessel

The next five trials worked with continuous heating processes, which required the TTI particle densities to match closely those of the fruit particles. Methods for obtaining correct TTI particle densities are also described in Chapter 2. Improvements in techniques for recovering TTI particles from continuous processes were also investigated. These trials were:

4. 1,000 kg batch of pear & toffee processed in a 22 diameter tubular heat exchanger
5. 250 kg batch of whole strawberries processed in a 75 kW ohmic column
6. 850 kg batch of blackcurrants and 790 kg of diced pineapple processed in a 75 kW ohmic column.
7. 400 kg batch of diced strawberries processed in a 75 kW ohmic column.
8. Two 850 kg batches of nectarine & orange processed in a 75 kW ohmic column, hot-filled into 8.5 kg plastic bags

First attempts at incorporating TTI particles into a food process, as described in case 1, resulted in about 25% of TTI particle break up and about 75% recovery of TTIs at the end of the thermal processing step. By the end of the last trials, as described in case 8, TTI break up was 0% and recovery at 100% or very close to it (but always with a reason if <100%).

Individual findings are described with each case study to build up an evolution sequence for the improvements of TTI applications. Table 4.1 presents an overview of the key experimental criteria for each of these trials.

Table 4.1: Experimental details for the eight fruit product trials. Key to fruit descriptions: DS = Diced Strawberry, P&P = Pineapple and Passion Fruit, A = Apricot, P&T = Pear and Toffee, WS = Whole Strawberries, B = Blackcurrants, DP = Diced Pineapple, N&O = Nectarine and Orange. Tube* means the TTI tube was inserted directly into a whole strawberry.

Trial number	1	2		3	4	5	6		7	8
Fruit description	DS	P&P	P&P	A	P&T	WS	B	DP	DS	N&O
Heating type	vessel	vessel	vessel	vessel	T.H.E	ohmic	ohmic	ohmic	ohmic	ohmic
Batch weight (kg)	400	500	430	325	1,000	250	700	650	400	850
Product pH	3.3- 3.8	3.2- 3.5	3.2- 3.5	3.3- 3.8	<3.8	3.3- 3.8	<3.8	<3.8	3.3- 3.8	3.5
Fruit particle size (mm)	12	12	12	17	12	-	10	12	12	12
TTI particle size (mm)	10	10	10	14	10	-	8	10	10	10
TTI geometry	cube	cube	cube	cube	cube	tube*	sphere	cube	cube	cube
Number of TTIs used	12	75	45	45	70	15	44	43	110	60
Number of TTIs recovered	10	71	45	43	69	13	29	43	110	59
Number of P-values measured	10	21	45	43	69	12	29	43	110	59

All of the food processes described in the following sections contained batch-continuous components that hitherto created experimental difficulties in measuring fruit particle P-values. Thus, most of these fruit processes in a mixing vessel or flow system could not be measured with wire-based systems such as thermocouples or even with self-contained dataloggers. Prior

to the use of TTIs to measure P-values for the processes, the process values were achieved using temperature sensors that measured the liquid temperature surrounding the fruit particles. So that food safety was assured, hold times at these temperatures were deliberately extended to 90°C for 5 minutes to account for thermal conduction into the food particles. This resulted in fruit products that were thermally processed for longer than was required.

TTI data that represented the pasteurisation given to the core of the food particles provided invaluable data for measuring the achieved P-values and for conducting process optimisation studies.

4.2.1 Description of the types of processes

All of the fruit processes described in this chapter contained three common parts:

- a batch mixing vessel where the ‘raw’ ingredients were prepared before they were ready for transfer via a positive displacement pump to the thermal processing step,
- either heated in the batch mixing vessel or in a continuous flow system,
- a filling system using either a stainless steel tanks or a plastic bags to contain the cooled fruit.

P-value results that were representative of the fruit pieces had to be taken correctly, otherwise incorrect conclusions could be drawn on the microbiological condition of the processed fruit. Each part of the process system contained its own sets of challenges for the TTI methods, as described in the subsequent sections.

4.2.2 Introducing TTI particles into batch mixing vessels

The first challenge was to introduce the TTI particles into the fruit products so that they were distributed evenly throughout the batch. This was important because of the differences in fruit temperature within the vessel, depending on its relative position to the heated surfaces. By achieving a random distribution of TTI particles in the batch it would be expected that the distribution of P-values from the TTIs would be representative of that in the actual fruit pieces.

Figures 4.1 and 4.2 illustrate the system, common to all of the fruit trials, that was used in the mixing vessels for preparing the ingredients and introducing the TTI particles to the mixture. The 1,000 kg cylindrical vessels (see Figure 4.1) contained a hemispherical base with horizontal scraped surface agitation. TTI particles were added to the fruit product in the vessels at the stage when the mixing was at its most vigorous (see Figure 4.2). This ensured the TTI particles were distributed evenly in the batch. Figure 4.2 shows the surface of an apricot mixture showing high agitation, at the time when the TTI particles were added; this occurred when the fruit level was below the central agitator shaft. This mixture preparation method was also used for the tubular heat exchanger trials in which the TTI particles were required to enter the exchanger randomly and, in doing so, experience the range of minor time-temperature fluctuations that is natural for continuous flow systems.

A different system was employed with the ohmic heater trials because of the need to investigate a number of process conditions with one fruit batch. Typical factory settings used the 75 kW ohmic heater at a throughput of $750 \text{ kg}\cdot\text{h}^{-1}$. Process optimisation work on the ohmic heater required TTI particles to be introduced to the same fruit mixture in four batches. Pump throughput and current settings on the ohmic column were both changed for each TTI batch so that more than one column operating condition could be tested with one batch of fruit mixture. Distributing the TTI particles evenly in the feed tank was not an option because the TTIs would enter the ohmic column randomly. A random distribution gave no control over how many TTI particles passed through the ohmic heater at each flowrate set-point. Instead, the TTI particles were dosed directly into the vessel outlet, immediately prior to the stage at which the piston pump drew product from the vessel. This was achieved using a 2" diameter dosing tube pushed to the tank outlet and the TTI particles were pushed into the outlet using a closely fitting inner tube. This ensured that a group of marked TTI particles entered the ohmic heater at approximately the same time and thus experienced the same process conditions. Details of the ohmic heating system are described in section 4.5.



Figure 4.1: 1,000 kg vessel being filled with an apricot product. TTI particles were added after the fruit was in the vessel.



Figure 4.2: Apricot fruit product in the vessel with scraped surface agitator switched on. TTI particles were introduced at this stage by dropping them into the batch.

4.2.3 Ensuring streamline flow of TTI particles in continuous heating systems

In this part of the fruit processes there was no control over the position of the TTIs within the heating, holding and cooling tubes. Relative buoyancy of the TTIs and fruit pieces was the controlling factor, but with the assistance of a high carrier liquid viscosity to maintain the TTIs in position (i.e. one in which the relative velocity of the two phases was minimised). Considerable effort was taken to construct TTI particles with similar densities to the fruit pieces which they were intended to represent. Chapter 2 described the methods used to make the TTI particles. Most of the fruit pieces reported in this chapter were some 15-30% less dense than the carrier liquids because of the relative sugar content of the liquid. Figure 4.3 illustrates some examples of TTI particles used to represent fruit pieces in these experiments.

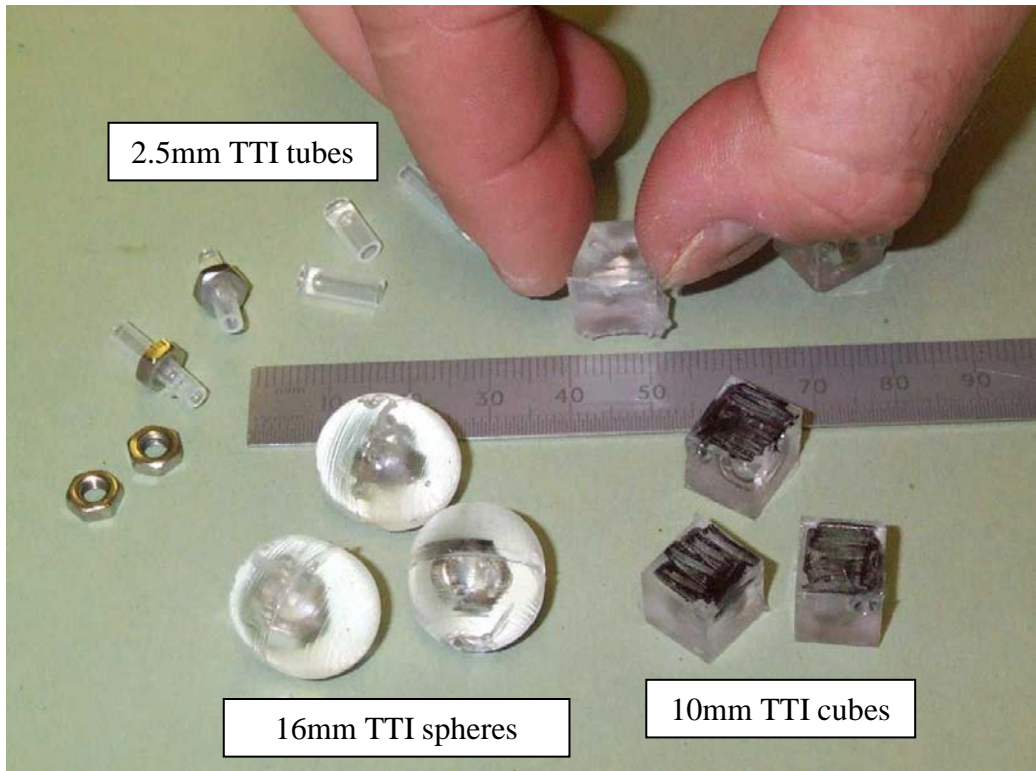

Figure 4.3: Examples of TTI tubes and particles. 10 mm cubes were used in several experiments. Ferrous nuts were included as a method to reject TTIs using metal detectors.

Thermal and physical property calculations for fruit pieces showed that Sylgard 184 elastomer was the material most suited for TTI particle construction. Sylgard 184 density was $1,050 \text{ kg.m}^{-3}$ (Dow Corning data sheet, 1986) which was close to that of the fruit pieces. Sylgard 184 thermal diffusivity was calculated using heating factor (f_h) experiments with large blocks of the elastomer and found to be $1.02 \times 10^{-7} \text{ m}^2.\text{s}^{-1}$ at 20°C (McKenna and Tucker, 1992). The method for measuring heating factors and converting the data to thermal diffusivities followed that given in Chapter 2, in which Equations 2.10 and 2.11 were used for the conversions. Thermal diffusivity values for Sylgard 184 were similar to those for fruit, which were 1.3 to $1.4 \times 10^{-7} \text{ m}^2.\text{s}^{-1}$ at 20°C , taken from measurements with a line source heat probe and from literature sources such as George (1990).

Equivalent thermal pathway calculations, also using the f_h approach of Equations 2.10 and 2.11, suggested that TTI particles should be 20-30% smaller than the fruit pieces they were intended to represent. This was considered to be sufficiently close so that concerns over differences in heat transfer coefficients from fluid to particle (h_{fp}), and in flow pathways were minimised. Previous work by Tucker (1999a) had demonstrated that a Sylgard 184 particle and a carrot cube (of similar physical size) travelled at similar velocities down a transparent 2" tube containing carboxymethylcellulose solution.

4.2.4 Recovery of TTI particles from the processes, tanks or bags

Recovery of TTI particles from the fruit mixtures created one of the most difficult challenges. This required the TTI particles to be recovered either from 250 to 1,000 kg batches of fruit products, or directly from a continuous processing system. Capturing all of the TTIs was further complicated by the need to ensure that a TTI particle travelling through the processing system either at the start or end of the batch was also found and did not end up in the factory drains. Therefore, both fruit product diluted with residual water in the clean pipework and the flushing starch and/or water used at the end of the batches had to be collected.

Collecting all of the fruit and TTI particles was relatively simple with some of the processes, for example with fruit products which were filled into 8.5 kg Pergal bags. Figure 4.4 shows the Pergal filling system in which there was manual control of the start and end of the filling procedure. Pergal bags were hot filled to avoid particle breakdown that can occur during tubular cooling. Bags were then cooled to a temperature at which the fruit could be handled

and then cut open with a knife. The contents of the bags were spread onto sorting trays and the TTI particles identified by visual differences. The small weight of fruit enabled each Pergal bag to be sorted with ease.

However, dark fruit products, such as blackcurrants, caused difficulties because of the intensity of the sauce colour. Poor TTI particle recovery was often a problem with these products. Despite issues with dark coloured fruits, transparent Sylgard 184 TTI particles showed up easily in most fruit products of a lighter colour. For ease of TTI recovery, the approach adopted after one particularly difficult blackcurrant trial was to conduct TTI trials, where possible, using lighter coloured fruit.



Figure 4.4: Pergal bag filling system showing one filled 8.5 kg bag per tray.

A greater challenge, because of the increased scale, was to find TTI particles from the bulk end product tanks (see Figure 4.5). These tanks are filled aseptically and are transferred by lorries to companies manufacturing yoghurt and dessert products. The fruit preparations are intermediate products that are mixed into yoghurts or kept separate as fruit corners.



**Figure 4.5: Bulk tanks used to store pasteurised fruit preparations.
Each of these tanks holds 800 kg of fruit.**

These end product tanks typically contained either 400 or 800 kg of product, which required considerable time to sort through and find the TTI particles. During the first TTI trials, it was common to spend 3-4 hours sorting through the batches. However, with practice, and with help from the factory fruit sorting team, this could be done in around 1 hour. Figure 4.6 shows an example for an apricot product where the fruit was spread into a mono-layer onto the sorting tray.

Various more elaborate methods were proposed, and some tried, in attempts to use technology to identify TTI particles within the large volume of fruit. None of these were 100% successful. These methods included ultra-violet, metal detection, magnets, X-rays and luminescence. Metal detection was one method where significant efforts were made to apply this on-line. The primary application for metal detection was to recover TTI particles directly from a continuous system where the heating process had to be measured but not that in cooling. Cooling would otherwise interfere with the analysis process because of its

contribution to pasteurisation. One example of a process in which control of cooling time was important was in the mixing vessels in which the pasteurisation was delivered within these vessels. Pasteurised product could not be released to filling until the thermal processing target was achieved. If a TTI particle travelled through the entire system, it would measure the total process, which would include the cooling contribution. A system was required that allowed the TTI particles to be located or ejected at the end of heating. One such system was metal detection linked with automatic rejection of food containing metal.

Metal detection technology was tried for ejecting TTI particles containing pieces of metal using on-line metal detectors. This still remains one of the greatest challenges for TTI work although the challenge is more with the detection and rejection mechanisms rather than construction of a TTI particle containing metal. Figure 4.3 shows several examples of TTI particles that were constructed with metal inserts such as 3-4 mm ferrous bearings or small ferrous nuts. The size of metal was sufficient to trigger the metal detector but not too large that the TTI particle density could not be brought back to the target by using low density foams in the particle construction. The TTI particles were tested on fruit products at the Okehampton factory but also at different food manufacturing sites with flowing meat products such as pie fillings.

Several technical issues were identified with using a metal detection system for locating and ejecting TTI particles:

- The first was in using sufficient metal to activate the detection sensors without adversely affecting the TTI particle density. The food product reduces the sensitivity of in-line metal detectors if the metal is situated in the centre of a pipe and surrounded (insulated) by the food. The solutions are either to increase the size of the metal component or to increase the detection sensitivity. However, there are some products that cannot operate at high levels of sensitivity, for example tomatoes, because of the natural presence of iron compounds that activate the sensors too frequently.
- The second was in the setting of the valves so they reject product containing the metal. Once a metal detector is activated by the presence of metal in the food, a valve opens after a pre-determined time that depends both on (a) the distance between sensor and valve and (b) the flowrate. This valve should remain open to allow a quantity of rejected product to

go to a collection bin, and the duration should be sufficient that the metal is within this product. Both timings must be set correctly. Experiences in factories were that valve systems were rarely found to be operating with the correct valve timings for the production flowrate. These must be changed each time the plant operates at a different flowrate otherwise metal-free product is ejected.

When a metal detection system was set up correctly, it was possible to recover the TTI particles by rejection into a collection bin. This provided a much reduced quantity of product to sort through, typically 3-5 kg for each rejection. Experience at different factories and with different metal detection systems showed that this method could be made to work but took time to set up and wasted a volume of product while testing the conditions. Neither time or product to test the system were usually available in a factory production situation and so in most TTI trials the recovery was done by sorting through products by hand. With practice and help from the factory staff, it was possible to sort through a 800 kg batch of fruit product in around two hours, with full recovery of TTI particles. Despite the advances in technology, hand sorting proved the most reliable method. Recovery of TTI particles by hand improved with experience, to the extent that it was rare for a TTI particle to get lost in a trial.



Figure 4.6: Sorting trays used for spreading fruit products into a mono-layer to aid in finding TTI particles. Product shown is an apricot preparation

4.3 Application of TTIs to fruit products processed in stirred vessels

4.3.1 Case Study 1: 400 kg batch of diced strawberries processed in a 1,000 kg stirred vessel

One of the first commercial tests for the amylase TTI particles was to measure the thermal process for a 10-12 mm nominal strawberry fruit preparation containing 40% frozen fruit by weight. The target thermal process for high acid fruit products was to achieve at least a 6-log reduction in heat resistant mould ascospores and acid-tolerant bacteria. This equated to the equivalent process of 5 minutes at 85°C. Chapter 1 contains more details of target pasteurisation processes.

The objective of the strawberry trial was to test the integrity of the silicone particles through a high shear industrial process and, if successful, to gain a measure of the level of pasteurisation achieved. Table 4.2 contains information on the batch sizes and numbers of TTI particles used in this and subsequent fruit trials.

Figure 4.7 shows a schematic layout of the fruit processing line at Kerry Aptunion (Okehampton). Figures 4.1 and 4.2 are pictures of similar vessels in this factory. Vessel capacity was 1,000 kg with a batch size of 400 kg. A small batch was chosen for the TTI trials for two reasons; it would heat faster therefore represent ‘worst case’, and there was less product to sort through when recovering the TTI particles.

The batch was heated from an initial temperature of 15°C to the end temperature of 90°C. The steam jacketed vessel (T. Giusti Ltd, Wellingborough) used horizontal scraped surface agitation at 15 rpm to minimise fouling. Steam temperature in the jacket was pressure-regulated at 105°C. Batch heating time was approximately 80 minutes. Once at the 90°C end temperature, the batch was held for 5 minutes in the vessel before cooling to 35-45°C in a 5-pass, 48 mm diameter Tetra Spiraflo (Tetra Pak Processing Components AB, Lund, Sweden). Cooling media or the tubular coolers was mains water at 8-12°C. Product flowrate during cooling was 1,200 L.h⁻¹, resulting in a mean residence time in the cooling tubes of 160 seconds. Control of fruit product flowrate during cooling was achieved by manual adjustment of the speed on a Waukesha circumferential piston pump. This was a positive displacement pump with two concave rotors.

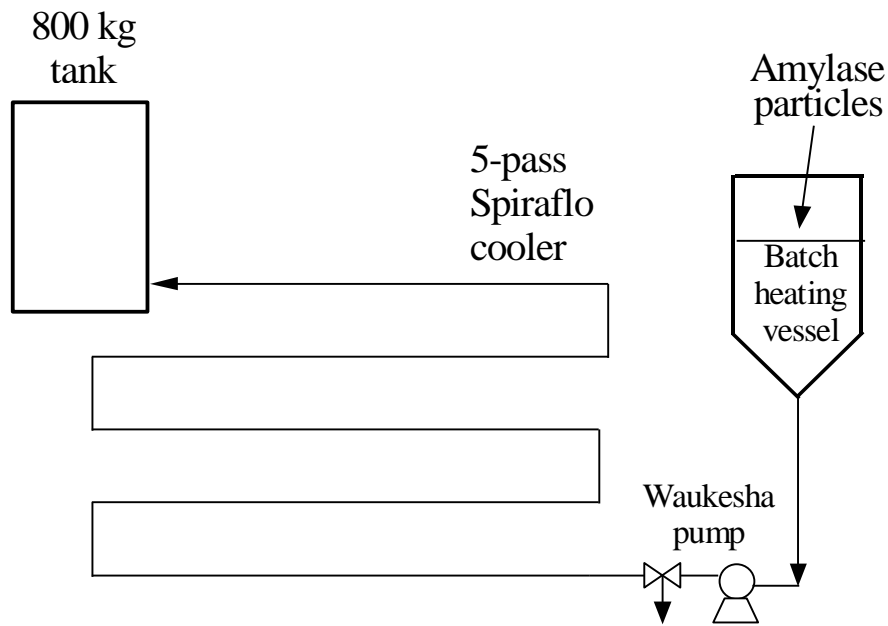
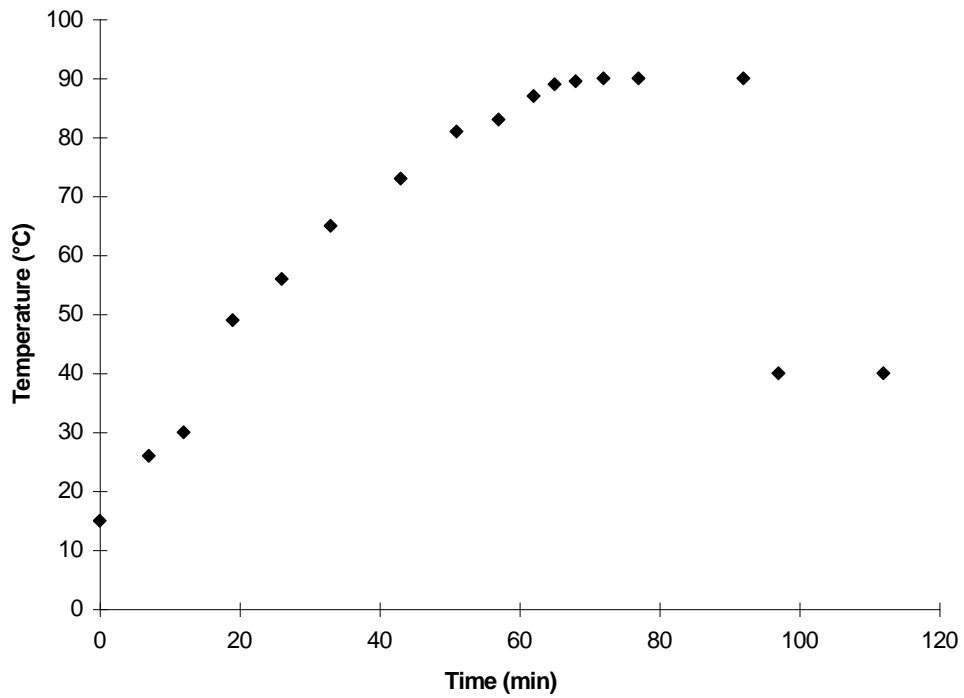

Figure 4.7: Schematic layout of the fruit processing line used for production of two batches of a strawberry fruit product

Figure 4.8 (a) shows the heating and holding profile of the carrier liquid, taken by manual temperature sampling at the slowest heating positions. These positions were around the central shaft where agitation was at a minimum and the distance from the heated surfaces was at a maximum. Locating the slowest heating positions was a ‘hit and miss’ procedure that took several seconds before the appropriate temperature was taken. These temperature measurements were done so that the rate of liquid heating could be evaluated and converted to a P-value for comparison with P-values measured from TTIs. When fruit batches are processed in production conditions, the temperatures are taken less frequently in order to minimise heat losses. This enables the vessel lid to be closed for longer times.

(a)



(b)

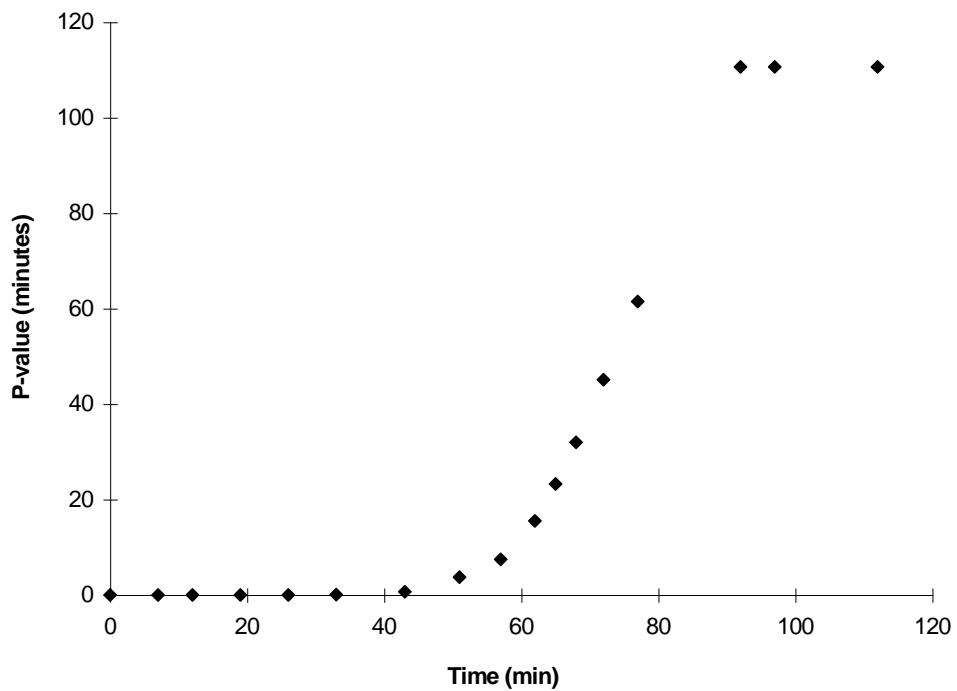

Figure 4.8: Heating profile of the strawberry carrier liquid, taken by manual temperature sampling of the vessel cold spots. (a) time-temperature profile, (b) time-P-value profile calculated with T_{ref} 85°C and z 9.7°C. Cooling points assumed fruit product exited the vessel immediately.

The 10 mm amylase particles were retrieved from the 400 kg tank at the end of the process using a coarse sieve that allowed the liquid to drain through. 10 of the 12 amylase particles were recovered intact at the end of the process, with evidence of particle breakdown found for the other two. Amylase solution was extracted from the centre of each of these particles and assayed for remaining activity. Results from the assays were converted to P-values using D-values for reference temperatures of both 80.7 and 85.0°C (see Table 4.2). Two temperatures were used because the calibration bath was set at 80.0°C (actually measured at 80.7°C) and the reference temperature for destruction of microorganisms for this high acid fruit was 85.0°C.

Table 4.2: P-value results from the amylase trials (in a stirred vessel with tubular heat exchanger cooling), for a diced strawberry product. Note that the liquid P-value was 111 minutes from Figure 4.8(b).

TTI particle number	Amylase activity (min⁻¹)	P-value for D_{80.7} (minutes)	P-value for D_{85.0} (minutes)
1	0.003	45.9	17.1
2	0.011	35.3	13.2
3	0.011	35.3	13.2
4	0.007	39.0	14.5
5	0.005	22.3	8.3
6	0.054	22.4	8.4
7	0.003	45.9	17.1
8	0.003	45.9	17.1
9	0.002	49.1	18.3
10	0.003	45.9	17.1

Measured particle P-values ranged from 8.3 to 18.3 minutes. A liquid P-value of 111 minutes was calculated from the time-temperature information taken at the vessel cold spot and is shown in Figure 4.8 (b). Fruit product remaining near the heated walls throughout the process

was likely to have received a process considerably greater than at the cold spot. TTI particles were free to move within the batch and so will have experienced hot and cold regions during the process. Heat transfer efficiency from the vessel wall to the starch-based carrying liquid and subsequently to the strawberries cannot be controlled uniformly throughout such batches. The end result was a distribution of P-values from 8.3 to 18.3 minutes. This was substantially lower than the liquid; this suggests that the particle centres were not at 90°C when steam was turned off to the jacket.

The P-value distribution from the TTI particles included a contribution from the continuous flow cooling. At the end of the 5 minute hold at 90°C in the vessel, hot product remained in the vessel for between 0 and 40 minutes while being pumped through the Tetra Spiraflo cooling tubes. Although the product temperature was not maintained at 90°C in the vessel during cooling, some product experienced up to 40 minutes extra heating. Batch temperatures after the steam was turned off started at 90°C but fell to 70°C in the 40 minutes before the last fruit particles entered the cooling tubes.

Two of the silicone particles broke at the join between the two moulded halves and several had their corners removed. Improvements to the methods of moulding the particles were made following the strawberry trial, to strengthen the silicone particles, and thus recover a greater percentage of them intact. This involved a reduction in time between setting of the first part silicone in the base of the mould and in pouring the top part. Excess time caused the silicone to set too much so the join between parts was a weakness. By allowing the silicone enough time for its viscosity to increase sufficiently, but not fully cure, the TTI tube remained in position while the top part was poured. This required around 6-8 hours at room temperature or 2-3 hours at 40°C.

An improved method of encapsulating the amylase solution was developed for all TTI work following the strawberry vessel trial. This involved silicone tubes of 2.0 or 2.5 mm diameter in which the amylase solution was encapsulated between two elastomer end plugs. This formed a high strength TTI tube that could be used as the tube itself or moulded into silicone shapes that represented the thermal pathway for a target food particle. Details of this method are given in Chapter 2, section 2.3.

4.3.2 Case study 2: 500 and 430 kg batches of pineapple & passion fruit processed in a 1,000 kg stirred vessel

The fruit product for the second TTI trials was a pineapple and passion fruit mixture with 10-12 mm pineapple cubes. This product was chosen so that the same 10 mm particle moulds used a case study 1 could be used but with a greater number of replicate particles. Product composition was 26.6 wt% of 10-12 mm pineapple cubes, with various thickeners (0.36 wt% pectin, 0.23 wt% LBG, 2.75 wt% starch) and sugar, water, flavourings and colourings. The processing method was similar to that for the strawberry fruit preparation. Temperature sampling of these batches was not done until they were close to 90°C to avoid losing heat that would otherwise increase the batch times.

The objective of the pineapple and passion fruit trials was to use the amylase particle method to validate the efficacy of the delivered thermal process. This included contributions in the processing vessel during both heating and holding, as well as during cooling in the tubular heat exchanger. Batch sizes were chosen to be the lowest that would be run in normal production and as such would heat up more rapidly than the typical batches of up to 800 kg. Large numbers of amylase particles were chosen so that the distribution of P-values could be assessed (see Table 4.1 for number of TTI particles used in the various fruit trials).

To ensure that the TTI P-values represented the worst case values, as required when validating the safety of a thermal process (IFTPS, 1995), the cubes were sized to heat more slowly than the fruit pieces. This was achieved by calculating the TTI particle dimensions using the f_h Equations 2.10 and 2.11 and rounding up the fraction to the nearest integer in millimetres. For example, a cube calculated at 9.7 mm was rounded up to 10.0 mm.

In the first pineapple and passion fruit batch, 71 out of 75 TTI particles were recovered intact and in the second batch all 45 were recovered. In the first trial, however, the method used for sealing the hypodermic entry hole was poor and it was possible to extract 20 µL of amylase solution from only 21 of the 71 particles. The sealing method was further improved for the second batch and all 45 particles retained their amylase solution. Figures 4.9 and 4.10 present the distributions of P-values calculated from the reductions in amylase activity with a D_{85} of 6.95 minutes. The minimum P-values were 10.1 minutes for the 500 kg batch and 6.0 minutes for the 430 kg batch. These compared favourably with the target of 5 minutes at 85°C.

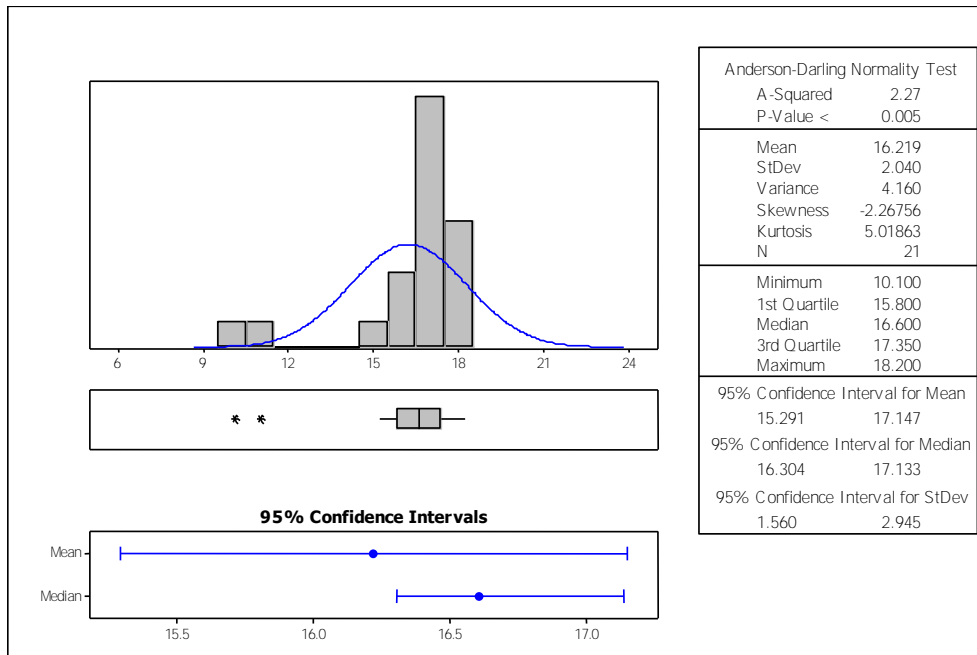

Figure 4.9: Distribution of pasteurisation values for the 500 kg batch of 10 mm pineapple and passion fruit product, calculated with $D_{85} = 6.95$ minutes. Sample size 21. Explanation of the graphs is given in Chapter 2 section 2.8.

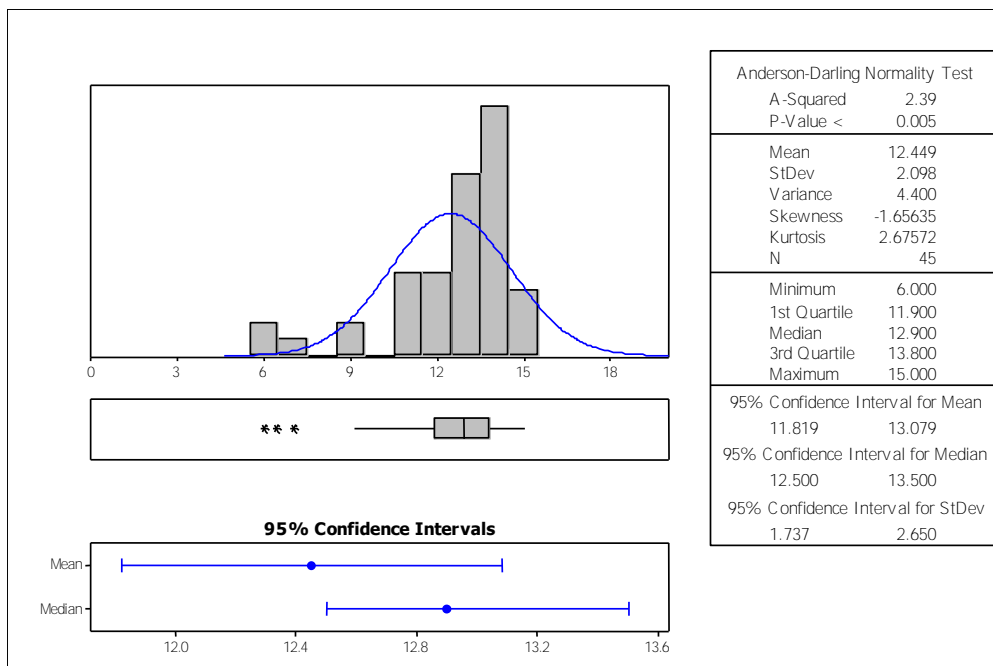

Figure 4.10: Distribution of pasteurisation values for the 430 kg batch of 10 mm pineapple and passion fruit product, calculated with $D_{85} = 6.95$ minutes. Sample size 45. Explanation of the graphs is given in Chapter 2 section 2.8.

Both P-value distributions showed that the majority of particles were processed to levels of P-values considerable higher than the target of P 5. Only a small proportion of TTIs resulted in P-values towards the lower end of the measured range. When analysed with the Minitab statistical package, the two lowest P-values in Figure 4.9 and three lowest in Figure 4.10 were identified as outliers from a normally distributed population. However, they are believed to be valid measurements of P-values, which may have been caused by the difficulties in mixing high viscosity products. It is known that horizontal agitation gives rise to slowest heating regions around the central shaft (Mehauden, 2007) and so the three TTIs with low P-values may have spent most of their time in these regions. It is likely that just a few TTI particles would spend time around one region and so only a few TTI P-values would be expected to be low.

Buoyancy was thought to be another of the reasons behind the non-normal distribution and particularly responsible for the high P-values. These fruit preparations contained high quantities of sugar, which resulted in carrier liquid densities in the range 1,200-1,300 kg.m⁻³ at 20°C. Mean TTI particle density was close to 1,050 kg.m⁻³ at 20°C and was unlikely to decrease markedly with temperature as with the carrier liquid (because of the reduced thermal expansion of the solid silicone materials compared with that of the carrier liquids). Hence, the TTI particle buoyancy changed during the process. This change in TTI particle density (and buoyancy) was also expected to occur with the fruit pieces, albeit to a lesser extent. Particle sedimentation or flotation effects were reduced at low liquid temperatures by the high liquid viscosity that restricted particle movement. However, it was likely that many of the TTI particles rose towards the surface of the pineapple and passion fruit mixture during the latter heating stages in the vessel. If this occurred, these TTI particles would remain in the hot fruit for up to 40 minutes while the vessel was emptied, resulting in high P-values for the majority of the TTI particles. Evidence that this did occur was obtained when recovering the TTIs from the 800 kg end product tanks. Many of the TTIs were found in the last 50-100 kg of fruit, which was filled towards the end of the batch.

4.3.3 Case Study 3: 325 kg batch of apricot processed in a 1,000 kg stirred vessel

Having improved on the method for manufacturing 10 mm amylase particles, a trial was conducted to validate the pasteurisation achieved at the centre of a larger fruit piece. The

product chosen was an apricot that contained roughly chopped apricot given by the fruit suppliers as a nominal 20 mm. Equation 2.10 was used to calculate an equivalent thermal pathway, and so 14 mm TTI particles were constructed from the moulds so they heated at a similar rate to the 20 mm apricot pieces. 45 TTI particles were added to the batch with five retained for unheated controls.

A small batch of 325 kg was used so the rate of heating represented the fastest that was likely to occur in normal production; this resulted in the minimum levels of pasteurisation for the same end batch temperature of 90°C. Product composition was 44 wt% of 20 mm apricot, 8.9 wt% of Clearam CH20 starch thickener added as 1:2 slurry:water, sugar, water, flavourings and colourings. Temperature sampling of the processing vessel was done at infrequent intervals until the temperature was close to 90°C, to avoid unnecessary heat loss. When processed, the product was hot filled into 5 kg Pergal bags directly from the vessel and the bags cooled rapidly in a forced convection chiller. TTI particles were recovered from the Pergal bags once the fruit product had cooled to a temperature that it could be handled.

Recovery percentage for the TTI particles was good, with 44 of 45 amylase particles recovered intact, and one other particle found in two halves. Each intact particle had retained its amylase solution, which allowed 44 assays to be completed. This was a satisfactory outcome from a process that contained much potential for shear damage to the 14 mm amylase particles during the heating, pumping and filling stages. One assay test was compromised while extracting the amylase from the TTI particle. Figure 4.11 presents the distribution of P-values as measured from a reduction in amylase activity and with a measured D_{85} of 6.95 minutes. The minimum P-value was 9.7 minutes, and with the target being to exceed 5 minutes, these results confirmed that the target for this product was achieved.

The shape of the P-value distribution for the apricot product was, once again, not normally distributed. There were two reasons proposed for this. Firstly, it was likely that the TTI particles were more uniformly distributed throughout the product in the vessel than with the previous trials. This was because of the closeness in density of the carrier liquid and silicone TTI particles. Both densities were measured at $1,100 \pm 50 \text{ kg.m}^{-3}$. Artificial sweetener was used in the low-sugar apricot product and therefore the carrier liquid density was lower than the other high-sugar recipes. Secondly, cooling was performed within Pergal bags rather than

in a tubular heat exchanger. This may have resulted in more uniform batch cooling since the bags were placed in the chiller once all had been filled.

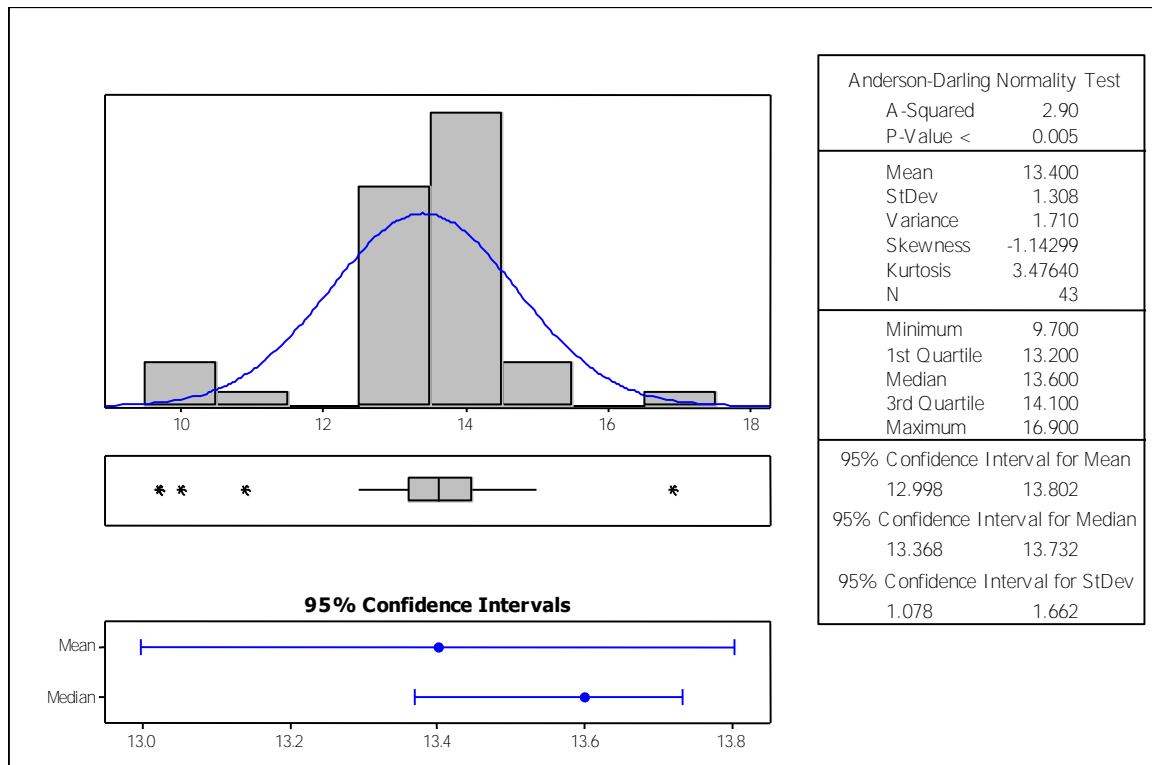

Figure 4.11: Distribution of pasteurisation values for the 325 kg batch of 20 mm apricot, calculated with $D_{85} = 6.95$ minutes. Sample size 43. Explanation of the graphs is given in Chapter 2 section 2.8.

4.4 Application of TTIs to fruit products processed through a tubular heat exchanger

Previous TTI trials described above had shown that the TTI method provided P-value data that represented measurements from the centre of moving fruit pieces. The next challenge for developing the TTI method was to determine the pasteurisation levels achieved in the core of 12 mm pear pieces heated and cooled in a Tetra Spiraflo tubular heat exchanger. This type of measurement had not been attempted with this specific equipment and so the range of P-values expected was unknown. For this reason, both BAA85 and BLA90 TTIs were used, which extended the measurement range from a few minutes at 85°C with BAA85 to almost

one hundred minutes with BLA90 (see Chapter 1 for details on D and z information). Target P-value for this product was 5 minutes at 85°C, the same as for the previous fruit products, and measured at the centre of the fruit pieces. Set-point temperature for controlling the process was measured in the liquid phase, and so did not represent a temperature at the centre of the pear pieces, which was the critical position for food safety. Therefore, the purpose of using the TTIs was to prove that the minimum target process was achieved despite the exchanger controls being based on liquid temperatures.

4.4.1 Case Study 4: 1,000 kg batch of pear & toffee processed in a 22 mm diameter tubular heat exchanger

A high number of TTI tubes were prepared for this trial so that a distribution of P-values was obtained. Hence, 80 silicone tubes of length 8 mm and inside diameter 2.5 mm were prepared: 40 tubes contained BAA85 and 40 contained BLA90. In order to produce TTI particles that were of similar heat transfer behaviour to 12 mm pear cubes, 10 mm cubic moulds were used. Chapter 2 describes the physics of estimating the TTI particle sizes.

From each set of TTI particles, 5 were put aside and kept as controls from which the initial amylase activity was measured. These controls were taken into the factory so that they experienced the same environmental conditions as the TTI particles used to measure process values. The remaining 70 TTI particles were incorporated randomly into the feed tank.

A 1,000 kg batch of pear and toffee product was prepared in a 1,000 kg mixing vessel and pumped to the 2" tubular heat exchanger at 70°C. Flowrate was 850 kg.h⁻¹. The system included multiple tubes in series; seven steam-heated tubes, seven insulated holding tubes and eleven water-cooled tubes, each of which were 6 m in length (see Figure 4.12). Actual hold tube length, inclusive of bends, was 47.0 m, which gave a minimum residence time of 180 seconds assuming laminar flow and a centreline velocity of twice the mean velocity. Note that Reynolds numbers in the hold tube were very low because of the high viscosity and therefore the flow was laminar. A set-point of 92°C at the exit from the heaters was used to ensure the minimum P-value of 5 minutes at 85°C was achieved at the core of the pear pieces. Hold tube exit temperature for the divert valve was set at 88°C in order that the hold tube process was greater than 88°C for 3 minutes; this actually achieved a P₈₅-value of 6 minutes (T_{ref} 85°C, z

10C°). Controlling the product temperature at the hold tube exit was not possible because of the thermal lag created by the volume of product in the holding tubes.

When the mixing vessel was emptied of product, a pigging system was used to recover the valuable fruit product through 150 metres of exchanger pipework. The pig was a tightly-fitting, plastic-coated iron sphere that operated at a constant 6 bar air pressure. This pushed the product out of the pipework and minimised wastage.

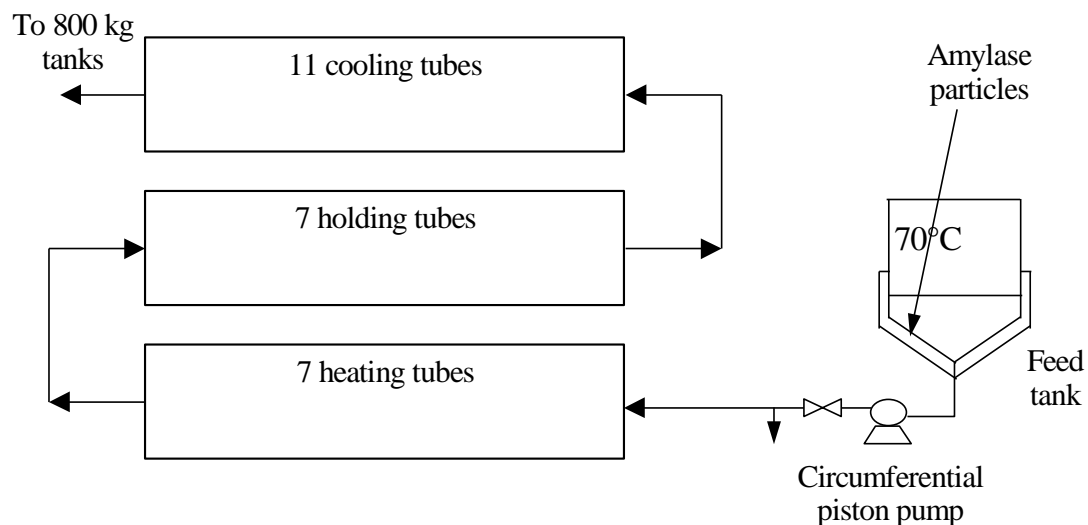

Figure 4.12: Schematic diagram of the tubular heat exchanger used to process the 12 mm pear and toffee product.

On completion of the processing, all 70 TTI particles were recovered from the two tanks of processed pear & toffee product. This was done by spreading the pear and toffee mixture over stainless steel sorting trays. One TTI particle was found cut into two pieces, presumably by one of the solenoid on/off valves, so amylase from this TTI was compromised.

Both BAA85 and BLA90 TTIs were assayed for residual activity. BAA85 TTIs had little residual amylase activity; the thermal process must have been greater than the upper measurement limit for this TTI. No further analysis was done with the BAA85 TTIs.

However, BLA90 TTIs provided P-values that were within the measurement range. These are

displayed in Figure 4.13. P-value calculations used a D-value of 66.6 minutes at the reference temperature of 85°C. Highest P-value was 109 minutes and the minimum P-value was 33 minutes.

The target to achieve commercial sterility for this product was 5 minutes at 85°C, therefore a substantial safety margin existed. This degree of safety margin is typical of industrial continuous flow processes for products with particles. This is because process control actions must act on sensor information from the carrier liquid, however, the critical position for the process is at the centre of the moving particles. In order to allow for the lag in heat conducting from the hot liquid to the colder particle centre, generous operating margins are allowed. These margins also allow for the distribution of residence times experienced by the particles as they flow through 150 metres of 2” pipework.

The frequency distribution for TTI-measured P-values in Figure 4.13 showed that most particles received thermal processes within the 50 to 65 minutes range (equivalent to 85°C). Mean P-value was 59.6 minutes. P-value distribution was not normally distributed.

The high P-value of 109.7 minutes in Figure 4.13 was likely to have been caused by the influence of the pigging operation on cooling behaviour. The plastic pig was propelled through the tubes by a constant 6 bar air pressure. Towards the end of the pigging operation the back pressure caused by frictional resistance of the product in the tubes decreased. This in turn caused the flowrate to increase and the cooling to be less effective. Thus, the product in the last few tubes received a reduced amount of cooling and entered the finished product tanks at an elevated temperature. Any TTI particles found in this hotter product were likely to have received higher levels of pasteurisation than those cooled at the normal flowrates. There was one TTI particle with a P-value some 20 minutes greater than the next highest (this was the high P-value outlier in Figure 4.13), so it would be reasonable to assume this TTI particle was in the last product from the vessel.

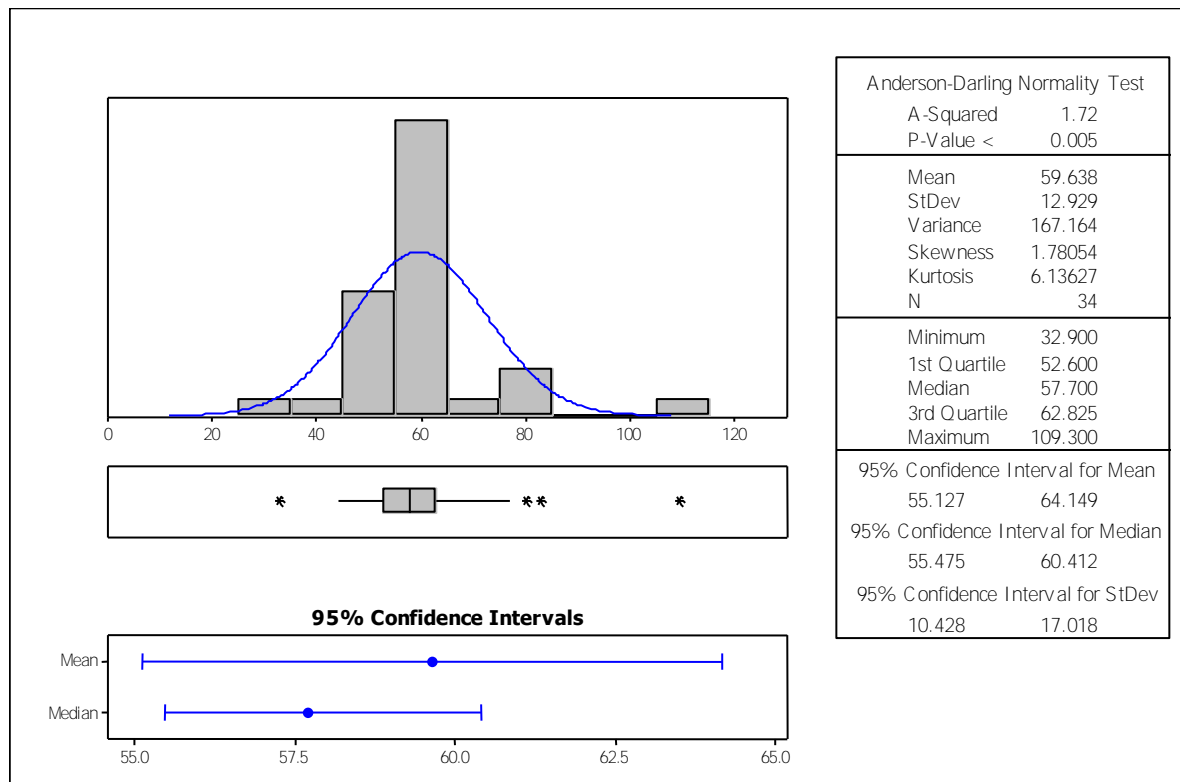

Figure 4.13: Frequency distribution for 10 mm silicone TTI cubes representing 12 mm pear pieces in a pear & toffee fruit preparation, processed in a tubular heat exchanger. Sample size 34. Explanation of the graphs is given in Chapter 2 section 2.8.

4.5 Application of TTIs to fruit products processed through an ohmic heater

Ohmic heating is a relatively new technology that has struggled to find a market in the food industry (CCFRA New Technologies bulletin No. 32, 2006). The only current production system in use in the UK is now owned by Kerry Aptunion and used for pasteurising fruit products. This application is ideal for ohmic heating because there is a high proportion of delicate particle matter in the product and it is suspended in a high viscosity carrier liquid. As with other continuous heating and cooling systems, it is difficult to validate the levels of pasteurisation achieved at the centre of the moving food pieces. This was a new challenge for TTIs.

Ohmic heating is the generation of heat by the passage of alternating electrical current (AC) through a body such as food, and has been in use since the nineteenth century. Other names

for this technology include resistance heating, direct resistance heating, Joule heating and ElectroheatingTM. Ohmic technology relies on the electrical resistance of the food to generate heat (De Alwis and Fryer, 1990a), therefore if the electrical resistances of all components of the product are constant then the product heats uniformly. The technology is limited by the fact that heating is dependant on the electrical conductivity of the food. As a consequence, materials such as fats, oils and distilled water that are not ionically loaded are not suitable.

Claimed advantages of ohmic heating over conventional heat exchangers can be summarised as follows:

- Rapid and uniform heating,
- Particles can reach higher temperatures than the surrounding liquid,
- High quality products,
- Reduced fouling on certain products,
- Greater energy efficiency than with conventional heat exchangers,
- Instant switch on and off,
- Reduced maintenance,
- Quiet (dependent on type of pumps, etc),
- Environmentally friendly.

Ohmic heating is not a new principle, in fact, several processes were patented for the use of electrical currents to heat pumpable liquids in the 19th Century (de Alwis and Fryer, 1990b; Ruan et al, 2004) and it was used for milk pasteurisation in the early 20th Century. APV Baker licensed a continuous ohmic heated developed by the Electricity Council of Great Britain with improved electrode material in 1988 (Skudder, 1988).

The principle of ohmic heating is based on passing an alternating electrical current (AC) through a system, such as a liquid-particle food product, in which the food presents an electrical resistance to the current (De Alwis and Fryer, 1990b). The rate of heating is directly proportional to the square of the electric field strength and the electrical conductivity. The electrolyte (e.g. salt) content can be altered to improve the effectiveness of heating because conductivity is influenced by the ionic strength. As the temperature increases, so usually does the electrical conductivity, meaning that efficiency of ohmic heating increases at

higher temperatures. This can cause potential problems of over heating, therefore sophisticated controls are required on the applied voltage to ensure the temperature of the product at the column outlet is controlled.

It is estimated that there are at least 18 commercial plants in operation across Europe, US and Japan (Ruan et al, 2004). The real success of this technology has been in the area of fruit and vegetable processing, and multiphase products. This is because the rate of heating for particles and liquid can be controlled so they heat at the same rate.

One of the main concerns with ohmic heating is how to ensure that the desired scheduled process has been delivered. As with other thermal processes, the scheduled process needs to be validated. Since ohmic heating is a thermal process, temperature and time are the principal critical process factors. With a continuous flow ohmic heater there are several other factors that influence the temperature. These include the electrical conductivity of the different phases, the temperature dependence of the electrical conductivity, the heating device design, the fluid motion, residence time distribution (RTD, sometimes referred to as passage time distribution, PTD), the thermophysical properties of the food, and electric field strength (Kim et al., 1996b; US FDA, 2000).

There are two factors that simplify the procedure of validation; these are (1) the possibility of faster heating of the particles having lower electrical conductivity than the fluid and (2) a near plug flow behaviour of products with high solid content (Kim et al, 1999). Significant research has gone into determining the worst-case scenario (Zhang and Fryer 1993; Sastry and Salengke 1998), as unlike conventional heating, the worst case may not be associated with a static situation or may be in the liquid rather than the particles.

4.5.1 Case Study 5: 250 kg batch of whole strawberries processed in a 75 kW ohmic column

Prior to this TTI work, validation of the thermal process achieved in an ohmic heating system used microbiological spore methods (Brown et al., 1984). A feasibility trial was set up to determine whether the TTI method could be used to measure P-values for fruit products. Case study 5 describes this trial, which was of key importance in making improvements to the TTI methods for application to ohmic heating.

The 75 kW commercial ohmic heater (APV Ltd, Crawley) used four PTFE lined electrodes that gave a capacity of 750 kg.h^{-1} (see Figure 4.14). The product was a 250 kg batch of strawberry fruit preparation containing whole strawberries in a high viscosity carrier liquid. The holding tube was 3" diameter and 16.4 m in length, with a small vertical rise from inlet to outlet to prevent trapped gases from collecting at the low point. At 750 kg.h^{-1} the minimum holding tube residence time was calculated at 180 seconds. This assumed the centre tube velocity was twice that of the mean velocity; this is the worst case situation for laminar flow of a Newtonian liquid. Actual measured particle residence times for holding tube flow with fruit products have shown that this is not the case (Kim et al., 1996b; Tucker, 1999a). However, the commercial practice is to assume worst case.

Cooling was achieved using a series of 2" diameter water-cooled tubular heat exchangers. A gelatinised starch solution made up at the same conductivity as the strawberry fruit preparation was pumped through the ohmic column to recover as much of the strawberry product from the pipework before diverting to drain. Processed product was filled into a 400 kg finished product tank at temperatures between 25 and 50°C.

Heating of the strawberries took place via volumetric resistance heating and at a faster rate than the surrounding carrier liquid. Evidence for this was the increase in holding tube temperature of approximately 5-10°C from inlet to outlet as the particles transferred their heat to the surrounding liquid. Heating rate of the solid and liquid components was controlled using the electrical conductivity of the liquid, which was measured at around 0.24 S.m^{-1} at 20°C.

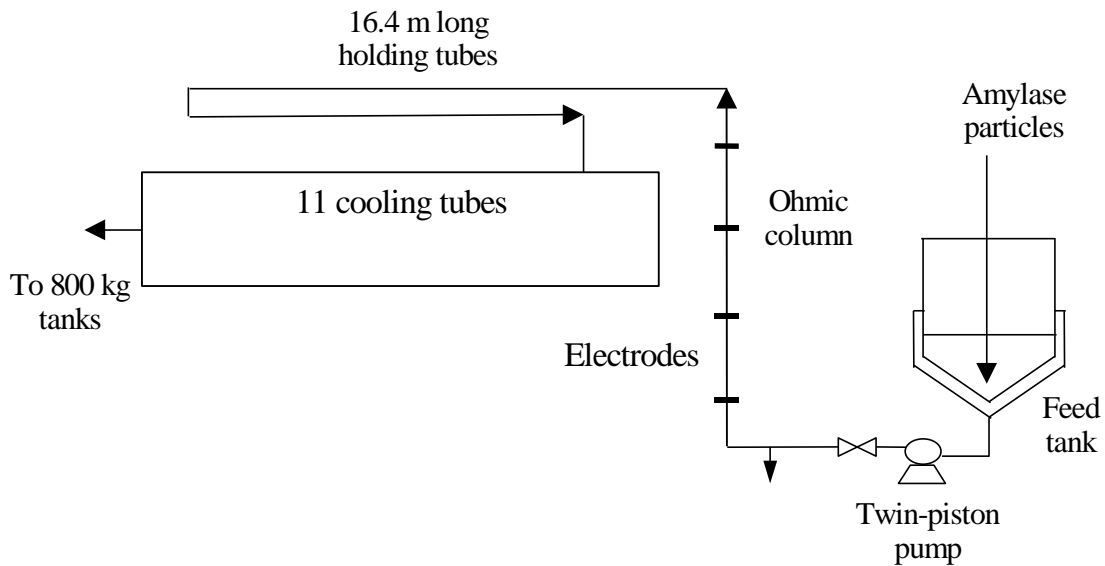

Figure 4.14: Schematic diagram of the 75 kW ohmic heater, a 16.4 m holding tube and 11 passes of 2” tubular heat exchanger.

The objective of the trial was to test the amylase TTIs as a validation method suitable for measuring process values with the ohmic process. At this stage in TTI method development, the BAA85 solution was encapsulated by injection into trapped air bubbles within Sylgard 184 compound. This method pre-dates that described in Chapter 2 and was found inferior to encapsulating amylase solution within sealed silicone tubes; TTI work subsequent to this strawberry trial used the TTI tube method rather than the TTI bubbles.

'Amylase strawberries' were constructed from whole frozen strawberries that had been allowed to thaw for one hour before insertion of the silicone-encapsulated amylase. Approximately 30-40 μL of BAA85 solution was injected into 3 mm diameter silicone bubbles held within 5 mm silicone cubes. The silicone cubes were inserted through a hole to the centre of the strawberries, and sealed with a calcium alginate gel. Water soluble blue dye was allowed to soak into the 'amylase strawberries' for one hour in order that they could be identified from whole strawberries in the 250 kg batch of fruit. A total of 15 whole 'amylase strawberries' were constructed and added to the 250 kg feed batch.

For the purpose of these trials, the target temperature at the holding tube inlet (ohmic column outlet) was manually controlled at 90°C by adjustment of the heat capacity value in the

control panel. Normal column operating temperature ranged between 92-95°C. This was thought to give rise to a level of over-process in the particles that was above the upper measurement range of the BAA85 TTI. Residual amylase activities would be low or zero, and so conclusions could not be drawn on process levels unless the column temperature was reduced.

Confirmation that the strawberries absorbed electrical energy at a faster rate than the carrier liquid was supported by the 10°C rise in holding tube temperature from 90°C at the inlet to 100°C at the outlet. This rise was caused by particles that heated preferentially to the liquid in the column and gave up their heat to the liquid as they flowed along the holding tube (Kim et al., 1996 a and b).

Calculation of P-value for the carrier liquid was done on-line within the plant software; using Equation 1.10 with the kinetic parameters of a reference temperature of 85°C and a z of 10°C. In Equation 1.10, the liquid temperature was taken from the sensor placed at the ohmic column outlet (hold tube inlet) and residence time was calculated from flowrate. P-values calculated from the software were applicable to the destruction of ascospores of yeasts and some medium heat resistant bacteria (CCFRA, 1992a). Target P-value was 5 minutes at 85°C, which for convenience was scaled up to an equivalent process at 90°C. For a minimum temperature of 90°C at the holding tube inlet, the requirement of an equivalent of 90 seconds at 90°C was easily achieved during operation. Most product received at least double the minimum P-value due to fluctuations in column temperature from 90 to 92°C.

Of the 15 processed 'amylase strawberries', 12 were recovered intact, with 1 found at the product/starch interface and 2 TTI bubbles had separated from their strawberries. Figure 4.15 presents the 12 individual P-values estimated from reduction in amylase activity and with a D_{90} of 123 seconds. The target equivalent process of 90 seconds at 90°C was exceeded by all amylase strawberries. Most TTI P-values were at least double the minimum P-value of 90 seconds at 90°C (equivalent to 5 minutes at 85°C). Error bars of $\pm 12.5\%$ were put on the individual TTI particle P-values as shown in Figure 4.15. Chapter 2 describes how these error estimates were made.

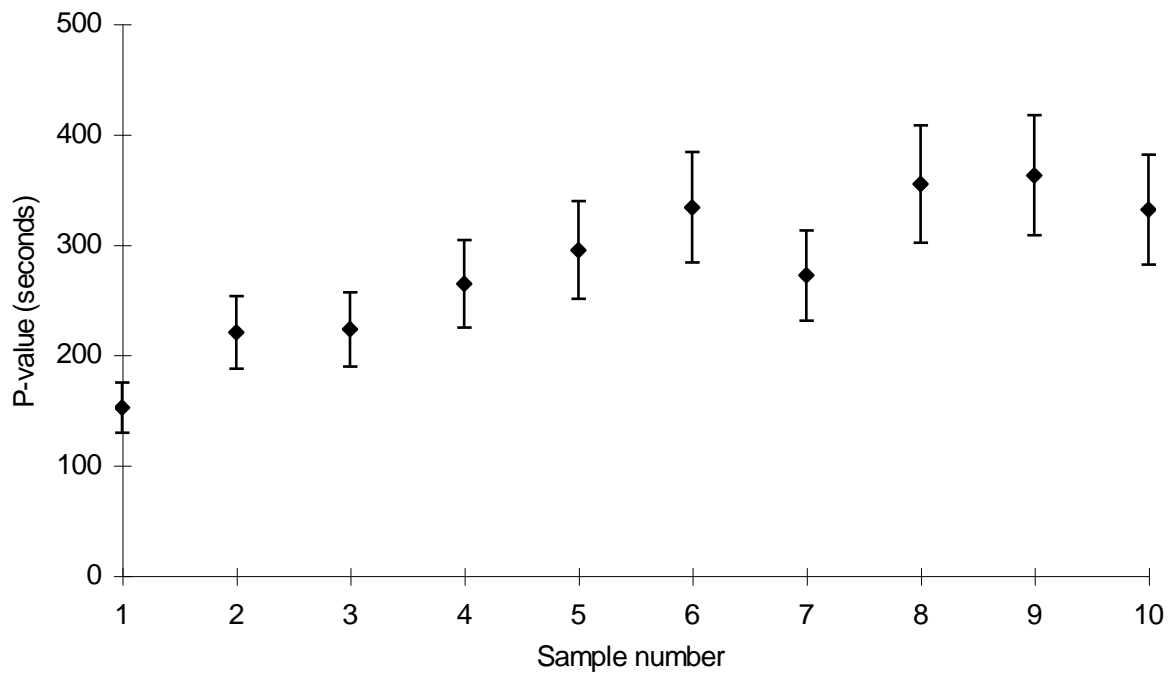

Figure 4.15: TTI P-values for a 250 kg batch of diced strawberry heated through a 75 kW ohmic column. P-values calculated using $D_{90} = 123$ seconds.

4.5.2 Case Study 6: 850 kg batch of blackcurrants and 790 kg of diced pineapple processed in a 75 kW ohmic column.

Encapsulation of the amylase solution within the silicone particles evolved to the improved TTI tube system following the above strawberry trial. Silicone tubes capped with Sylgard elastomer proved a more robust method than encapsulating amylase within silicone bubbles; the improved TTI tube method is described in Chapter 2. These tubes were the basis for the silicone particles that were then made up to represent the thermal and physical properties of the fruit pieces. Sylgard 184 elastomer was poured into plastic moulds to make the TTI particles. Chapter 2 describes how this was done.

Two trials with firstly a blackcurrant and secondly a pineapple fruit preparation were conducted in order to calculate the pasteurisation achieved at the core of the moving fruit pieces. Blackcurrants required an 8 mm spherical TTI particle and pineapple cubes required a 10 mm TTI particle; Table 4.3 shows the details of the two trials. The objective was to

measure the P-values achieved at production flowrates, using silicone TTI particles to represent the fruit. These TTI trials were carried out at the end of a production run to ensure that if any TTI particles were lost they would be removed with the water wash and cleaning programme.

The same 75 kW ohmic heater was used as with the strawberry; as shown in Figure 4.14. A 3” diameter holding tube of 16.4 metres in length connected the ohmic column to eleven 2” cooling tubes each 6 metres in length. The amylase used in the TTI particles was from BLA93 which had sufficient heat stability to measure P-values that were expected to be much higher than the process target of 5 minutes at 85°C. This was because the measurements on which the process was based were from temperature probes in the liquid; however, the ohmic system heated the fruit particles preferentially. P-values achieved in the fruit pieces were expected to be higher than those from the slower heating liquid.

The ohmic heater was operated at an average power of 60 kW giving a column outlet temperature of around 93°C and a holding tube exit temperature approximately 7°C higher. This rise in temperature along the holding tube confirmed that the fruit particles heated preferentially to the liquid. Flowrate for the blackcurrant was 850 kg.h⁻¹ and 790 kg.h⁻¹ for the pineapple.

Details of the experimental trials for case study 6 are given in Table 4.3. Silicone blackcurrants were made using an 8 mm spherical mould and those for pineapple used a 10 mm rectangular mould. TTI particles were introduced into the fruit mixtures by dosing into the tank outlet at intervals during tank emptying. This ensured a regular supply of TTIs to the fruit.

Table 4.3: Details of the numbers of TTI particles and conditions used for the ohmic heating trials with blackcurrant and pineapple pieces (* low particle recovery was caused by difficulties in identifying TTI spheres and in product loss down the drains)

	Blackcurrant	Pineapple
TTI particle dimensions	8 mm spheres	10 mm cubes
No. TTI particle for controls	4	4
No. TTI particles put in the feed tank	44	43
No. TTI particles recovered	29*	43
Feed batch size (kg)	700	650
Flowrate (kg.h ⁻¹)	850	790

Blackcurrant

TTI particles in the blackcurrant trial were recovered by rinsing the blackcurrant mix with water through a sieve that removed the liquid, making the silicone particles more visible. The TTI particles in the pineapple trial were marked, prior to processing, with a blue cross on opposite faces making them easily visible in the light yellow fruit mixture.

For the blackcurrant trial, only 29 of the TTI particles were recovered out of the 44 originally placed in the feed tank. Two reasons for the low recovery were proposed. Firstly, on the day of the trial, the ohmic operators did not realise they were supposed to collect all fruit material that might contain a blackcurrant or TTI particle. Instead, the trial took place as if it were a normal production run in which only good quality, saleable fruit was collected in the 800 kg finished product tanks. Hence, some blackcurrants prior to the start of filling and in the product/starch interface at the end of the batch were washed down the drain by mistake. Secondly, identification of the silicone TTI spheres amongst the dark blackcurrant mixture was difficult, and some may have been missed during sorting.

Calculation of P-values from the TTI particles required the BLA93 D-value to be converted for reference temperatures of 93 and 85°C; this used a z-value of 9.1°C. P-values were then

appropriate to an 85°C reference temperature. Equation 4.4 shows the equation used to convert the D-value from 93 to 85°C. D_{93} was measured using the same procedure as given in Chapter 2 and calculated as 8.8 minutes at 93°C. D_{85} was calculated from Equation 4.4 as 66.6 minutes at 85°C; this value was used in Equation 4.5 to calculate the P-values.

$$D_{85} = D_{93} \times 10^{\left(\frac{93-85}{9.1}\right)} \quad 4.4$$

$$P = D_{85} \cdot \log\left(\frac{A_{initial}}{A_{final}}\right) \quad 4.5$$

where, $A_{initial}$ is the initial amylase activity, minutes⁻¹

A_{final} is the final amylase activity after the ohmic process, minutes⁻¹

Amylase activities measured from the BLA93 spheres indicated a wide range of P-values, with the highest P-value of 159 minutes and the lowest value 52 minutes (see Figure 4.16).

The factory control panel during the process gave a Pu (pasteurisation unit) value of 93 ± 2 minutes. This value for the carrier liquid was calculated from temperature and time measurements:

- Temperature was measured from a sensor located at the ohmic column outlet; which measured the carrier liquid temperature, $T(t)$, and not the temperature from the fruit or TTI particles.
- Time (residence time in the hold tube) was calculated from a flowrate reading; which itself was calculated from the pump piston capacity and stroke speed.

Ohmic column outlet was at the same point as the holding tube inlet and represented the lowest carrier liquid temperature. Equation 4.6 was used in the ohmic software to perform the P-value calculations, which used a reference temperature of 85°C and a z-value of 10°C. These parameters were appropriate to a process for high acid fruits (CCFRA, 1992a).

$$P = \int_0^t 10^{\frac{T(t)-85}{10}} \cdot dt$$

4.6

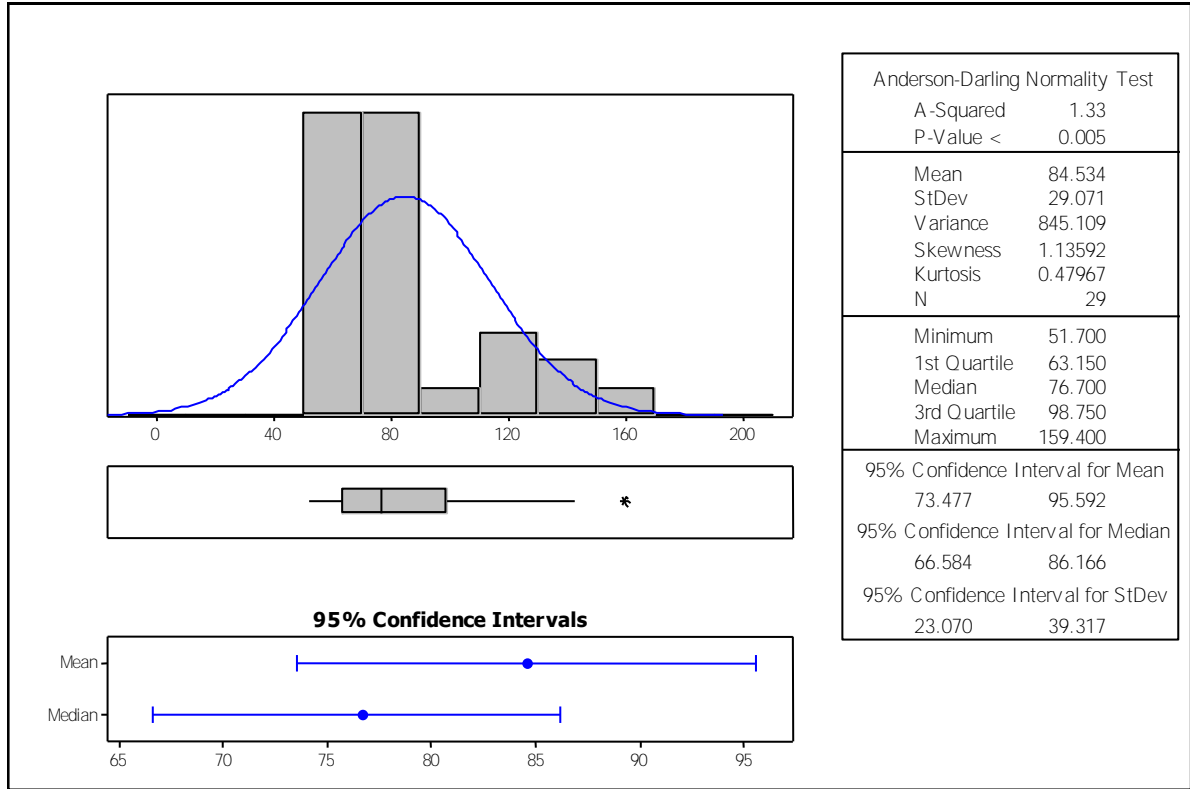

Figure 4.16: Frequency distribution for 8 mm silicone TTI spheres representing blackcurrants in a blackcurrant fruit preparation, processed in a 75 kW ohmic heater at 850 kg.h⁻¹. Sample size 29. Explanation of the graphs is given in Chapter 2 section 2.8.

Conventional heat exchangers, such as tubular heat exchangers, operate with the liquid pasteurisation levels considerably higher than with the particles because of the slowness of conduction into the particles. This is discussed in section 4.4.1 on the tubular heat exchanger trials with pear and toffee. As discussed in section 4.5.1, this situation is reversed in ohmic heating because of the different electrical heating rates of the fruit and the carrier liquid. It is also interesting to note the similarity between liquid and particle P-values; the ohmic control panel displayed P-values of 90-100 minutes compared with 52-159 minutes measured with the TTI particles. These P-values were unlikely to represent true P-values for the complete system because liquid P-values were calculated from the temperature sensor at the ohmic

column outlet (using Equation 4.6) whereas particle P-values were from TTI particles that travelled the complete heating, holding and cooling sections (using Equation 4.5). It was not possible to calculate both P-values for the complete heat-hold-cool process because of uncertainties of liquid temperatures within the heat and cool parts of the process.

Pineapple

For the pineapple trial, five TTI cubes were retrieved from the product/starch interface. Starch was used to push the product through the system in order to recover the maximum quantity of saleable product. All other TTI particles were retrieved within the pineapple mixture. These five P-values do not appear in the distribution of P-values presented in Figure 4.17 because they may not have heated at the same electrical rate as those in the fruit carrier liquid. As with the blackcurrants, the results for the pineapple pieces showed a wide range of P-values. For a reference temperature of 85°C, the highest P-value achieved was 168 minutes and the lowest was 18 minutes. The factory control panel showed an average P-value of 99 minutes: a value representative of the liquid.

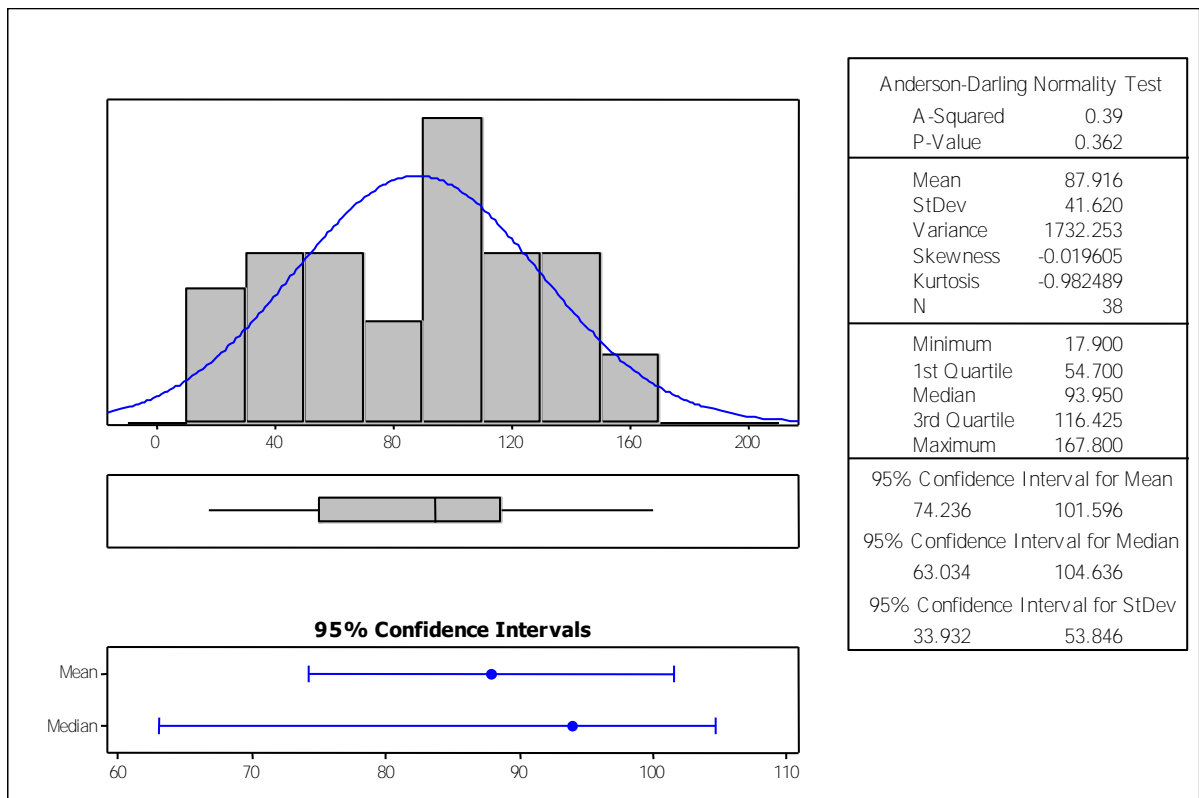

Figure 4.17: Frequency distribution for 10 mm silicone TTI cubes representing 12 mm pineapple pieces in a pineapple fruit preparation, processed in a 75 kW ohmic heater at $750 \text{ kg}\cdot\text{h}^{-1}$. Sample size 38. Explanation of the graphs is given in Chapter 2 section 2.8.

The frequency distributions in Figures 4.16 and 4.17 are very different in shape to that measured from the tubular heat exchanger in Figure 4.13. The distributions with the ohmic heated blackcurrant and pineapple products showed proportionally more high P-values than with the tubular data, and also a sharper lower P-value cut-off. These effects were likely to be caused by instantaneous electrical heating of particles within the ohmic column that could raise the temperature of all particles to similar levels. Slow tubular cooling could subsequently cool the particles at different rates within the tubes and thus result in the tailing of distributions in Figures 4.16 and 4.17.

An additional effect that could affect the P-value distribution was the increase in temperature along the holding tube, which was approximately 7°C for both blackcurrant and pineapple products. The magnitude of this temperature increase varied from 5 to 10°C for different fruit products. It depended on factors such as particle concentration, relative electrical

conductivities of the liquid and particles, ohmic column exit temperature and flowrate.

Historic data from this ohmic plant showed that smooth products such as fruit purees showed no temperature rise in the holding tube whereas products with large particles commonly showed rises of 6 to 8°C.

The particle residence time distribution through the heating and holding tubes also differed from that expected with tubular heat exchangers (Tucker and Withers, 1992). This is a viscosity effect caused by particles that are hotter than the surrounding liquids for ohmic heating systems compared with the reverse situation with a tubular or conventional conduction controlled heat exchanger. This results in differences in liquid viscosity at particle surfaces and consequently in particle slip velocities. Conventional tubular heating results in high viscosity liquid layers adjacent to the colder particle surfaces. However, particle surfaces in ohmic heating rise rapidly in temperature which result in hot liquid surrounding the particles; this creates low viscosity liquid layers around the particles. The net result is that particles in an ohmic system may not be as restricted in their movement as with a tubular heat exchanger.

P-value results from the TTI particles shown in Figures 4.16 for blackcurrant and 4.17 for pineapple were greater than the target P-value of 5 minutes at 85°C. TTI P-values represented heat transfer into silicone TTI particles by conduction heat transfer and did not receive any electrical heating effects, and therefore they erred on the safe side. Considerable scope thus exists for optimising the ohmic processes by operating to lower column exit temperatures through, (i) reducing the ohmic column power output or, (ii) operating at higher flowrates. Process optimisation of the same ohmic heater is considered in the next case study.

4.5.3 Case Study 7: 400 kg batch of diced strawberries processed in a 75 kW ohmic column

The objective of the process optimisation trials were to establish microbiologically safe operating limits for the 75 kW ohmic column by challenging the settings until TTI P-values fell below the process targets. The experiments involved increasing the process flowrate at constant power. The product was a 400 kg batch of 10-12 mm diced strawberry, which were represented by TTI particles of 10 mm cubes containing the amylase solution at their centres. A single 400 kg batch was sufficient to evaluate four sequential increases in flowrate, starting

with the normal production rate of 750 kg.h^{-1} and working upwards to over $1,000 \text{ kg.h}^{-1}$ (see Table 4.4 for details of the flowrates and the TTI particles introduced).

Two different amylases were used; BAA85 and BLA90. The amylase used for the first three runs was BLA90, because it was expected that the TTI P-values would be substantially higher than the microbiological target of 5 minutes at 85°C . However, in the final run at the highest flowrate of $1,000 \text{ kg.h}^{-1}$, both amylases were used, because it was thought that this flowrate would challenge the microbiological safety for the product. Therefore, both types of TTI were used, with 20 of the TTI particles containing BLA90 and 20 containing BAA85. This ensured a better chance that the residual amylase activities from the processed TTIs were within the measurable range for these TTI systems. Both amylases showed similar temperature sensitivity in that z-values for were similar; with z for BLA90 at 9.1°C and for BAA85 it was 9.4°C .

TTI particles were introduced to the flowing fruit product by a dosing tube and plunger system. This ensured they entered the fruit product prior to the pump, and were drawn into the pump chamber during the next suction stroke of the piston. Mixing TTI particles into the feed tank would not have provided a guarantee of when they entered the system, and so was not appropriate for this trial. The dosing tube enabled the TTI introduction to be controlled so that the TTI particles experienced the required flowrate conditions. For example, in the first trial at 750 kg.h^{-1} , all 30 TTI particles were dosed into the vessel outlet together so that they travelled through the ohmic column and holding tube while the flowrate was 750 kg.h^{-1} . Once sufficient time had elapsed for the TTI particles to exit the holding tube, the flowrate was increased and another batch of TTIs introduced.

TTI particles were marked with different colour crosses so they could be identified as being from a specific flowrate condition. They were recovered by spreading the fruit onto sorting trays and going through by hand. This method was time consuming but proven with previous continuous processing work to be the most effective means of recovering TTI particles from large batches of food products.

Table 4.4: Details of processing conditions for each run of the ohmic trial with 12 mm diced strawberries.

	Flowrate (kg.h⁻¹)	Details of TTI particles added to the feed batches
Run 0	750	30 BLA90
Run 1	750 - 800	20 BLA90
Run 2	815 - 850	20 BLA90
Run 3	1,015 – 1,050	20 BLA90 + 20 BAA85

(i) Run 0; Flowrate 750 kg.h⁻¹

Run 0 was the baseline flowrate of 750 kg.h⁻¹, which was the flowrate used for most factory production runs. 22 out of 30 of the TTI particles were recovered and all of the TTI particles showed they had been processed substantially in excess of the target of 5 minutes equivalent at 85°C. Figure 4.18 (a) shows the P-value distribution in Run 0. Measured P-values from the BLA90 TTIs ranged from 62 to 195 minutes equivalent at 85°C.

However, it was expected that the lowest P-value of 62 minutes was not a true value because of cross contamination of low activity amylase samples with unheated amylase of higher activity. Procedural changes for extracting amylase solution from the TTI tubes/particles were introduced following this strawberry trial; these are discussed in Chapter 2.

(ii) Run 1; Flowrate 750 to 800 kg.h⁻¹

Experimental complications were experienced in operating the ohmic column at flowrates greater than 750 kg.h⁻¹ because of the excessive current required to maintain the column exit temperature. In order to achieve the exit holding tube temperature at the higher flowrates for Runs 1 to 3, plant settings for the voltage : current ratio on the column were changed. This was necessary because the ohmic column was operating close to its maximum current density for flowrates over 750 kg.h⁻¹.

Achieving a stable flowrate in Run 1 was difficult, and it ranged from 750 to 800 kg.h⁻¹. In Run 1, 18 out of the 20 TTI particles were recovered and all showed P-values that exceeded the target process. P-values measured with the BLA90 TTIs ranged from a lowest value of 33 minutes to 164 minutes, with the distribution given in Figure 4.18 (b).

(iii) Run 2; Flowrate 815 to 850 kg.h⁻¹

An increased flowrate in Run 2 of between 815 and 850 kg.h⁻¹ was achieved by accepting a lower column exit temperature within the ohmic control panel software. The factory control panel indicated that the P-values remained above 6 minutes during the run, and therefore the carrier liquid was safely processed. P-values measured with the BLA90 TTIs ranged between 12 minutes and 135 minutes, with the distribution given in Figure 4.18 (c).

(iv) Run 3; Flowrate 1,010 to 1,050 kg.h⁻¹

The flowrate was increased in Run 3 to between 1,010 and 1,050 kg.h⁻¹, which was achieved by allowing the ohmic exit temperature to fall below 95°C. The P-value display on the control panel dropped to below 3 minutes, which indicated that the carrier liquid within the holding tube did not receive sufficient pasteurisation. Results from the BLA90 TTI particles gave P-values between 5 and 38 minutes, however, the relatively high heat stability of the amylase at 85°C meant that these P-values were achieved with only a small percentage of activity lost. This was the least accurate part of the measurement and so the BLA90 results were not used in Figure 4.18 (d). More reliable results were measured by the BAA85 TTI particles that gave P-values ranging from 5 to 11 minutes, with the distribution given in Figure 4.18 (d). Residual amylase activity from the BAA85 TTI particles was in the range where one to two log reductions in activity were measured. This resulted in more accuracy in activity readings than with the BLA90 TTI particles that reduced in activity by less than one log reduction. The lowest P-values from BAA85 measurements were close to the target of 5 minutes, which indicated that the product was adequately processed but there was no process margins to allow for minor fluctuations in flowrate or electrical energy input

(a)

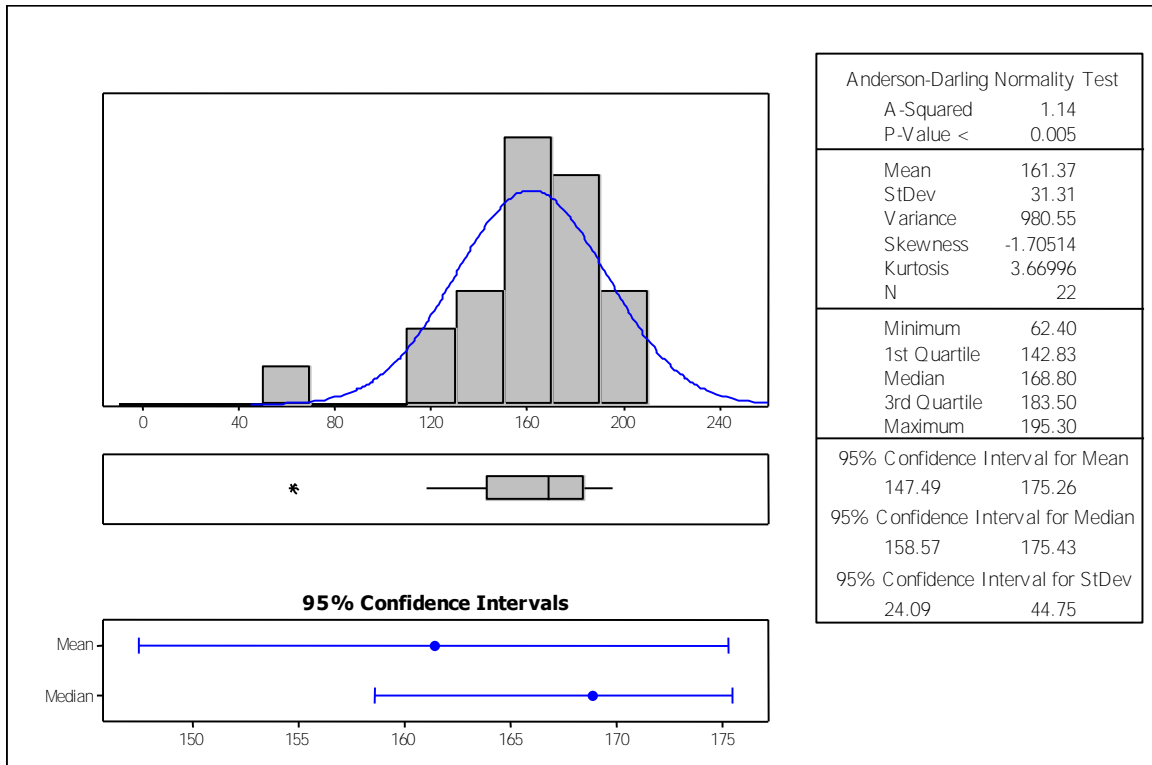

(b)

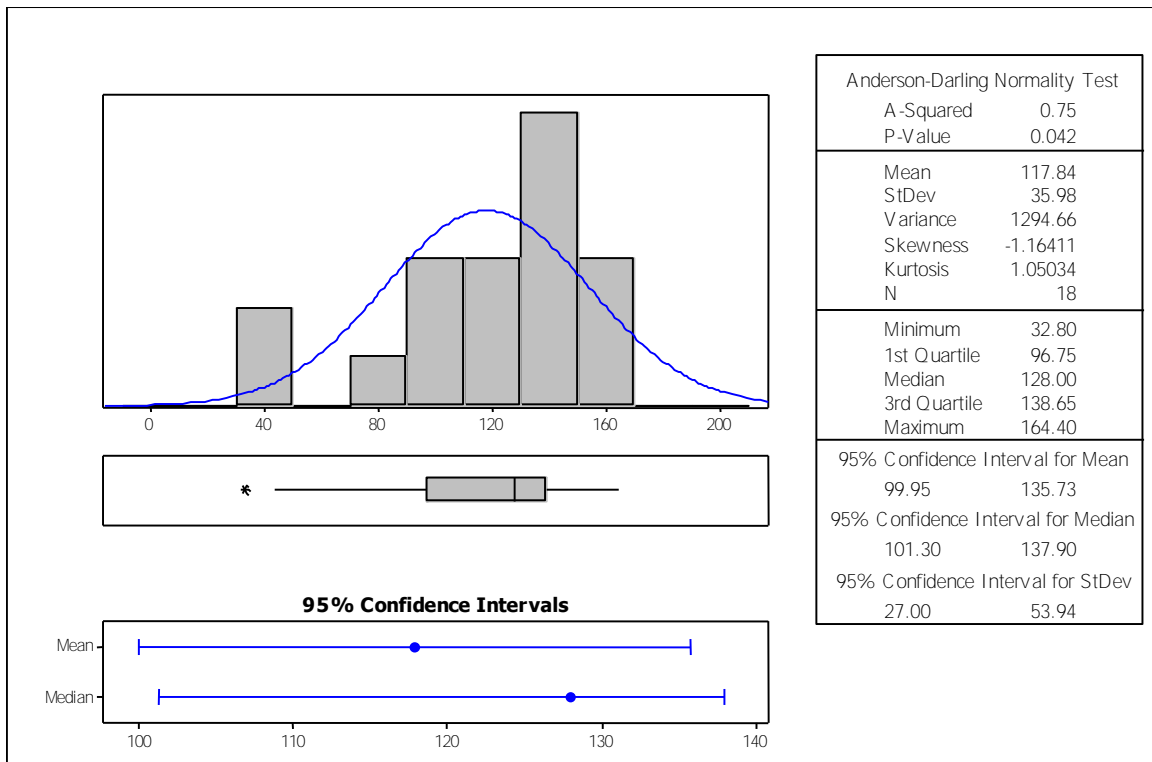

(c)

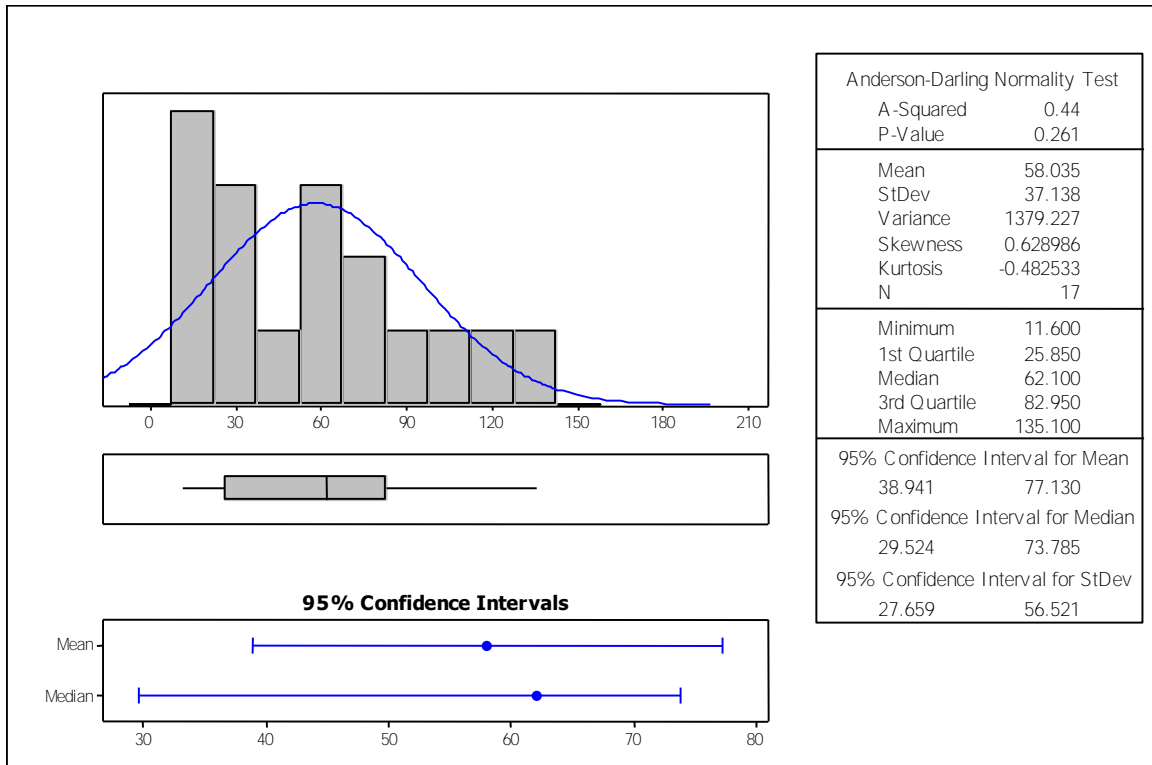

(d)

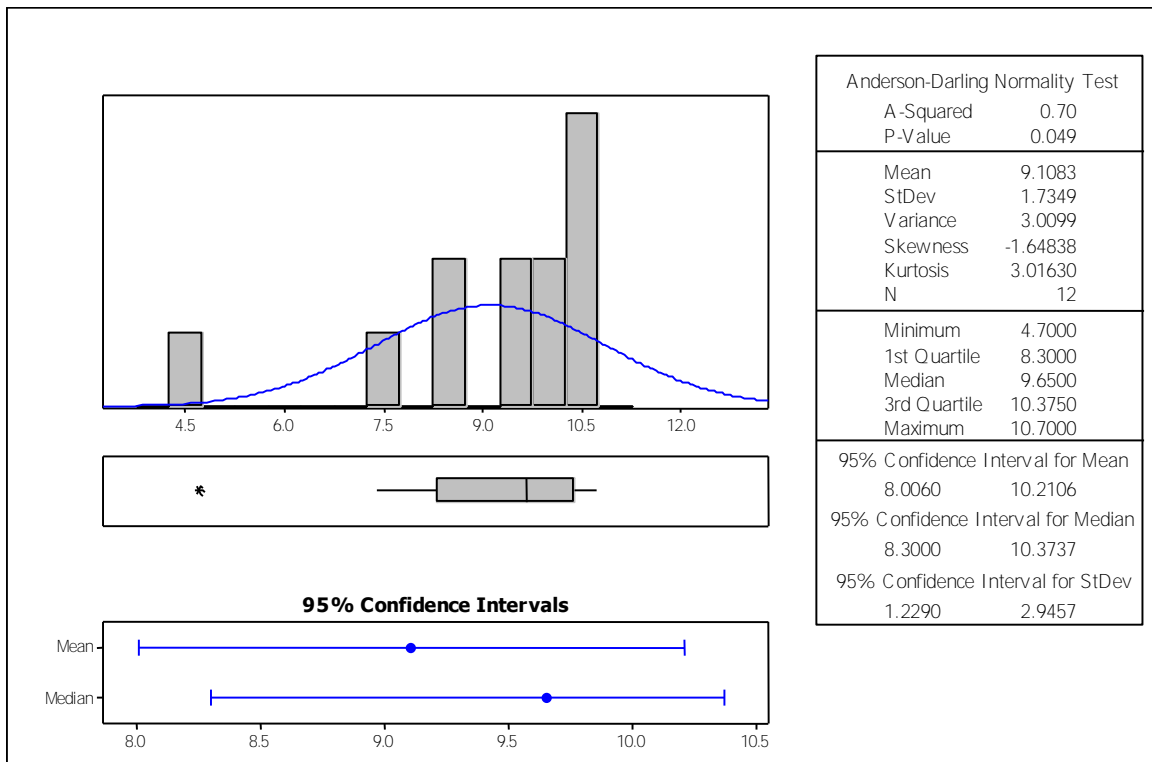

Figure 4.18: Frequency distribution for 10 mm TTI cubes representing 12 mm strawberries in diced strawberry processed in a 75 kW ohmic heater. Run 0 at 750 kg/h, (b) Run 1 at 750-800 kg/h, (c) Run 2 at 815-850 kg/h, (d) Run 3 at 1,015-1,050 kg/h.

Table 4.5 presents minimum, maximum and mean P-value from each of the four process optimisation trials. It shows a gradual decrease in P-values as the flowrate increased from the normal production value of 750 to 1,050 kg.h⁻¹. Figure 4.19 illustrates the data from Table 4.5 to illustrate the relationship between TTI particle P-value and flowrate.

Table 4.5: Minimum, maximum and mean P-values from 10 mm TTI particles in the 75 kW ohmic heater at flowrates of 750 kg.h⁻¹ (Run 0) to 1,050 kg.h⁻¹ (Run 3). Reference temperature was 85°C and z 9.1°C for BLA90 and 9.4°C for BAA85.

Flowrate (kg.h ⁻¹)	Run 0 750	Run 1 750-800	Run 2 815-850	Run 3 1,015-1,050
Minimum P-value	117.9	32.8	11.6	4.7
Maximum P-value	195.3	164.4	135.1	10.7
Mean P-value	166.1	117.8	58.0	9.1

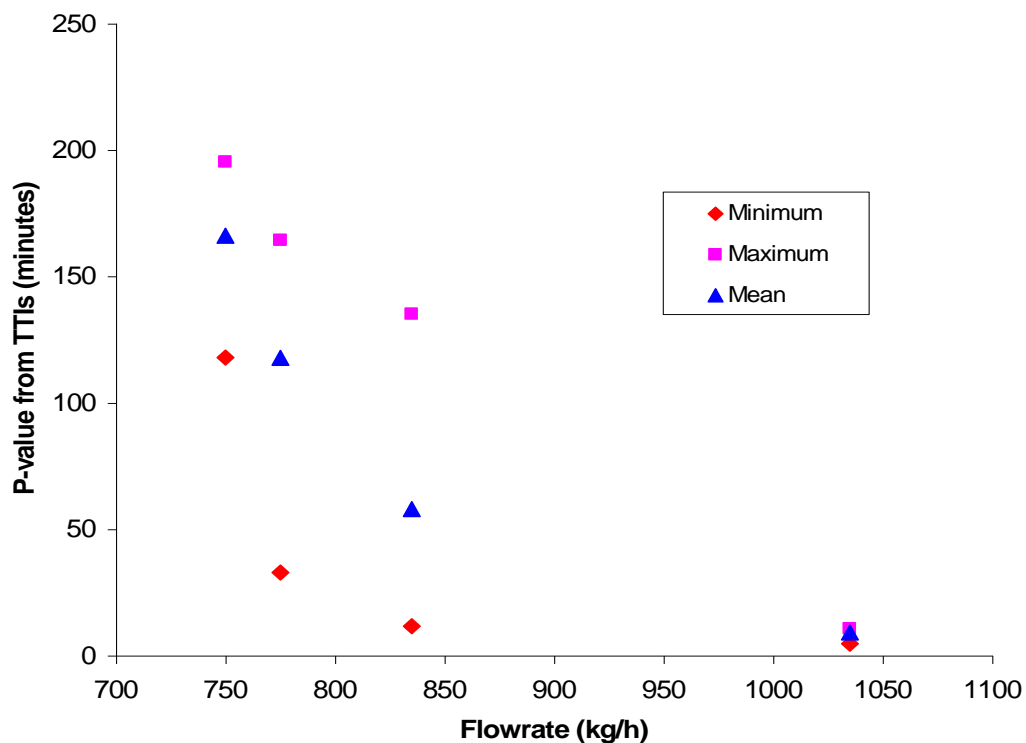

Figure 4.19: Minimum, maximum and mean P-values from 10 mm TTI particles in the 75 kW ohmic heater at flowrates of 750 to 1,050 kg.h⁻¹.

Reference temperature was 85°C and z 9.1°C for BLA90 and 9.4°C for BAA85.

These process optimisation trials identified flowrates that gave acceptable P-values for processing of fruit particles. Flowrates up to 850 kg.h⁻¹ provided sufficient margin above the lower P-value limit for the 10 mm particles. Operating the 75 kW ohmic heater at 1,050 kg.h⁻¹ did not allow sufficient operational margin to allow for variability in critical parameters that affect P-value, for example, electrical conductivity of fruit and carrier liquid, flowrate, initial fruit temperature, electrical current.

If flowrates above 850 kg.h⁻¹ need to be achieved, the results suggest that the 75 kW ohmic column will struggle to deliver sufficient electrical energy to the products without changing the configuration. The simple solution would be to increase the hold tube length from the existing 16.4 metres to increase the residence time and thus the P-value for both carrier liquid and fruit particles.

4.5.4 Case Study 8: Two 850 kg batches of nectarine & orange processed in a 75 kW ohmic column, hot-filled into 8.5 kg plastic bags

The objective of this TTI trial was to measure P-values on the inside surfaces of hot-filled plastic bags. Fruit product was heated through the 75 kW ohmic column and filled hot into bags. Residual heat from the hot fruit was intended to pasteurise the inside bag surfaces (CCFRA, 1992).

Pergal bags are one of the commercial packaging formats used for the types of fruit preparations described here. They are plastic bags (typically holding 8.5 to 15 kg of fruit) with a plastic stopper that creates an hermetic seal. These bags are used as an intermediate sized package for fruit intended for inclusion as an ingredient in yoghurts or desserts. They allow manufacturers of yoghurts and desserts, as well as catering establishments, the opportunity to prepare small quantities of finished products without the wastage that would otherwise occur if the fruit was delivered in a 400 kg tank.

Fruit products intended for filling into Pergal bags are usually pasteurised in 1,000 kg stirred vessels and are then hot-filled. Cooling takes place in the bag, which is slow due to the relatively large volumes in each bag. Figure 4.20 shows the schematic layout of the ohmic plant.

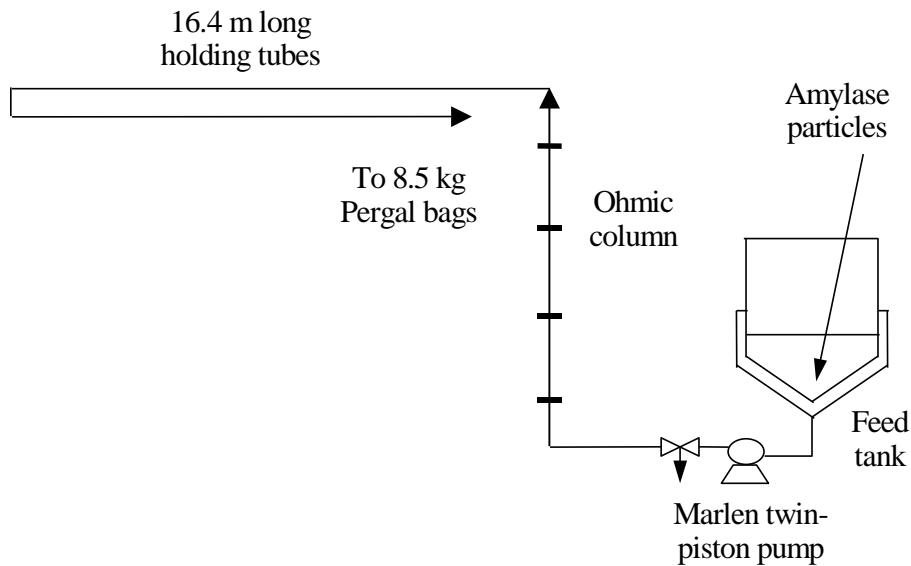

Figure 4.20: Schematic of a hot fill into 8.5 kg bags fed directly from a 75 kW ohmic column.

Issues to resolve with the process were (i) to measure the levels of pasteurisation for the fruit pieces as they flowed through the ohmic heater using TTI particles, and (ii) to measure the pasteurisation achieved at the inside bag surfaces using TTI tubes. With hot-filled products, any microbiological contamination on the inside package surfaces relies on residual heat within the products to effect pasteurisation.

The test product was an 850 kg batch of nectarine and orange fruit preparation. Fruit particles were 12-15 mm diced nectarines. The orange component of the product was juice. TTIs were divided into four groups for this trial to evaluate the effect of four different hot fill temperatures from 80 to 89°C. One 850 kg batch of nectarine and orange fruit preparation was sufficient to test four different hot filling temperatures. Four runs were completed at fill temperatures of approximately 80, 83, 86 and 89°C; these temperatures were required at the Pergal bag filler. Flowrate used throughout the trial was 750 kg.h⁻¹.

Time taken for the TTI cubes to pass through the ohmic column and 16.4 metre hold tube was calculated at 180 seconds minimum and 360 seconds average. These calculations assumed laminar flow and the centreline velocity of double the mean velocity. Once the TTIs had reached the end of the hold tube (according to the mean residence time calculation), the set

point temperature of the column was increased by adjusting the column control settings in order to draw more electrical power (success of this control method is discussed later). When the ohmic column had stabilised at this new temperature, the next set of TTIs were introduced to the feed tank using the dosing system as described in section 4.5.4. The best efforts to control fill temperature to 3°C increments between 80 and 89°C resulted in hot fill temperatures accurate to approximately $\pm 1^\circ\text{C}$.

TTI tubes were prepared by injecting 15-20 μL of BAA85 into the centre of each tube and capping the tubes with Sylgard 184 elastomeric compound. Sixty TTI tubes were incorporated into the centres of 10 mm silicone cubes that represented the 12-15 mm pieces of nectarine. Batches of fifteen TTI cubes were marked with different colour crosses so they could be identified as being processed by different hot-fill temperatures. Fifty TTI tubes were used for surface P-value measurement. For the BAA85, the kinetics were represented by a decimal reduction time of 6.8 minutes at 85°C and a z of 9.4°C. These TTIs were suitable for this high acid fruit product with a target process of 5 minutes at 85°C with a z of 10°C.

TTI tubes were secured to the inner layer of the Pergal bags in groups of twos and threes, positioned in the corner and at the filling nozzle. These were the positions where the residual heat from the hot product was considered to be lowest and/or the thermal mass of plastic was greatest. Bag corners were likely to cool fastest and therefore deliver the least pasteurisation. Pergal bag nozzles contained substantially more plastic than the relatively thin bags themselves, and so were likely to absorb heat from the hot fruit. TTI tubes were attached at these locations using adhesive tape. Two Pergal bags containing TTI tubes were used for each hot fill temperature.

Fifteen TTI cubes were put through the ohmic process at each of the different fill temperatures to estimate the fruit particle P-values. The first column operating temperature was 80°C. Fifteen TTI cubes were introduced to the outlet pipe of the feed tank to ensure they exited the feed tank at the same time and were processed at the same operating temperature.

After hot filling and blast chilling to a temperature low enough for handling the fruit, the Pergal bags were opened and the fruit sorted by hand to recover the TTI cubes from the fruit, and the TTI tubes from the inside bag surfaces. All but one of the TTI cubes were recovered. Recovery of the TTI cubes required each Pergal bag to be opened and the 8.5 kg contents

spread onto fruit sorting trays. Cubes from each operating temperature were kept in chilled water at 5-8°C, in pots labelled with the appropriate fill temperature.

Two of the TTI cubes from the 89°C trial were damaged during the amylase extraction procedure and so could not be analysed. Table 4.6 presents P-values results from individual TTI cubes, calculated using a D-value for BAA85 of 6.8 minutes. These showed that the 80±1°C ohmic column temperature was insufficient to pasteurise the fruit particles to the target of 5 minutes at 85°C. However, with the column operating at 89±1°C, both fruit particles and inside bag surfaces received an adequate pasteurisation. Results from column temperatures of 83±1°C and 86±1°C were not conclusive for bag surface pasteurisation; it was thought that was because temperature control might not have been within ±1°C.

Despite the uncertainty with TTI results for column temperatures of 83±1°C and 86±1°C, in all cases, groups of TTIs inside Pergal bags gave consistent results within that group. For example, at a hot fill temperature of 83 ±1°C the groups of two TTIs gave P-values of 5.7 to 5.9 minutes and 5.1 to 6.0 minutes, and the groups of three TTIs gave P-values of 5.3 to 6.1 minutes and 4.9 to 9.5 minutes (see Table 4.7). The latter grouping of three TTIs showed a wider spread of P-values but these were still realistic values. Closeness of the P-values within a group of TTI tubes gave further confidence that the TTI P-values were correct.

Table 4.6: P-values results from individual TTI particles, representing 12-15 mm diced nectarines, calculated using a D-value for BAA85 of 6.8 minutes.

TTI number	Hot fill temperatures			
	80°C	83°C	86°C	89°C
1	4.3	9.6	8.7	8.7
2	1.4	9.6	8.7	9.9
3	2.0	11.7	8.7	8.7
4	1.3	9.6	12.0	7.9
5	3.5	9.6	9.9	12.0
6	7.6	6.4	9.9	12.0
7	6.4	8.4	8.7	9.9
8	8.4	9.6	9.6	9.9
9	8.4	6.9	11.7	8.7
10	5.9	8.4	11.7	6.2
11	6.9	9.6	9.6	8.7
12	9.6	9.6	8.4	8.7
13	11.7	-	9.6	8.7
14	9.6	-	11.7	-
Minimum	1.3	6.4	8.4	6.2
Maximum	11.7	11.7	12.0	12.0
Average	6.2	9.1	9.9	9.2

Table 4.7: P-values results from TTI tubes attached to the inside surface of the Pergal bags, calculated using a D-value for BAA85 of 6.8 minutes.

Hot fill temperatures	Group of 2 TTIs	Group of 2 TTIs	Group of 3 TTIs	Group of 3 TTIs
80	1.0	0.0	1.9	0.0
	0.0	0.0	2.4	2.1
			0.0	0.0
83	5.7	6.0	6.1	9.5
	5.9	5.1	5.5	4.9
			5.3	6.4
86	0.2	0.0	0.3	0.0
	0.1	0.3	0.0	4.7
			0.8	2.8
89	5.4	6.9	6.2	6.1
	6.5	5.9	7.2	8.8
			5.5	6.1

The single 850 kg batch of fruit product was sufficient to allow four incremental increases in ohmic column temperature to be studied. Achieving a stable and controlled fill temperature was difficult. Temperature control acted within the column whereas the temperature at the point of filling was the critical temperature for achieving surface bag pasteurisation. Product temperature at the ohmic column outlet was actually close to that at the point of filling. This was achieved by coincidence rather than design. Fruit pieces that heated electrically gave up heat in the hold tube to the surrounding carrier liquid, which resulted in measured temperatures at the hold tube exit some 5-7°C higher than at the entry. Once equilibrated, the fruit product subsequently cooled by 2-3°C during the 5 metre pipe to the filler bowl and

further cooled by 3-4°C in the filler bowl and during filling. The overall effect was that the ohmic column outlet temperature was almost the same as at the point of filling.

Adjusting the (heat capacity value) control panel to change the hot fill temperature required some manipulation. Therefore, the column required time to stabilise in response to each change in heat capacity. This resulted in gradual increases in product temperature within the fruit product filled off at each different temperature at the filling machine. The indirect means of temperature control prevented the exact temperature targets of 80, 83, 86 and 89°C from being achieved. However, as described earlier, it was possible to achieve a similar filling temperature to that measured at the column outlet.

Conclusions from this optimisation study were:

- With a filling temperature (column outlet temperature) of 80±1°C neither the fruit product nor the packaging received an adequate pasteurisation of 5 minutes equivalent at 85°C.
- At 83±1°C, the P-values from TTI tubes in the Pergal bags all measured greater than 5 minutes at 85°C, except for one TTI at 4.9 minutes. TTI cubes processed with the fruit exceed 5 minutes at 85°C.
- At 86±1°C, TTI tubes in the Pergal bags suggested very low levels of surface pasteurisation, with P-values lower than those measured at the 83±1°C filling temperature. These seemed inconsistent and might have been caused by the variability in ohmic column outlet temperature. TTI cubes processed with the fruit exceed 5 minutes at 85°C.
- At 89±1°C, all of the TTIs inside the bags and in the fruit product received an adequate pasteurisation of 5 minutes equivalent at 85°C. It was concluded that a fill temperature of 89±1°C was high enough to achieve the target pasteurisation with sufficient operating margins.

4.6 Discussion of results and findings from the industrial trials

Experimental techniques in applying different types of TTIs to industrial processes evolved over the series of trials described in this chapter. The stage was reached in which zero TTI particle damage occurred within fruit processing equipment and 100% recovery of TTIs was achieved on many occasions. Encapsulating the amylase solution in 2.5 mm diameter silicone tubes proved an important step forwards. This provided a robust system that allowed the tubes filled with amylase solution to be used directly with the food or incorporated into larger silicone food particles. Towards the later stages of this research, these silicone particles were made with a black silicone compound incorporated as a bottom layer in order to make identification easier. These multi-layered TTI particles were as strong as those from a single silicone compound.

The key step in making the TTI method one suitable for use in complex industrial processes was in the encapsulation of amylase solutions. This has evolved with industrial experience of successes and some failures, and has been applied to improve numerous thermal processes. Examples from a fruit processing factory were given in this chapter to illustrate how this can work.

Many challenges were addressed in ensuring the TTI method was applicable to food manufacturing operations. However, they can be summarised in the following three needs, which are to:

- (a) Introduce TTIs to complex processing systems in a way that represents the distribution of food particles in the preparation step,
- (b) Ensure the TTIs heat and flow in the same way as the critical food particles, without incurring damage to the TTIs,
- (c) Recover all of the TTI particles intact.

Data generated from the TTI trials described in this chapter were invaluable for optimising fruit product manufacture. This was demonstrated in a variety of industrial equipment including mixing vessels, a tubular heat exchanger, hot-filling operations, and in an ohmic column. Most fruit processes measured with TTIs showed very high levels of pasteurisation at normal production throughputs. This gave scope for processes to be optimised so that

production efficiency was increased and in some cases product quality improved. The latter was achievable for processes in which the heating took place with high shearing conditions such as mixing vessels. In general, it was the increases in production efficiency that drove the factory needs for process optimisation.

4.6.1 Future needs

Despite the improvements in TTI recovery, it would still be convenient to develop a fast and reliable method to recover TTI particles from large volumes of food products. Hand sorting was demonstrated to work but takes time and requires the TTI test to be destructive for the food product. Incorporation of a (mildly) radioactive particle into a TTI tube or TTI particle may allow the use of a Geiger counter for their detection. This has not yet been attempted because of the concerns about residual radioactivity in a food processing environment. Work with the positron emission particle tracking system (PEPT) at the University of Birmingham has used micron sized glass particles with low levels of radioactivity. These may be suitable and provide an alternative TTI particle recovery method.

**CHAPTER 5: A NOVEL STERILISATION TIME-TEMPERATURE INTEGRATOR
BASED ON AMYLASE FROM THE HYPERTHERMOPHILIC MICROORGANISM
*PYROCOCCUS FURIOSUS***

"If we knew what we were doing then it would not be called research".

Albert Einstein

5.1 Introduction

Chapters 1 to 3 describe the range of amylase-based TTIs suitable for measuring P-values with most commercial pasteurisation processes. These range from a few minutes at 70°C up to many minutes at 95°C. However, attempts to manufacture an enzyme-based TTI to survive a full sterilisation process at 121.1°C for several minutes have had limited success when applied to industrial situations (Van Loey et al., 1997b). Chapter 1 provides details of the minimum thermal requirements for a full sterilisation process. These are substantially higher than for pasteurisation treatments and will result in all amylase activity being lost before the TTI temperatures increased much above 100°C. Hence, it is not surprising that a TTI solution has not yet been discovered.

Amylase does appear to be one of the few enzymes that exhibits suitable properties for use as a TTI to mimic microbiological death kinetics, but only for pasteurisation. Specifically, the measured z-values for different amylases have been in the range 9 to 10°C, ideal for bacterial spore destruction (De Cordt et al., 1992 and 1994; Maesmans et al., 1994; Hendrickx et al., 1995). Hence, an amylase was considered to provide the greatest chance of finding a TTI for use in sterilisation processes. Extension of the useable range upwards into sterilisation temperatures has been demonstrated by drying commercial grade amylases to precise moisture levels (Van Loey et al., 1997b, Guiavarc'h, 2003). Results achieved in the laboratory were encouraging and showed that different levels of moisture content gave a range of heat stabilities.

One approach immobilised a mixture of *Bacillus licheniformis* α -amylase (BLA), sucrose and salts at the surface of non-porous glass beads (inert filler), and under several low moisture conditions (a_w in the range 0-0.63 after equilibrium at 4°C (Guiavarc'h et al., 2004a). These systems showed potentially useful thermal stabilities in the range 100-132°C under isothermal and non-isothermal conditions. Residual amylase activity was used, instead of a residual heat denaturation enthalpy reading, as the response property of the system. This had advantages in reduced assay times and reduced amounts of amylase were required per TTI (50-fold smaller). Thermal processes up to 30 minutes at 121.1°C could be monitored.

A similar approach was taken by Samborska et al. (2005) who reduced moisture content to enhance thermal stability of *Aspergillus oryzae* α -amylase. The enzyme was mixed with maltodextrin and freeze dried after equilibration above saturated salt solutions to achieve moisture contents from 3.5 to 0.029 g H₂O/g dry wt.. Thermal inactivation kinetics of the enzymes were then determined. Results were compared with those obtained using the enzyme mixed with aqueous solutions of maltodextrin. In general, the α -amylase showed greater thermal stability in maltodextrin systems at reduced moisture content than in aqueous solutions. Decreasing the moisture content from 3.5 to 0.029 g H₂O/g dry wt. led to an increase in the temperature at which inactivation of amylase occurred, increasing it from 70-75 to 100-115°C. The activation energy (related to z-value) of thermal inactivation was also affected by moisture content. Despite reducing the moisture content, the levels of heat stability for *Aspergillus oryzae* α -amylase were insufficient for use as a sterilisation TTI.

Guiavarc'h et al. (2002 and 2004b) again used *Bacillus licheniformis* α -amylase, but equilibrated at 81% equilibrium relative humidity at 4°C (BLA81). Isothermal and non-isothermal conditions were used to determine heat denaturation kinetics by monitoring the decrease in enthalpy associated with the heat denaturation of the enzyme. Due to its low water content, BLA81 denaturation could be studied in the range of 118-124°C. Two batches of BLA81 were successfully validated under non-isothermal conditions allowing the determinations of process values (reference temperature of 121.1°C) in the range of 1-15 minutes. BLA81 was used as a TTI to investigate potential differences of process values received by freely moving spherical particles as compared to a centrally fixed particle (single-position impact) inside cans containing water as brine. Interesting results showed the process value received by freely moving particles to be from 5.6% (4 rpm) to 19.7% (8 rpm) smaller

than those with centrally fixed spheres. This study highlighted the potential of the TTI technology to monitor the safety of heat-processed agitated solid/liquid foodstuffs.

However, other researchers (Tucker, 2003; Tucker and Wolf, 2003) encountered experimental difficulties in controlling the sterilisation TTI based on the dried amylase approaches of Van Loey et al. (1997b) and Guiavarc'h, (2003). Heat stability was increased by drying the amylase in a steel DSC (differential scanning calorimeter) capsule, and the same capsule was used for measuring process values. This had the advantage that, once sealed, the capsule did not have to be opened during the heating tests or for analysis. However, the encapsulation method did not provide adequate isolation from its environment when used in industrial sterilisation processes because the rubber O-ring gasket was unable to withstand the swings in pressure experienced within a food container during a sterilisation process. It was possible to encapsulate the DSC capsule in a silicone compound that prevented moisture ingress but this resulted in dimension changes to the TTI particle (Van Loey et al., 1997b and Guiavarc'h, 2003). For some products with large particles this was acceptable but for most it negated the purposes of conducting process validation studies using TTIs. One further issue with the steel capsules was their high density that prevented their use in flowing foods.

Thus, a different method was required for a sterilisation TTI, with ideally, a TTI system that allowed the TTI to be used as a solution within the silicone TTI tubes already proven in industrial pasteurisation processes (see Chapters 2, 3 and 4). This was a substantial challenge that required a novel solution.

The idea developed in this chapter was to locate a microorganism that has evolved in hostile conditions of temperature, yet was reported to be an amylase producer. Of the millions of types of microorganisms found in nature, this narrowed the search to just a few of extreme durability. The challenge was to grow this microorganism, extract the amylase and apply it in its native form to industrial sterilisation processes. The logic was that the amylases produced by these extreme microorganisms must be able to withstand high temperature conditions, otherwise their structure would break down before they started work in breaking down complex starches and carbohydrates to sugars.

Microorganisms are known to exist in hostile environments such as volcanic pools where they have adapted to high temperature conditions and to chemical environments considerably

different to those favoured by the microorganisms we are more familiar with (Seegerer et al., 1993; Stetter, 1996). These 'hyperthermophilic' microorganisms represent a relatively new area for microbiological research and one with enormous potential for supply of heat stable enzymes (Sterner and Liebl, 2001).

Hyperthermophilic microorganisms were one possible and promising route to finding a source of thermostable amylase. Amylases from these microorganisms must be inherently heat stable in order to hydrolyse starches in their favoured environmental conditions (Laderman et al., 1993; Leuschner and Antranikian, 1995; Niehaus et al., 1999; Vieille and Zeikus, 2001). This might allow an amylase solution to be developed with heat stability sufficient to operate in the sterilisation arena: that is to mimic the destruction of *Clostridium botulinum* spores.

A number of bacteria capable of growing at or above 100°C have been isolated from several geothermic terrestrial and marine environments (Vieille and Zeikus, 2001). Among the many interesting features associated with these bacteria are their ability to grow and carry out biological functions at normally protein-denaturing temperatures. The enzymes that are formed by these extremely thermophilic and hyperthermophilic microorganisms are of great interest due to their thermostability and optimal activity at high temperatures. The following paragraphs describe some of the relevant papers.

A novel heat stable enzyme, α -amylase-pullulanase, produced by *Clostridium thermohydrosulfuricum* E 101-69 was purified by Melasniemi (1987; 1988). Melasniemi and Paloheimo (1989) later produced an α -amylase-pullulanase gene from *Clostridium thermohydrosulfuricum* DSM 3783 by cloning it in *Escherichia coli* on a 7.0 kb EcoRI fragment using a lambda vector. The gene produced active thermostable α -amylase-pullulanase, which was mostly a soluble intracellular enzyme in *E. coli*. The apparent temperature optimum of the enzyme was 80-85°C and the heat stability was the same as that of the extracellular α -amylase-pullulanase produced by the native host.

Another hyperthermophilic microorganism reported to produce α -amylase was *Sulfolobus solfataricus* (Worthington et al., 2003). *Sulfolobus solfataricus* secreted an acid-resistant α -amylase during growth on starch as the sole carbon and energy source. This microorganism had the advantage of being aerobic and thus was easier to grow than the anaerobic

microorganisms. No data was available on the heat stability properties of the amylase and so *Sulfolobus solfataricus* was not chosen for further investigation in the thesis work.

Several of the most promising microorganisms referred to later are known as archaea. These are defined in the American Heritage Dictionary (2003) as a group of bacteria-like microorganisms comprising a division of the Prokaryotae and usually thriving in extreme environments. Prokaryotae are unicellular organisms lacking a true nucleus and nuclear membrane, with genetic material composed of a single loop of naked double-stranded DNA (Dorland, 2007). Archaea are often classified as a separate domain in taxonomic systems based on similarities of DNA sequences. However, for the purposes here of locating an amylase-producing microorganism, archaea are bacteria that can survive in extreme environments such as high temperatures, and can produce thermostable enzymes. Several microorganisms showed potential.

One of these, a hyperthermophilic archaeon of the genus *Pyrococcus*, strain AL585(T), was isolated from a deep-sea hydrothermal vent located on the East Pacific Rise at a depth of 2,650 m (Barbier et al., 1999). The isolate was a strictly anaerobic coccus with a mean cell diameter of 1 µm. The optimum temperature, pH and concentration of sea salt for growth were 95°C, 7.5 and 30 g/l. Under these conditions, the doubling time and cell yield were 0.5 h and 5×10^8 cells/mL. This strain grew preferentially in media containing complex proteinaceous carbon sources, glucose and elemental sulphur. Sequencing of the 16S rDNA gene showed that strain AL585(T) belonged to the genus *Pyrococcus* and was probably a new species, described as *Pyrococcus glycovorans* sp. nov.

Perevalova et al., (2005) isolated a microorganism from a freshwater hot spring of the Uzon caldera (Kamchatka Peninsula, Russia). They described the microorganism as an obligately anaerobic, hyperthermophilic, organoheterotrophic archaeon, *Desulfurococcus fermentans* sp. nov., strain Z-1312T. The cells were regular cocci, 1–4 µm in diameter, with one long flagellum. The cell envelope was composed of a globular layer attached to the cytoplasmic membrane. Temperature range for growth was 63–89°C, with an optimum between 80 and 82°C; pH range for growth at 80°C was 4.8–6.8, with an optimum at pH 6.0. Strain Z-1312T grew by hydrolysis and/or fermentation of a wide range of polymeric and monomeric substrates, including agarose, amygdalin, arabinose, arbutin, casein hydrolysate, cellulose, dextran, dulcitol, fructose, lactose, laminarin, lichenan, maltose, pectin, peptone, ribose,

starch and sucrose. No growth was detected on glucose, xylose, mannitol or sorbitol. Growth products when sucrose or starch were used as the substrate were acetate, H₂ and CO₂.

Lioliou et al., (2004) described a number of important properties of enzymes produced by the *Thermus thermophilus* genome. This microorganism showed hyperthermophilic tendencies but the interest was in cloning the microorganism and comparing the enzyme properties between the native microorganism and its clone. Enzymes from the cloned microorganism were not only more thermostable but were also more resistant to chemical agents, properties that made them extremely attractive for industrial processes. The genome approach as an alternative method, to producing amylase from the native microorganism, will be discussed later in this chapter.

Uma Maheswar Rao and Satyanarayana (2004) worked with the microorganism *Geobacillus thermoleovorans* MTCC 4220. They studied the effect of polyamines and their biosynthesis inhibitors on the production of hyperthermostable and Ca²⁺-independent α -amylase. The α -amylase was produced in starch-yeast extract-tryptone broth with different polyamines and polyamine biosynthesis inhibitors at 70°C. The cell-free culture filtrates were used in α -amylase assays. During growth, total polyamines in biomass increased until 2 h, and thereafter, decreased gradually. The total polyamine content was very high in the biomass cultivated at 55°C when compared with that of higher temperatures. Enzyme titre enhanced up to 70°C, and thereafter declined suggesting that 70°C was an optimal temperature for amylase production.

An hyperthermophilic bacterium, *Thermotoga maritima* (Blamey and Adams, 1994) was reported to be a strict anaerobe that grows up to 90°C by carbohydrate fermentation. Enzymes produced during metabolism were heat stable. One such enzyme was pyruvate ferredoxin oxidoreductase (POR), which catalyses the oxidation of pyruvate to acetyl-CoA, the terminal oxidation step in the conversion of glucose to acetate. POR was extremely thermostable, with a temperature optimum for pyruvate oxidation above 90°C, and the time for a 50% loss of activity was 15 h at 80°C under anaerobic conditions. Although amylase was not mentioned, this work demonstrated the heat stable properties of an extracellular enzyme from an hyperthermophilic microorganism.

Growth conditions of the extremely thermophilic microorganisms *Thermococcus celer* and *Pyrococcus woesei* were optimised by Blamey et al. (1999). Both archaea were shown to be strictly anaerobic with optimal growth temperatures of 85 and 95°C respectively. Sodium sulphide, not cysteine, was used as a sulphur and reductive capacity source. The addition of elemental S(o) enhanced growth of both microorganisms, with *T. celer* far more sensitive than *P. woesei* to the absence of S(o). *P. woesei* utilised maltose as a carbon source, while *T. celer* was able to use only peptides from yeast extract, peptone and tryptone as its carbon source. The growth of *P. woesei*, but not *T. celer*, was stimulated considerably in the presence of iron, while Co, Ni, Zn, Mo, Mn and Mg were essential trace elements. Both bacteria produced α -amylase.

The capability of utilising carbohydrates in the form of starch as an energy and carbon source is widely distributed among bacteria, fungi and yeast. Thermophilic and hyperthermophilic microorganisms have been found to grow on starch, indicating that they possess starch-degrading enzymes. The enzymes involved in the conversion of starch to low-molecular-weight compounds (glucose, maltose and oligosaccharides) include α -amylase, β -amylase, glucoamylase, debranching enzymes and α -glucosidase. Microorganisms that produce the starch-hydrolysing enzyme α -amylase include *Pyrococcus woesei*, *Pyrococcus furiosus*, *Thermococcus celer*, *Fervidobacterium pennavorans*, *Desulfurcoccus mucosus* and *Termotoga maritima* (Leuschner and Antranikian, 1995). All these microorganisms offer the potential as sources of thermostable α -amylase.

According to Koch et al. (1990 and 1991), *Pyrococcus furiosus* and *Pyrococcus woesei* produced extremely thermostable amylolytic enzymes which were of great interest for industrial applications. Methods for culturing these microorganisms at 100°C and extracting the amylase were given together with data that suggested the amylase heat stability was very close to that required to survive a thermal sterilisation process. These two microorganisms were of the greatest interest for the sterilisation TTI work reported here.

5.1.1 *Pyrococcus furiosus*

Pyrococcus furiosus is an obligate anaerobic, hypothermophilic archaebacterium which has been isolated by Fiala and Stetter (1986) from shallow thermal waters near Vulcano island,

Italy. The motile coccus-shaped microbe, with about 50 flagella at one end, is capable of growth on complex media with or without elemental sulphur. Several relevant papers described growth conditions and certain properties of the extracellular amylases excreted.

Weinberg et al. (2005) grew *Pyrococcus furiosus* on maltose, both near its optimal growth temperature of 95°C, and at the lower end of the temperature range for significant growth at 72°C. In addition, cultures were shocked by rapidly dropping the temperature from 95 to 72°C, which resulted in a 5 hour lag phase, during which time little growth occurred. Driskill et al. (1999) utilised a range of carbohydrates for *Pyrococcus furiosus* growth by examining the spectrum of glycosyl hydrolases produced by this microorganism and the thermal labilities of various saccharides. *P. furiosus* was grown in batch cultures on several α -linked carbohydrates but not on glucose or other α -linked sugars. Significant growth at 98°C occurred.

Savchenko et al., (2002) investigated the role played by metal ions in thermal stability of extracellular α -amylase from *P. furiosus*. They found that this amylase was more thermostable than its bacterial and archaeal homologues (e.g. *Bacillus licheniformis* and *Pyrococcus kodakaraensis* α -amylases) even without adding Ca^{2+} ions. Unlike the *B. licheniformis* amylase that contained no cysteine, the *P. furiosus* enzyme contained five cysteines (C152, C153, C165, C387, and C430), only four of which (C152, C153, C387, and C430) were conserved in the *P. kodakaraensis* α -amylase. Mutant and wild-type α -amylases are strongly destabilized by dithiothreitol and ethylenediaminetetraacetic acid, suggesting that metal binding was involved in the amylase thermostability. Inductively coupled plasma-atomic emission spectrometry showed the presence of Ca^{2+} and Zn^{2+} metal ions in *P. furiosus* α -amylase. Although Ca^{2+} is known to contribute to α -amylase stability, the absence of two out of the three conserved Ca^{2+} ligands in the *P. furiosus* amylase suggested that a different set of amino acids was involved in Ca^{2+} binding. Evidence was provided suggesting that C165 was involved in Zn^{2+} binding and that C165 was essential for the stability of *P. furiosus* α -amylase at very high temperatures. Adjustment of amylase thermal stability with various metal ions is important for tailoring a TTI system to the needs of a food sterilisation process.

P. furiosus is a fast growing microorganism. During cultivation of *P. furiosus* amylase on complex medium (Koch, et al., 1990) the amylase activity reached a maximum of 150 U.l⁻¹ (U

= $\mu\text{mol}\cdot\text{min}^{-1}$) and 2.8×10^9 cells.mL⁻¹ after 13 hours and then decreased. Optimal growth and amylase production (more than 200 U.l⁻¹ after 8 hours and 6.2×10^9 cells.mL⁻¹) was obtained during cultivation of *P. furiosus* on a modified medium containing soluble starch and elemental sulphur, at 98°C, pH 6.6 and under an atmosphere of H₂/CO₂ (80/20). Starch was randomly attacked by the amylase forming a mixture of various oligosaccharides. Eighty percent of the amylase was present in the culture supernatant, which is typically the waste stream from a fermentation. This made it ideal was a candidate source of TTI material. The native enzyme from *P. furiosus* was a homodimer with a molecular mass of 129 kDa. Its deduced amino acid sequence displayed strong homology to the α -amylase of *Dictyoglomus thermophilum*, an obligately anaerobic, extremely thermophilic bacterium.

P. furiosus amylase is active over a broad temperature (40 – 140°C) and pH range (3.5 – 8.0), with the optimum activity at 100°C and pH 5 (Koch et al., 1990). In contrast, Ladermann et al. (1993) found the optimum pH range between 6.5 – 7.5 and Brown et al. (1990) found it to be 5.6. Metal ions were not required for amylase activity, the addition of Co²⁺, Ni²⁺ and Fe²⁺ slightly inhibited the enzyme and addition of 2 mM of Cr³⁺, Zn²⁺ and Cu²⁺ caused almost a complete inhibition. Ca²⁺ ions caused a slight stabilisation of the enzyme.

In terms of the amylase stability to heat, no loss of activity was detected after 6 hours of incubation at 90°C (Koch et al., 1990). At 120°C, about 10% of the initial activity was measured after 6 hours. This equated to a decimal reduction time at 120°C of 6 hours ($D_{120} = 6$ hours). In order to inactivate the enzyme completely, incubation had to be performed at 130°C for at least 1 hour. These levels of heat stability are higher than those required to measure a thermal sterilisation process, where the target is to exceed at least 3 minutes at 121.1°C (F₀ 3) but the process can sometimes be as high as F₀ 50. Adjustment of the amylase thermal stability may be required.

5.1.2 *Pyrococcus woesei*

Pyrococcus woesei is also an anaerobic, hypothermophilic archaeobacterium which has been isolated by Fiala and Stetter (1986) from hot water in Vulcano (Italy). The microorganism has a slightly irregular non-motile coccus-shape and the specific activity of the amylase from *P. woesei* was much higher when compared to the enzymes from moderate thermophilic anaerobic eubacteria.

P. woesei also produces an extremely thermostable and thermoactive amylase. Cultivation on starch with elemental sulphur under continuous gassing (H_2/CO_2 , 80/20) produced $250 U.l^{-1}$ of α -amylase (Koch et al., 1991). On a complex medium without elemental sulphur under 80% N_2 and 20% CO_2 atmosphere, amylase production could be elevated up to $1,000 U.l^{-1}$. Optimal growth and amylase production was obtained during cultivation of *P. woesei* on a modified medium containing soluble starch, but without elemental sulphur, pH 6.5, $98^\circ C$ and under N_2/CO_2 (80/20). The α -amylase consisted of a single sub-unit with a molecular mass of 68 kDa (purified after absorption onto starch and desorption by preparative gel electrophoresis). The amylase was capable of randomly hydrolysing the α -1,4-glycosidic linkages of amylopectin, glycogen and amylose to form various oligosaccharides. The α -amylase also hydrolysed native starch, but unlike other α -amylases, it did not form glucose as an end product.

P. woesei amylase is active over a broad temperature ($40 - 130^\circ C$) and a pH range (3.5 – 8.0), with the optimum activity of the amylase at $100^\circ C$ and pH 5.5 (Laderman et al., 1993). Metal ions are not needed for amylase activity, the addition of 1 - 5 mM Cr^{2+} , Cu^{2+} , Fe^{2+} and Zn^{2+} causes amylase inhibition. Almost 20% of amylase activity was detected even at $130^\circ C$ and for the complete inactivation of the α -amylase at least 8 hours of autoclaving at $120^\circ C$ and pressure of 2 bars was necessary.

The amylase from *P. furiosus* displayed a temperature optimum of activity similar to that observed with the amylase purified from the hyperthermophilic *P. woesei* (Laderman et al., 1993). The amylases differed in that the purification of the protein from *P. woesei* involved the capacity of the amylase to bind substrate at ambient temperatures, while *P. furiosus* amylase only bound to substrates at temperatures required for amylase activation.

Extremely thermostable amylase from *P. furiosus* was of great interest as material for a candidate sterilisation TTI. Heating at $120-130^\circ C$ for lengths of time indicated that sufficient amylase activity remained to allow detection in an assay. In its 'pure' form as extracellular material, *P. furiosus* amylase appeared to show a level of heat stability greater than that required for a food sterilisation treatment. This was ideal as a starting position because it is easier to reduce heat stability through metal ion adjustment than to increase it. A programme

of work was initiated to obtain and study *P. furiosus* amylase with the objectives of using it as a sterilisation TTI.

5.1.3 Methods for the measurement of amylase activity

There are several methods that can be used for measuring amylase activity. Conventional assays, such as those described in Chapters 2 and 3, operate at temperatures in the range 25-30°C, where most amylases are near their optimal temperature. Amylases from hyperthermophilic microorganisms, however, are optimally active at much higher temperatures. Conventional assay techniques cannot be used and so alternative methods are required.

Koch et al., (1990) used the method of Bergmeyer and Grassl (1983) to determine the amylase activity. According to this method, 100 µL of amylase solution was added to 250 µL of sodium acetate buffer containing 1% starch. Acid hydrolysis of the starch gave products (amylose, pullulan and maltose) identified by employing HPLC using a Carbohydrate HPX42A column operating at 85°C. Eluted sugars were monitored by a differential refractometer to determine the rate of concentration increase of these sugars.

Laderman et al. (1993) determined the activity of amylase using a modification of the assay of Manning and Campbell (1961). A 20 µL sample containing the amylase, 1% soluble starch and 100 mM sodium phosphate was incubated at pH 7.0 and at 92°C for 10 minutes. Colour was developed by the addition of 15 µL of an iodine solution (4% KI, 1.25% iodine) and an additional 1 mL of distilled water was added to each sample to dilute the colour of the sample to a measurable range at 600 nm. One unit of the amylase activity was defined as the amount which hydrolysed 1 mg of starch.min⁻¹. This is similar to the traditional starch-iodine test.

Brown et al. (1990) determined the activity of amylase by measuring the amount of reducing sugars released during incubation with starch. A 0.5 mL volume of 2% soluble starch was added to 0.5 mL of 0.1 M sodium acetate-acetic acid buffer (pH 5.6). A portion (10 to 100 µL) of amylase solution was added, incubated for 30 minutes at 98°C. The amount of reducing sugars released was determined by using the dinitrosalicylic acid method (Bernfeld, 1955). In this method, sucrose was hydrolysed and the amount of glucose and fructose was measured through the absorbance between the acid treated sample and the untreated sample.

One unit of amylase activity was defined as the amount of amylase that released 1 mmol of reducing sugar (as glucose standard) per minute under the assay conditions.

5.1.4 Objectives

The primary objective of the work reported here was to determine if amylase from *Pyrococcus furiosus* was suitable for use as a sterilisation TTI. In order for this to be possible, the kinetics of the amylase destruction by heat were limited by the following two constraints:

- (a) It must show sufficient heat stability for some of the active amylase structure to remain after several minutes heating at 121.1°C. The commercial requirement is for sterilisation processes to achieve at least an equivalent process of 3 minutes at 121.1°C. However, this is often increased to allow for product and process variability, and to target spoilage microorganisms of higher heat resistance (Stumbo, 1965). This is discussed briefly in Chapter 1. Decimal reduction time (D_T -value) for the amylase at 121.1°C was the parameter that characterised the heat stability.
- (b) It must exhibit a temperature sensitivity of breakdown that is characterised by a z-value close to 10°C. This is the value used to represent the destruction of *Clostridium botulinum* spores (Stumbo, 1965).

Finding a TTI material with thermal behaviour within these constraints is extremely difficult, otherwise a liquid sterilisation TTI would already have been discovered and available for use.

Several stages were involved in achieving these objectives; these are described in detail in subsequent sections of this report:

- The first was to determine whether the *Pyrococcus furiosus* microorganism could be grown in conditions that were favourable to amylase production and in the quantities suitable for use as a TTI. This proved more difficult than expected because of the extreme nature of the fermentation conditions and doubts over the viability of the microorganisms supplied.

- Purification of the amylase was the next issue since it is reported that up to eighty other enzymes are produced in the fermentation, as well as numerous by-products of the fermentation that may affect the amylase performance (Adams et al., 2001). This thesis work focussed on finding a suitable candidate material for the sterilisation TTI, and conducting sufficient tests to confirm that the D- and z-values were in the correct range.
- Encapsulation of the sterilisation TTI was achieved using the same method as with the pasteurisation TTIs; that was within silicone tubes capped with a silicone elastomer compound. These TTI tubes gave the greatest flexibility for applications to industrial processes. Integrity of these TTI tubes at sterilisation process conditions was unknown, i.e. temperatures of 115 to 135°C, pressures up to 4 bar, and very rapid pressure changes.
- There was also the need to determine which assay method was appropriate to an amylase with optimal activity close to 100°C.

5.2 Production of *Pyrococcus furiosus* amylase

Certain definitions are important at this stage. Chapter 1 describes the nomenclature for different TTI systems. The new thermostable amylase from *Pyrococcus furiosus* should be referred to as PFA121. For much of this report, however, the PFA121 TTI was in the form of freeze-dried-powder (FDP) from the *Pyrococcus furiosus* fermentation, and is referred to as FDP. When the FDP was dissolved in buffer solution and encapsulated within a silicone TTI tube it was referred to as a sterilisation TTI.

Obtaining a consistent supply of amylase from a hyperthermophilic microorganism such as *Pyrococcus furiosus* proved to be a difficult task. Attempts to culture the microorganism at University of Birmingham failed on several occasions while the work in this thesis was ongoing. It was thought that one of the reasons was in the viability of the starting culture. A “live” culture under oil or broth might have made this more successful rather than the lyophilised cultures supplied from the culture collection. The process of lyophilisation exposes the anaerobes to low temperatures and probably did not ensure a total absence of oxygen until the vacuum was formed, both of which are detrimental to culture viability. After

several failures in the fermentations at Birmingham, it was decided to out-source this task to a institution with a track record in growing *Pyrococcus furiosus*.

A group at the Health Protection Agency (HPA) in Porton Down was active in continuous fermentation of *Pyrococcus furiosus*, and agreed to supply a 1-litre sample of unwanted fermentation broth. Results from this showed extremely high levels of amylase activity but there was insufficient sample to continue with the tests. A summary of the results from the first tests on this amylase are given below. Note that details on the assay method form a study in itself later in section 5.3.

Summary of the first *Pyrococcus furiosus* amylase results:

- *Pyrococcus furiosus* ACDP1 culture supernatant, pH 7.0 from HPA, Porton Down
- Heated in glass capillary tubes for 0, 10 and 20 minutes at 121°C.
- Assay conditions:
20 µL 1% starch, 20 uL 100mM phosphate buffer, pH 7.0 (conditions of Koch et al., 1990). Incubate for defined time at 92°C. Stop reaction by cooling on ice; add 15 uL iodine, add 1 mL water. Measure absorbance at 600 nm.
- Results:
Activity still present after heating at 121°C, but more thermostable than required.

Heating time at 121°C (minutes)	Rate (minutes⁻¹)
0	0.056
10	0.045
20	0.044

These were the first heating tests at sterilisation temperatures and used the fermentation broth directly in glass capillaries with no concentration. This was source of highly active amylase. The tests showed that there was residual amylase activity after 20 minutes at 121°C, and it looked very promising for further experiments to refine the broth. Unfortunately the HPA

group was closed down for commercial reasons and the source of high temperature amylase was lost.

Further groups with active interests in *Pyrococcus furiosus* fermentation were sought through web searches and publication databases. Universities of Maryland and Georgia were identified. A sample of fermentation broth from University of Maryland was supplied but showed minimal amylase activity (see Table 5.1). After this, a collaboration with the University of Georgia (Department of Biochemistry & Molecular Biology) was set up because of their track record with *Pyrococcus furiosus* fermentation and enthusiasm to work together (Adams et al., 2001).

5.2.1 *Pyrococcus furiosus* growth medium

Pyrococcus furiosus was grown by University of Georgia on a rich medium containing yeast extract, according to published methods (Verhagen et al., 2001; Adams et al., 2001; Schut et al., 2003). Peptides, maltose or starch provided the primary carbon sources (see item f in Appendix 1 which contains details of the preparation methods used by University of Georgia).

Fermentation broths were supplied from three 1-litre cultures of *P. furiosus*, so that they could be compared for amylase activity and relative heat stability. Each broth used a different source of carbon; peptides, maltose or starch. The peptides/S medium contained 0.5% (wt/vol) casein hydrolysate (enzymatic), while the maltose (1%, w/v) and starch (1%, wt/vol) media contained the indicated carbohydrates. All the proteins, including thermostable amylase, were precipitated out from the supernatant using ammonium sulphate.

On receipt of the precipitate at CCFRA, the ammonium sulphate pellets were resuspended in an equivalent volume of 50 mM ammonium bicarbonate buffer, pH 7.0. This was dialysed against the same buffer to remove residual ammonium sulphate. The dialysate was freeze-dried and the resulting freeze-dried-powder (FDP) used to prepare solutions for amylase assay. Figure 5.1 shows the FDP from one of the three cultures as a low density white powder.

Table 5.1: Details of various *Pyrococcus furiosus* fermentation broths supplied as material for an amylase based sterilisation TTI.

Source	Vol of broth (L)	Amt of FDP (g)	Protein content (μg protein/mg FDP)	Amylase activity $\Delta_{600}/\text{min}/20\mu\text{L}$ of mg protein/mL buffer
Porton Down <i>P. furiosus</i> ACDP1	0.5	1.8	23	2.2 10 mM phosphate buffer, pH 7.0
University of Maryland <i>P. furiosus</i>	10	0.24	0.8	trace 10 mM acetate buffer, pH 5.0, 1 mM CaCl_2
The University of Georgia <i>P. furiosus</i> <i>Starch carbon source</i>	1	0.431	13.2	trace 10 mM acetate buffer, pH 5.0, 1 mM CaCl_2
The University of Georgia <i>P. furiosus</i> <i>Maltose carbon source</i>	1	0.010	0.0	-
The University of Georgia <i>P. furiosus</i> <i>Peptides carbon source</i>	1	0.190	43.5	0.62 10 mM acetate buffer, pH 5.0, 1 mM CaCl_2



Figure 5.1: FDP from one of the three cultures as a low density white powder.

FDP from the U. Georgia fermentation using starch as the carbon source did not contain sufficient amylase activity for use as a TTI. It is likely that additional enzymes were produced by *P. furiosus* during metabolism on starch and these broke down any amylase. Also, the maltose source of carbon resulted in a low FDP weight and it was not possible to measure amylase activity. However, amylase activity was measured at high levels from the fermentation broth using peptides as the carbon source. A measurement of 0.62 in 20 μL of 25 mg FDP/mL acetate buffer was made. This was a level that could be used in a dissolved form for TTI work.

5.2.2 Encapsulation of freeze-dried-powder into TTI tubes

One major advantage of a liquid sterilisation TTI compared with one in powder form is the option of encapsulation within silicone TTI tubes. Chapter 2 describes in detail how these tubes are made. FDP from the fermentation using peptides as a carbon source was dissolved at 25 mg FDP/mL of 10mM acetate buffer (pH 5.0 and containing 1 mM CaCl₂). Between 25 and 30 µL of the FDP solution was injected into each TTI tube. Once the FDP solution was encapsulated in the TTI tubes it was ready for use.

Filled TTI tubes were stored frozen in acetate buffer until ready for use, which included the time during transportation to and from the industrial processing plants. Frozen storage had been shown to maintain high amylase activity for many months (see Chapter 3) if the TTI system used an amylase buffer. This is important for ensuring the TTI method has practical application to thermal processing operations where factories are located some distance from CCFRA. The two trials at Masterfoods and Baxters, reported later in this chapter, challenged this in that one factory was located in East Anglia and the other in the Scottish Highlands. First class post was used successfully to transport the frozen TTIs between CCFRA and the factories with ice blocks remaining partially frozen on receipt of the TTI tubes.

Only 0.19 g of FDP was obtained from the 1-litre fermentation using peptides as the carbon source. This meant that only a limited number of TTI tube trials to evaluate the effectiveness of the FDP as a sterilisation TTI were possible, and thus careful planning was needed. A proportion of this material was used in practising how to carry out the various experiments, for example in developing the new assay procedure, before the FDP could be used for thermal tests.

Each TTI tube or glass capillary tube contained approximately 25 µL of FDP solution, at a concentration of 25 mg/mL buffer, which was 0.000625 g per TTI tube. Therefore, the total number of TTI tubes available from 0.19 g of FDP was 304; this assumed no wastage. Such a low number focussed the experimental plan in order to obtain the maximum quantity of valuable data from the 0.19 g of FDP.

5.3 Development of the discontinuous assay methods

Conventional amylase assays used with the amylase TTI systems for pasteurisation had previously been conducted using reagent purchased from Sigma or Randox (Tucker et al., 2005). Chapter 1 describes these methods. They have the benefit of being continuous assays that are carried out using a laboratory spectrophotometer or a portable colorimeter. The ideal situation would be for this type of continuous assay to be appropriate to the sterilisation TTI.

5.3.1 Randox assay

Conventional Randox assays described in Chapter 1 are conducted at 30°C because this temperature is optimal for amylases originating from mesophilic microorganisms. However, amylase from *Pyrococcus furiosus* has minimal activity at 30°C (Koch et al., 1990) and so these standard amylase assays were unlikely to work. It was necessary to first determine a method by which the amylase activity for the *P. furiosus* FDP could be measured. Despite small quantities of FDP, a proportion of this was used in the development of an assay method. Most work on assay development used 15 mg FDP per mL of buffer solution. This concentration was chosen because the active amylase component of the FDP (see Table 5.1) was in a similar range to that for the *B. amyloliquefaciens* and *B. licheniformis* amylases (see Chapter 1).

A FDP solution was made by adding 20 µL of FDP (15 mg resuspended per mL of 10 mM acetate buffer, pH 5.0 containing 1 mM calcium chloride) to 1 mL of Randox amylase reagent at 90°C (Randox Laboratories, Catalogue number AY1580). A Randox assay was the ideal system because it provided a continuous assay that took a few minutes for the measurement to take place. Rate of increase of absorbance at 405 nm was measured with a spectrophotometer. Unfortunately, at 90°C the amylase substrate precipitated from solution, and so this assay was unsuitable for activity measurement with this thermostable amylase. Limited success was obtained at temperatures of 40-50°C because of the lengthy incubation times required for the amylase to become active. Another approach was required for the assay, and so a discontinuous starch-iodine method was investigated.

5.3.2 Starch assay

The starch/iodine assay was chosen for the *P. furiosus* amylase because of the need to operate at temperatures close to 100°C. Despite the disadvantages of a discontinuous assay there are advantages of the starch/iodine approach. One is the less expensive materials, another is that it might be possible to dispense with an instrumental colour measurement and use colour charts to determine colour readings.

Amylase activity was measured by incubating, at 92°C and pH 5.0, a mixture of 20 µL of 1% soluble starch, 20 µL of 100 mM acetate buffer and 20 µL FDP (15 mg resuspended per mL of 10 mM acetate buffer, pH 5.0 containing 1 mM calcium chloride). Incubation was for a range of time intervals up to 15 minutes so the reaction with starch could progress towards completion. The reaction was stopped by the addition of 1 mL of ice cold water and the colour developed by addition of 15 µL of iodine solution (4% potassium iodide and 1.25% iodine solution). Figure 5.2 shows the range of colour changes from black to yellow as the amylase acts on the starch solution. Each of these tubes were incubated at 92°C for 15 minutes, and in doing so reached the end point of the amylase-starch reaction. Zero amylase activity is shown as a black colour whereas high activity shows as a yellow colour. Absorbance was read at 600 nm and plotted against incubation time. Activity (ΔA_{600} nm/minute/20 µL sample) was calculated from the gradient.



Figure 5.2: Gradation of colour with discontinuous starch/iodine assay. Tube #1 shows a sample with high amylase activity and tube #4 with no activity. Tubes were incubated at 92°C for 15 minutes.

5.3.3 Calculation of amylase activity rates

Traditional amylase activities are calculated from the gradient of absorbance against time, using a continuous assay that measures colour change. Chapter 1 describes this method and presents Figure 1.5 as an example of absorbance data for a *Bacillus amyloliquefaciens* amylase, with the data points measured with a colorimeter. Activity for this example was taken as the maximum gradient, which in the example given, was between time reading of 20 and 50 seconds.

The difference between the continuous colorimeter measurements using 25 μL of solution from a single TTI tube and the discontinuous starch-iodine method is that each of the points in Figure 1.5 corresponds to absorbance measurements from one sterilisation TTI tube containing 25 μL of FDP solution. Therefore, to obtain the same number of data points as in Figure 1.5 it is necessary to use thirteen aliquots of the sterilisation TTI, or 13 x 25 μL of FDP solution. Each tube is incubated at 92°C for a fixed time before the colour measurement is taken. Thus, the sterilisation TTI assays require more time to carry out and the sample volume to achieve the same end result of an activity rate is considerably higher. This encouraged further work to optimise the FDP concentration in buffer solution.

The following section describes some of the D-value measurements that were made with the FDP in acetate buffer. Development of the assay procedure was undertaken simultaneously with measurement of D-values otherwise the 0.19 g of FDP would not have been sufficient to gather the data that proved this novel TTI approach worked.

5.4 Determination of D- and z-values for the FDP using isothermal measurements

Isothermal methods for D- and z-value measurement are the industry standards because of their relative simplicity (see Chapters 1 and 2). Thus, immersion of sealed glass capillary tubes in an oil bath at 121°C was used to obtain the first data on the D_{121} -value for the sterilisation TTI. The downside of this approach was that isothermal D-value experiments required high quantities of FDP because of the demands of the discontinuous assay (described above). Therefore, much of the thermal characterisation used non-isothermal methods because

they were more effective in their use of the 0.19 g of FDP. All z-value work was from non-isothermal kinetics in order to avoid having to repeat D-value measurements at different temperatures. This would have used most, if not all, of the FDP sample and would not have enabled any industrial testing to be carried out.

It was considered an essential step to first measure the D-value at 121°C to confirm whether the FDP was of suitable heat stability. This required isothermal experiments to be conducted at 121°C using the FDP solution enclosed within glass capillary tubes immersed in a well stirred oil bath. The discontinuous assay required a minimum of five capillary tubes to calculate a single reaction rate for each immersion time at 121°C. Thus, five tubes were removed from the oil bath together at 0, 5, 11 and 15 minutes, and immersed in cold water to quench the amylase degradation. The four immersion times of 0, 5, 11 and 15 minutes required a total of 20 capillary tubes in addition to those for zero heating time. Figure 5.3 shows these data.

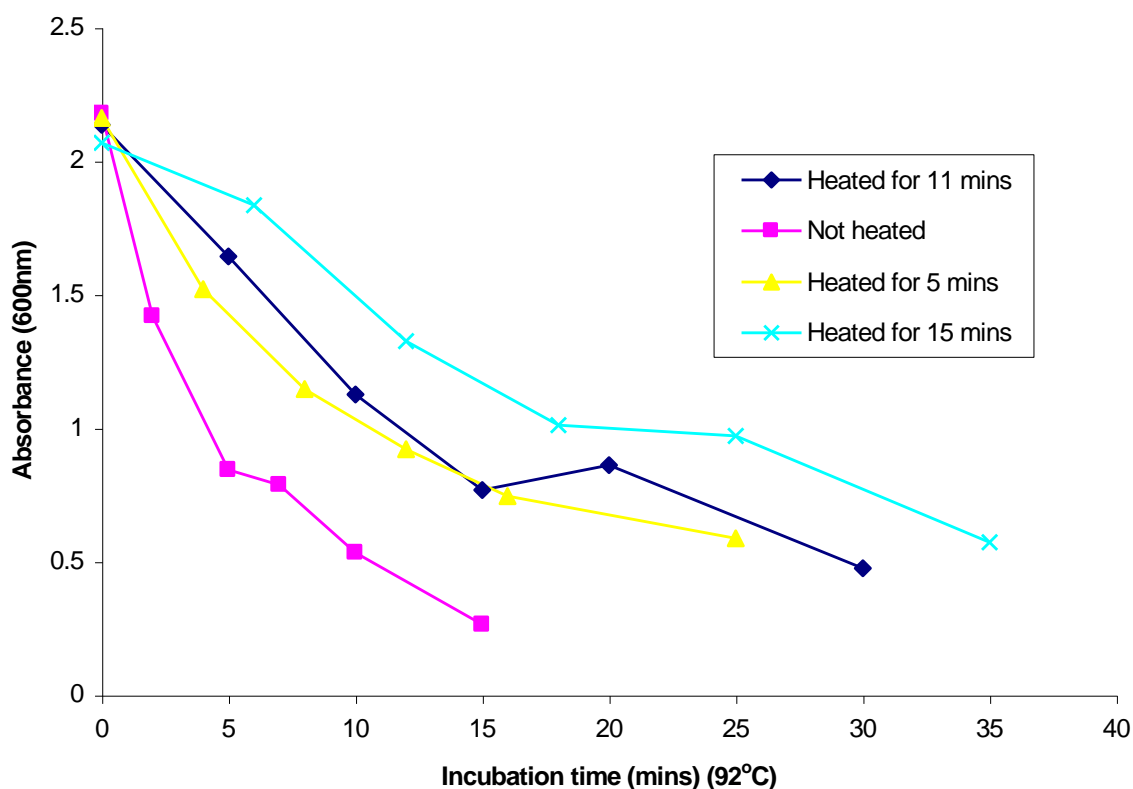

Figure 5.3: Discontinuous assay data for four different heating times at 121°C; 0, 5, 11 and 15 minutes. Five glass capillary tubes were incubated at 92°C from each heating time at 121°C. FDP concentration was 15 mg/mL of acetate buffer.

Amylase activity is estimated from the maximum gradients from these reaction curves. Typically the curves display a lag before the reaction starts, followed by a period of maximum activity in which the amylase is reacting with the substrate, and finally the rate slows as the reacting species are used up. With discontinuous assays, the position of maximum gradient is not always clear because each point is a measurement from a different glass capillary sample. For these discontinuous assays, two time periods were chosen over which the gradients were calculated. These were for each heating time at 121°C between 0 and 2 minutes incubation and between 0 and 5 minutes incubation, as given in Tables 5.2 and 5.3 respectively. This only affected the value for zero heating time at 121°C.

Table 5.2: Amylase activities calculated from the gradients between 0 and 2 minutes incubation at 92°C, from Figure 5.3.

Heating time at 121°C (minutes)	Activity, N (minute⁻¹)	N/N₀	log N/N₀
0	0.375	1.000	0.000
5	0.160	0.422	-0.374
11	0.092	0.243	-0.614
15	0.061	0.162	-0.792

Table 5.3: Amylase activities calculated from the gradients between 0 and 5 minutes incubation at 92°C, from Figure 5.3

Heating tme at 121°C (minutes)	Activity, N (minute⁻¹)	N/N₀	log N/N₀
0	0.261	1.000	0.000
5	0.160	0.613	-0.213
11	0.092	0.352	-0.453
15	0.061	0.234	-0.631

These data are illustrated graphically in Figures 5.4 and 5.5 using the traditional approach of plotting the logarithm of ratio of final activity (N) divided by initial activity (N_0) as a function of heating time (Stumbo, 1965). Figures 5.4 and 5.5 represent data from the same experiment conducted using FDP at a concentration of 15 mg/mL buffer.

D-values at 121°C of 18.1 and 23.9 minutes were encouraging, since they were in a range that represented F_0 -values for sterilised foods. (Ball and Olson, 1957). The important aspect of this was that *P. furiosus* amylase as a candidate material for producing a sterilisation TTI in solution appeared to provide suitable heat stability. Thermal processes with commercial F_0 -values between 6 and 20 minutes could be measured using this TTI.

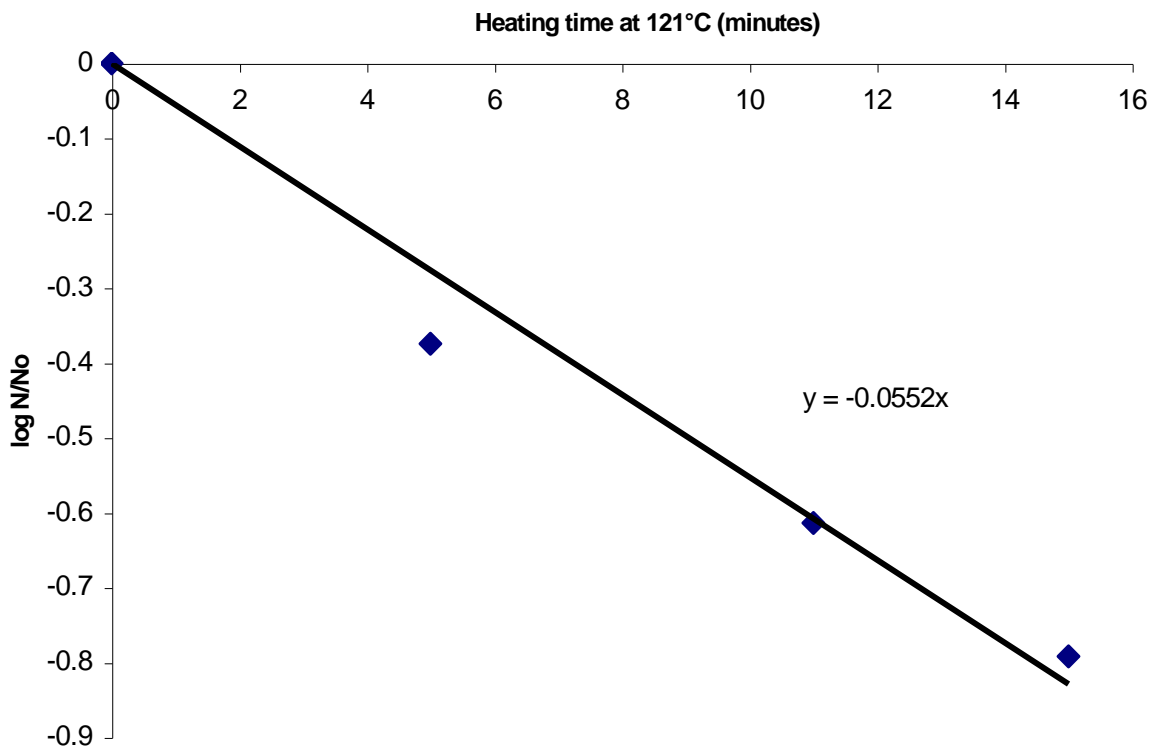

Figure 5.4: Graph of heating time at 121°C against log of final activity (N) divided by initial activity (N_0). Gradients for each point taken between 0 and 2 minutes incubation at 92°C. D-value was 18.1 minutes at 121°C.

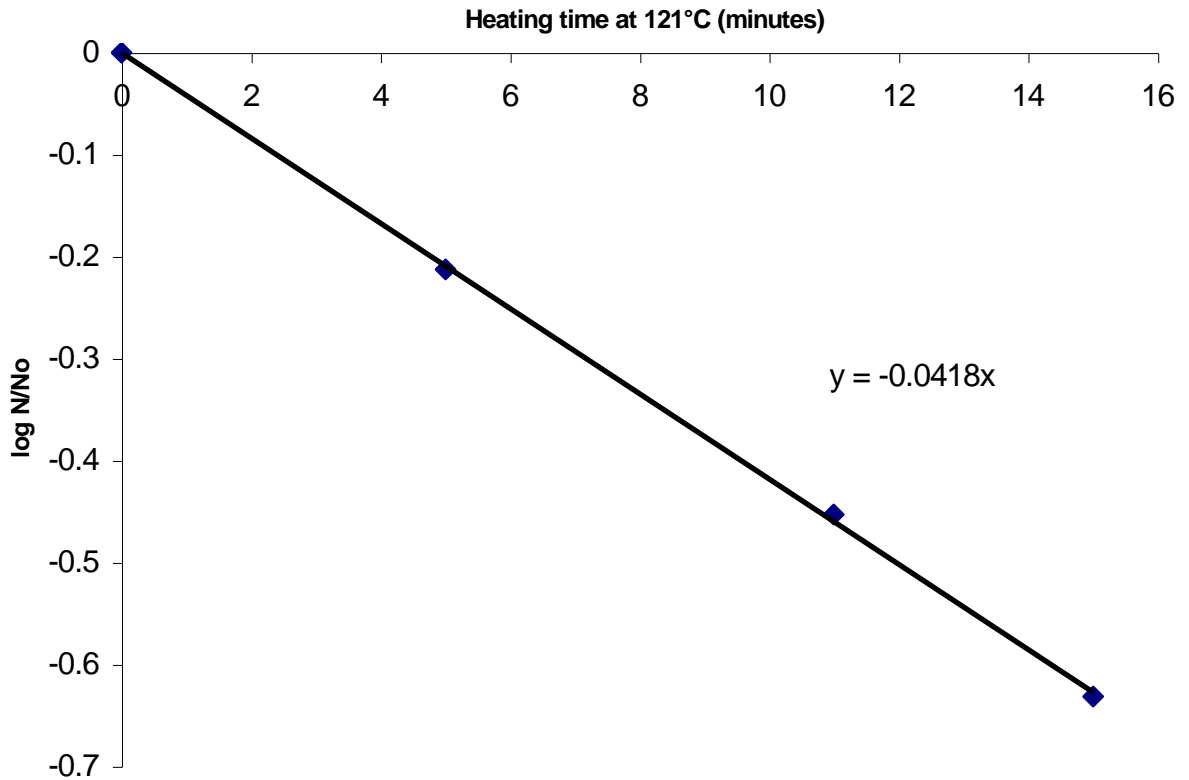

Figure 5.5: Graph of heating time at 121°C against log of final activity (N) divided by initial activity (N₀). Gradients for each point taken between 0 and 5 minutes incubation at 92°C. D-value was 23.9 minutes at 121°C.

5.4.1 Optimising the isothermal D-value methods to conserve FDP

One limitation of using the FDP at 15 mg/mL buffer was the amount required to complete one measurement of either a D-value or of a series of activity rates for calculating a sterilisation value; as only 0.19 g of FDP was available. An alternative method was investigated in which a higher concentration of FDP was used, and the TTI solution was diluted before the assay was conducted. This allowed four replicates to be produced from the one sample and so four points could be obtained for calculating the gradient.

Another series of heating tests at 121°C were carried out using glass capillary tubes in a well stirred oil bath. FDP at 25 mg/mL acetate buffer was heated in the glass capillaries and diluted after heating to 5 mg/mL for the incubation tests at 92°C. This enabled five incubation times

to be used for obtaining the gradient at each heating time at 121°C. Gradients were calculated between 0 and 5 minutes at 92°C, based on the findings from work reported in Tables 5.2 and 5.3. Figure 5.6 shows the plot of logarithm of activity ratio (final activity divided by initial activity) as a function of heating time at 121°C. Each of the points in Figure 5.6 was determined with an effective FDP concentration of 5 mg/mL buffer, which was considerably less than with the data presented in Figures 5.4 and 5.5.

Of interest with this trial was whether the reduced FDP concentration was sufficient to measure amylase activities with sufficient accuracy. It was known from trials with the pasteurisation TTIs that amylase activity decreased during storage time. Chapter 3 contains detailed descriptions of work with the BAA70 TTI, which is also a TTI in an acetate buffer. A dilution from 25 to 5 mg/mL might cause greater inconsistency with the assays at high heating times because there is less active amylase as a starting material.

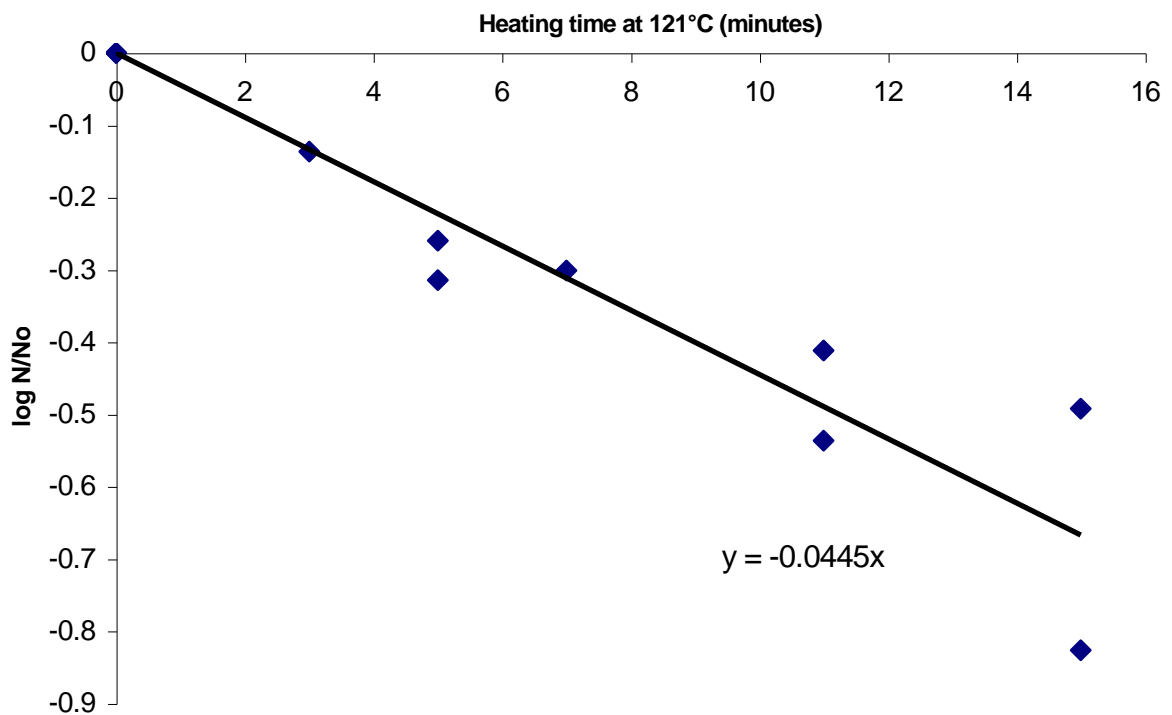

Figure 5.6: Graph of heating time at 121°C against log of final activity (N) divided by initial activity (N₀). Gradients for each point taken between 0 and 5 minutes incubation at 92°C. D-value of 22.5 minutes at 121 °C for 5 mg FDP / mL acetate buffer.

The D_{121} -value was calculated from the regression line as 22.5 minutes, which was between the two values from Figures 5.4 and 5.5, which used FDP at 15 mg/mL buffer. This suggested that the heat stability of the FDP in acetate buffer was insensitive to FDP concentration within the range 5 to 25 mg/mL buffer. Figure 5.6 presents the data from Figures 5.4 to 5.6 on one graph to illustrate the similarity and to validate either approach.

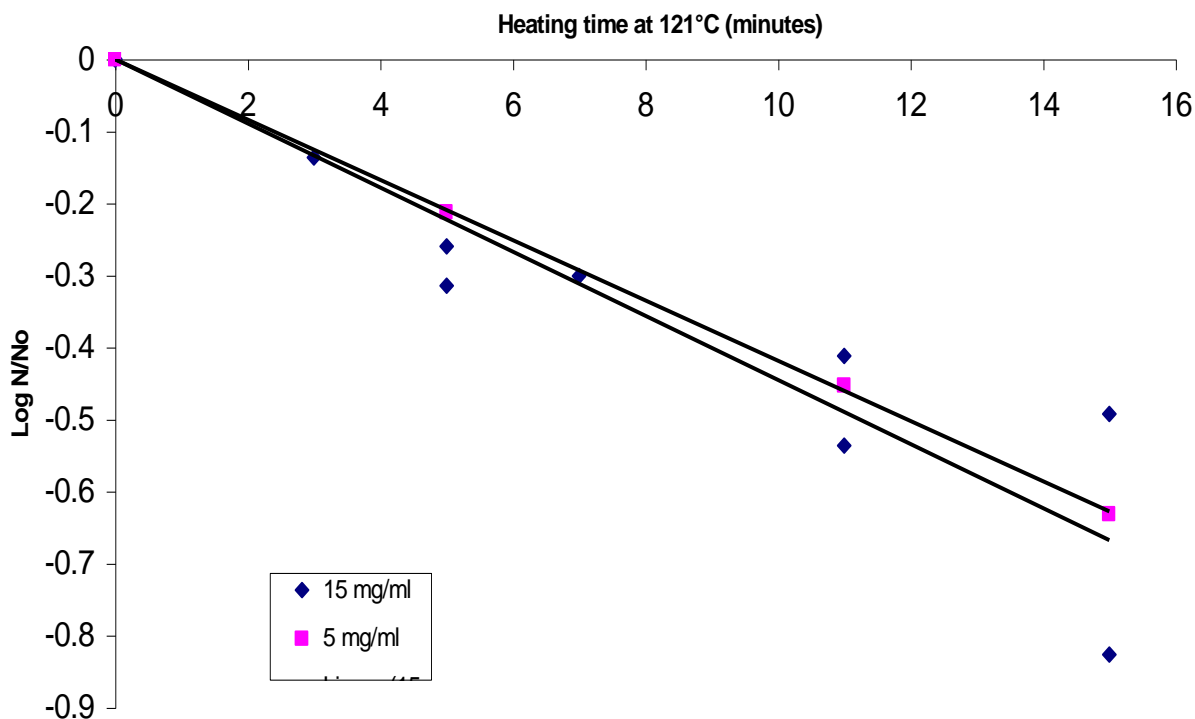

Figure 5.7: Graph of heating time at 121°C against log of final activity (N) divided by initial activity (N_0) for FDP at 15 mg/mL and diluted from 25 to 5 mg/mL.

The method developed for conducting assays with this TTI system is to start with a solution of 25 mg/mL FDP concentration and to dilute this after the heating test is completed. This is more economical with the FDP and requires only one TTI tube to be heated in order to obtain an activity value. When transferring this technology to industry, it would be unrealistic to use five different TTI tubes to obtain one activity value (N), and hence calculate a single F-value from Equation 5.1.

$$F = D_r \cdot \log\left(\frac{N_0}{N}\right) \quad 5.1$$

Accuracy with the data presented in Figure 5.7 suggests that there is little difference between the D-values from either 15 mg/mL FDP concentration or if it is diluted from 25 to 5 mg/mL after the heating test is completed. However, it is noticeable with the diluted FDP that the differences between duplicate readings (from the same glass capillary) diverge as heating time increases. This is likely to be caused by very low amylase activities remaining in solution and so the accuracy of this test at heating times greater than 10-15 minutes is reduced. This will have implications when this TTI system is used for industrial tests in which a degree of over-processing is usually built into the thermal processing conditions. Typical industrial process values (F_0 -values) tend to range from 4 to 20 minutes at 121.1°C. F_0 -values over 10 minutes are likely to be less accurate.

5.5 Non-isothermal calibration

Data on the D-value at 121°C gave confidence that FDP from *P. furiosus* fermentation broth, when grown in a peptide rich medium, was a candidate as a sterilisation TTI. Approximately half of the 0.19 g of FDP had been used in the work on developing methods for assaying amylase activity and in obtaining isothermal D-values. It was clear that measurements of z-value, which required at least four D-values to be measured, could not be done without exhausting the rest of the FDP. This would leave no scope for testing this TTI material in any industrial conditions. An alternative to traditional isothermal kinetic methods was thus evaluated at this stage.

There are two main limitations of the traditional isothermal kinetic method for measuring D- and z-value:

- The experiments need to be repeated at several different temperatures, usually at least four, in order to calculate the z-value, which is time-consuming and uses precious material.

- Isothermal death kinetics do not represent the nature of heating experienced by a food product, in which the particle or pack temperatures increase gradually during heating before decreasing gradually during cooling.

Non-isothermal methods for kinetic data determination have been used by various research groups (De Cordt et al., 1992; Miles and Swartzel, 1995; Van Loey et al., 1997a). The method requires the sterilisation value or F-value to be calculated simultaneously (as shown in Equation 1.11 as a P-value and Equation 5.2 as an F-value) using amylase activity measured with a TTI and from temperature measurements. This will result in two F-value measurements that will equate providing that the D-value and z-value used in either side of Equation 5.2 are correct for the TTI system.

$$F = \int_0^t 10^{\frac{T(t)-T_{ref}}{z}} \cdot dt = D_{T_{ref}} \cdot \log\left(\frac{N_0}{N}\right) \quad 5.2$$

In Equation 5.2, N is the final amylase activity after a specific time-temperature history, and N_0 is the initial activity. $D_{T_{ref}}$ is the decimal reduction time at the reference temperature (T_{ref}) appropriate to destruction of thermostable amylase, and in this case it was taken at 121°C. $T(t)$ is the measured product temperature, which is a function of time (t). z is the kinetic factor for the FDP, which is the temperature change required to effect a ten-fold change in the $D_{T_{ref}}$ value (°C).

From Equation 5.2, the integration of temperature over time (left side of the equation) will result in the same F-value as that calculated from the sterilisation TTI activities (right side of the equation), provided that first order kinetics have been followed for the amylase destruction throughout the heat process. Hence, by applying the correct z-value to the temperature measurements and the correct D-value for the amylase activities, both sides of Equation 5.2 will be equal. The theory behind non-isothermal kinetics is that a series of experiments are carried out over varying time-temperature conditions with TTIs located at or close by the temperature sensors so that both systems measure the same process. A non-isothermal measurement with a number of matching pairs of TTIs and probes should result in a correlation between pairs of calculated F-values.

It is important to measure a range of F-values calculated using a number of different thermal processes, to represent conditions expected in a food thermal treatment. All F-values must be measured at the end of cooling because this represents the measurement obtained from a TTI system when used for measuring processes in packs of food or in a continuous heat process (Tucker et al., 2002).

One unique pair of D_{121} and z-values is appropriate for all sets of time-temperature data. To achieve a range of F-values, the thermal processing data sets utilised different product heating rates as well as different process temperatures between 121 and 131°C. These sets of time and temperature data provided a range of conditions at which the lethal rates accumulated. Two sets of experimental trials were set up to provide a wide range of F-values to challenge the measurement range of the TTI and thus estimate D_T and z. Figures 5.8 and 5.10 present the time-temperature profiles measured in packs of food processed in two industrial situations.

Trial 1: The first processing style used a commercial Lagarde steam-air retort at Masterfoods, Kings Lynn. Products were packaged in plastic pouches and glass jars. The thermal processes were given depending on the product requirements to achieve commercial values for sterilisation. Different heating rates from the two products and between replicates allowed the time-temperature data to differ in the rates of lethal rate or F-value accumulation. Figure 5.8 shows the time-temperature data that illustrates the increase in F-value from the five sets of data. The pouch product was a pasta cook-in-sauce and the glass jar product a white sauce.

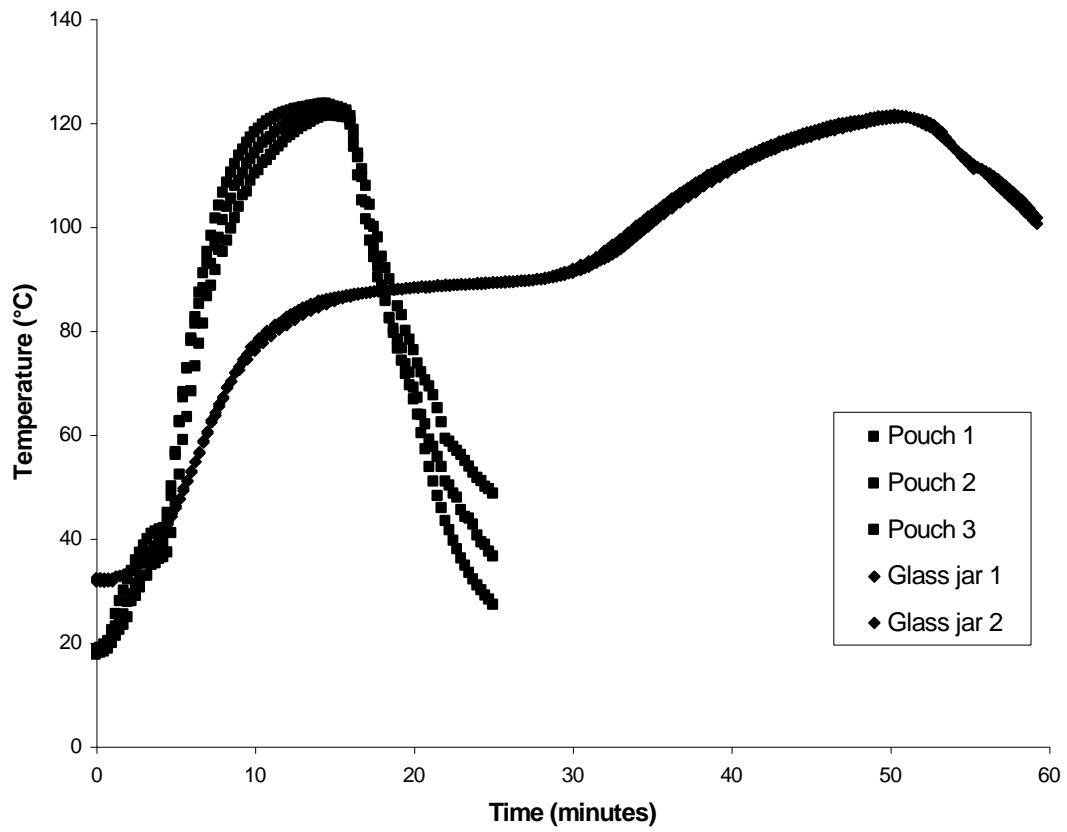

Figures 5.8: Temperature data measured in pouches and glass jars of food processed in a Lagarde steam-air retort.

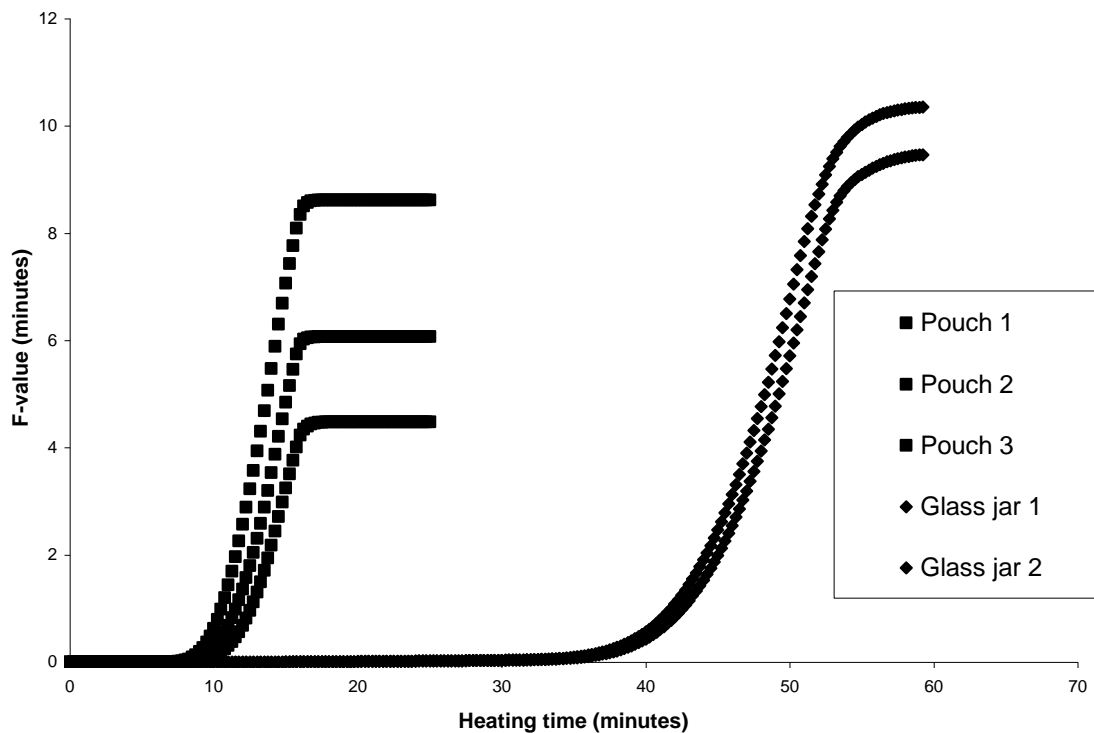

Figures 5.9: F-value data measured in pouches and glass jars of food processed in a Lagarde steam-air retort.

Trial 2: The second processing style used a laboratory simulator of an FMC reel and spiral cooker-cooler with cylindrical metal cans at Baxters, Scotland. In this system, fast axial rotation (FAR) occurred during parts of the process where the cans lost their contact with the reel. The FMC 610B bar simulator (FMC FoodTech, Belgium) achieved this using FAR for one-third of the time it took a can to travel around the reel. This resulted in extremely efficient heat transfer. Water (0), 1 and 2% w/w starch solutions were used to produce three different heating rates for the product. Two different process temperatures were used, 124 and 131°C.

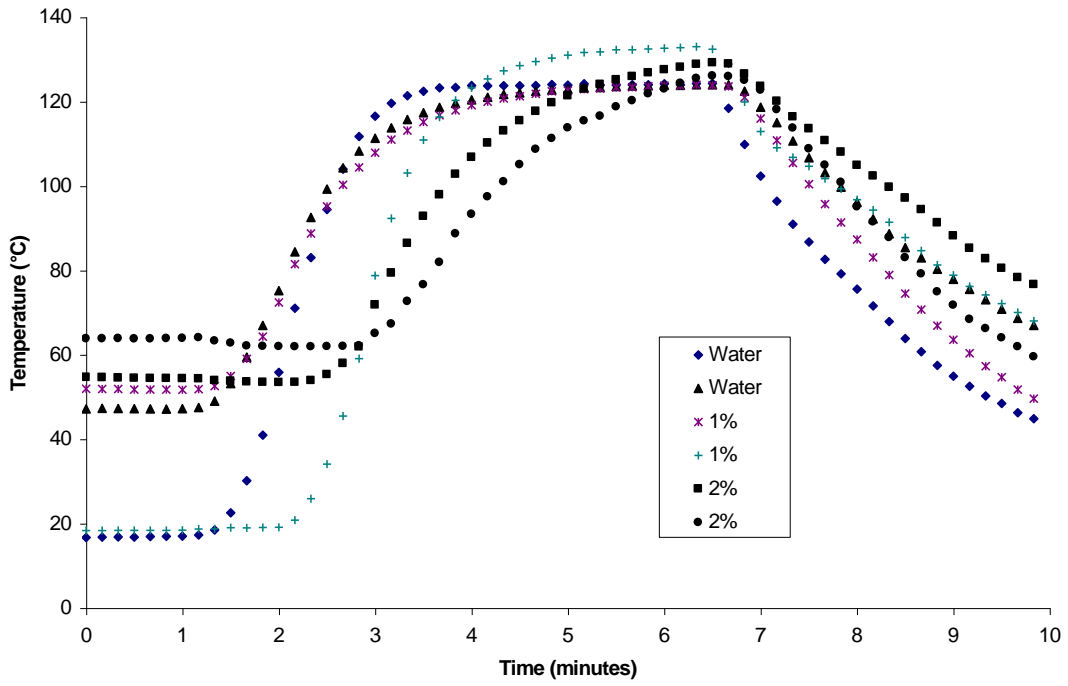
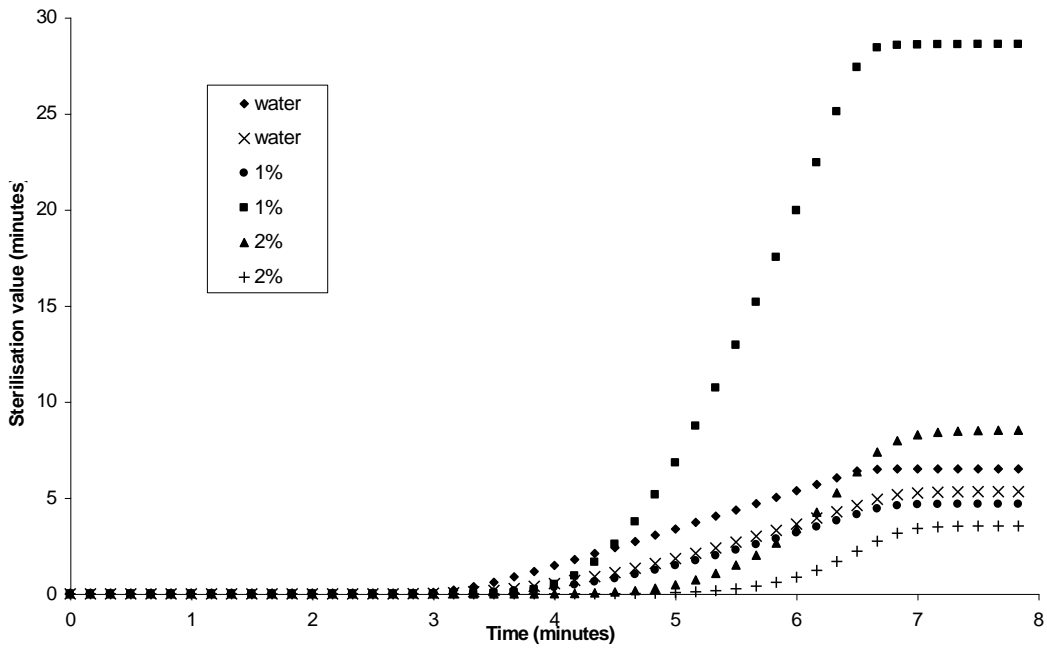

Figure 5.10: Temperature data measured in cans of 0, 1 and 2% starch processed in a FMC 610B simulator.



Figures 5.11: F-value data measured in cans of 0, 1 and 2% starch processed in a FMC 610B simulator.

The objectives of these industrial trials were two-fold:

- To obtain data for use in a non-isothermal measurement of D- and z-value for the FDP in acetate buffer. Several very different time-temperature and time-F-value measurements were experimentally set up so that D- and z-values were appropriate over a wide range.
- The industrial trials were also to evaluate whether the sterilisation TTI tubes would withstand the rigours of a full thermal treatment where pressure swings of up to ± 2 bar can occur almost instantaneously (Pape, 2007).

Temperature and TTI measurements needed to be from the same position within the food product. This was achieved by taping at least one sterilisation TTI tube to the measuring junction of a temperature sensor within the products (see Figure 5.12 from trial 1 and Figure 5.13 from trial 2). Datatrace loggers (Wessex Power Technology Ltd, Poole) and conventional Ellab thermocouple wires (Ellab UK Ltd, Kings Lynn) were used for the temperature measurements. Datatrace loggers used thermistors and Ellab wires were type T thermocouples. Note that in Figure 5.12, the thermocouple junction was not at the end of the stainless steel sheath, but at a known distance along its length, and so the TTI tube was taped adjacent to the junction. A common measuring position was assured within a few millimetres for each matching pair of TTI and probe. This enabled the F-values calculated from TTIs and probes to be from virtually the same location.

Sterilisation TTI tubes were approximately 8 mm in length and 2.5 mm outside diameter. The light brown FDP solution can be seen in Figure 5.12, enclosed between two black end plugs of Sylgard 170 elastomer.



Figure 5.12: Ellab Tracksense logger with a sterilisation TTI tube attached to the measuring tip. (picture courtesy of Masterfoods, Kings Lynn)

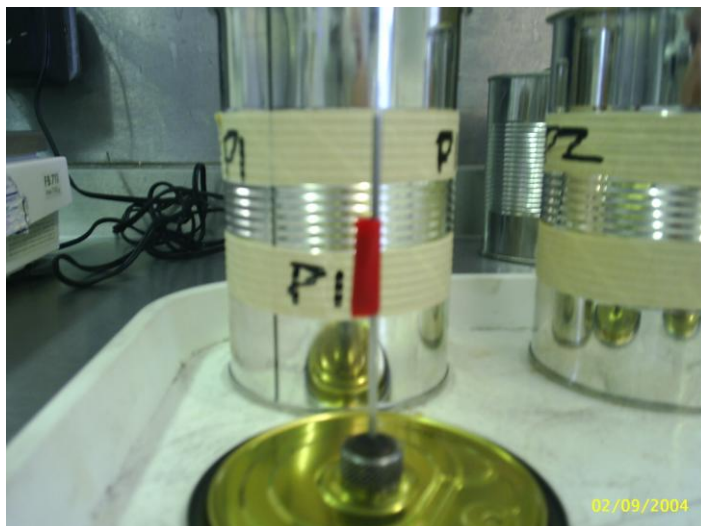

Figure 5.13: Ellab thermocouple housing with a sterilisation TTI tube taped at the point of measurement. (picture courtesy of Baxters, Fochabers)

5.5.1 Measurement of amylase activity rates

Each of the sterilisation TTIs, attached to probes in Figures 5.12 and 5.13, contained approximately 25 μL of the FDP solution. This volume of TTI solution has been found to be sufficient for subsequent amylase activity measurement yet is small enough that the heating

rate of the TTI tube does not affect the measurement (Lambourne and Tucker, 2001; Tucker et al., 2004). Concentration of the FDP was 15 mg/mL of acetate buffer.

Each starch-iodine assay required 20 μ L of the FDP solution. In some TTI tubes, it was not possible to recover 20 μ L from the processed tubes because of losses during extraction of a small aliquot from the tubes. However, at least 15 μ L was recovered from each TTI tube and a pro-rata adjustment in activity was made for the TTIs where less than 20 μ L was recovered.

At this stage of the work, isothermal experiments to measure D-value, described in section 5.4 above, had already used a substantial quantity of the FDP. To evaluate the sterilisation TTI at Masterfoods and Baxters, a more effective assay method was developed from previous experiences with incubated samples at 92°C. Information on the colour changes over the 15-minute incubation period at 92°C had shown that the first 5-minutes of incubation was critical in determining the reaction rate. Incubation beyond 5-minutes was not necessary because the maximum gradient occurred within the first five minutes (see Figure 5.3). This was consistent for all samples, irrespective of the heating time of the TTI tubes.

Thus, to maximise effectiveness of the data obtained in the industrial experiments, the decision was made to optimise the assay by working with only two points on the reaction curve; a time zero point and one at five minutes incubation at 92°C. This assumed linearity in the measured colour change between zero and five minutes of incubation (see Figure 5.14 and compare with Figure 5.3).

Figure 5.3 shows absorbance data at 600 nm using a number of TTI samples incubated up to 15 minutes. Figures 5.4 and 5.5 show the impact on calculated activities and D-value of measuring the gradient between 0 and 2 minutes (Figure 5.4) or between 0 and 5 minutes (Figure 5.5). It is only the unheated FDP that shows a different gradient, which is because the reaction of amylase with starch occurs rapidly at high amylase concentrations. Heated FDP has less active amylase and so the reaction rates with starch are lower and the gradients of absorbance at 600 nm with incubation time are linear over a longer time. This is similar to mesophilic bacterial amylases such as BAA85 and BLA90 used for work in Chapter 4.

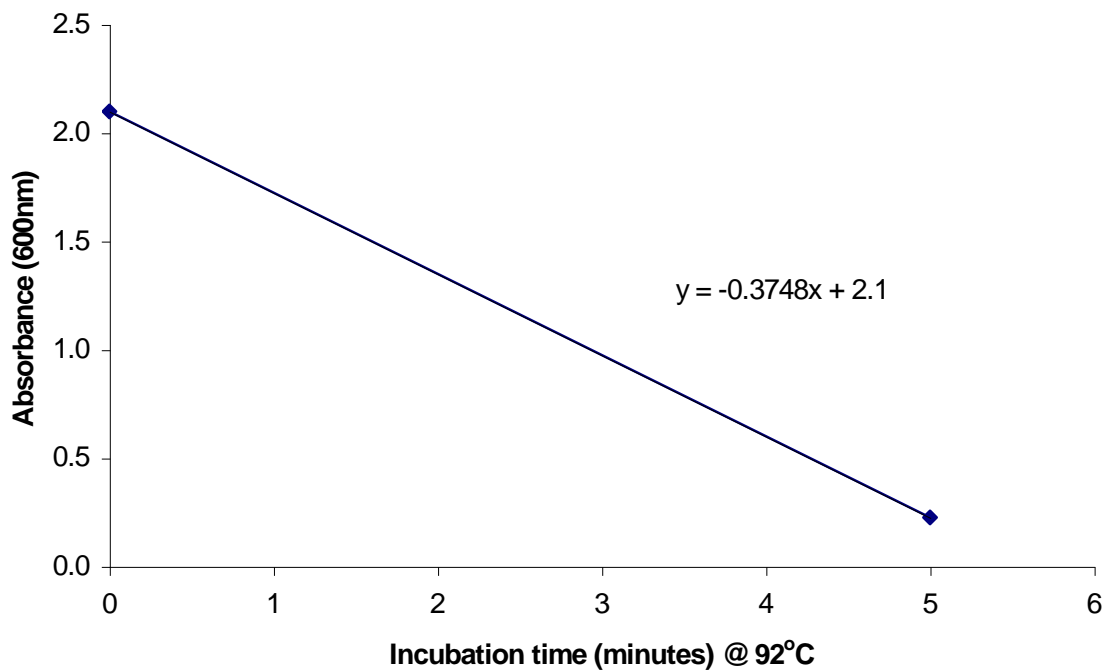

Figure 5.13: Initial activity rate calculation using zero and five minute incubation times at 92°C and assuming linearity between the two points. Activity rate was 0.375.

The ideal scenario for the unheated FDP is to have numerous TTI samples incubating at 92°C and to remove them every few seconds to measure absorbance. By measuring with many samples over the first few minutes of the incubation, it will be possible to generate more points on the discontinuous reaction rate curve, and define the region of maximum gradient with more accuracy. However, this will not work for a manual assay procedure because of the time it takes to carry out one absorbance measurement and also heat transfer issues with short heating times. The potential for using a different amylase assay method is discussed in section 5.6.1 on future work.

Work summarised in Figures 5.3 to 5.5 demonstrated that an assay method that incubated at 92°C for 0 and 5 minutes was of sufficient accuracy for calculating amylase activities. It is likely that an unheated solution of FDP will give a maximum gradient before 5 minutes incubation, and this approach will result in a small underestimation of initial activity. Therefore, a ratio of the initial activity divided by the final activity is likely to underestimate the integrated F-values (see Equation 5.2). Tables 5.2 and 5.3 show that the unheated activity

was 0.261 minutes⁻¹ when calculated over the first 0 to 5 minutes and 0.375 minutes⁻¹ over the first 0 to 2 minutes of incubation at 92°C. It was considered that the positive benefits of using only one 25 µL sample of FDP solution for the assays outweighed the negative of an underestimation in calculated F-value. When more *P. furiosus* material is available it is essential that further work is done on the assay method, particularly for the unheated samples.

Equation 5.2 presents the calculation procedure for F-value based on initial and final amylase activities.

$$F = \int_0^t 10^{\frac{T(t)-T_{ref}}{z}} \cdot dt = D_{T_{ref}} \cdot \log\left(\frac{N_0}{N}\right) \quad 5.2$$

Equation 5.2 can be written in terms of colour measurements at 0 and 5 minutes of incubation at 92°C, since the gradients (amylase activities) were calculated between these times.

Equation 5.3 uses values for colour measurements at 600 nm instead of activities.

$$F = D_{T_{ref}} \cdot \log\left(\frac{C_0 - C_{05}}{C_0 - C_{t5}}\right) \quad 5.3$$

where, C_0 is the colour reading at 600 nm for a unheated control sample after 0-minutes incubation at 92°C,

C_{05} is the colour reading at 600 nm for a unheated control sample after 5-minutes incubation at 92°C,

C_{t5} is the colour reading at 600 nm for a heated sample after 5-minutes incubation at 92°C,

Equation 5.3 shows the calculation procedure for obtaining F-values from the industrial experiments in which sterilisation TTI tubes are inserted into food products. Initial activity is calculated from $(C_0 - C_{05})$ and final activity after a thermal process from $(C_0 - C_{t5})$.

5.5.2 F-value, $D_{121.1}$ and z-value calculation procedures

The benefit of a non-isothermal TTI calibration is that the food products experience this form of time-temperature history during a thermal process. It is not possible for a thermally processed food to rise in temperature instantaneously, and hold that temperature for a period of time before being instantaneously cooled. One exception may be UHT processing of thin liquids in which direct steam injection is used to heat and vacuum cooling is used to cool (CCFRA, 1986). A non-isothermal D- and z-value measurement should have a benefit in that it represents more closely the time-temperature histories that foods experience. Measured D- and z-values by non-isothermal methods should enable more accurate calculation of F-values.

This non-isothermal method used 25 mg/mL FDP solution within silicone TTI tubes and exposed them to various thermal processes where the F-values accumulated at different rates (see Figures 5.9 and 5.11). This was the highest concentration of FDP in acetate buffer used in any of the test described earlier in this chapter. It was used because of the need to start with an initial activity that was high enough to result in measurable activities following the industrial time-temperature processes in Figures 5.8 and 5.10.

Kinetic data (i.e. D- and z-values) were evaluated with a series of coupled equations within an Excel workbook. Equation 5.4 was the basis for the F-value comparison. Time-temperatures were converted to F-values using the left side of Equation 5.4, with z-value as the kinetic parameter, and colour measurements using the right side of Equation 5.4, with D-value as the kinetic parameter.

$$\sum_0^t 10^{\frac{T-T_{ref}}{z}} \cdot \Delta t = D_{T_{ref}} \cdot \log\left(\frac{C_0 - C_{05}}{C_0 - C_{15}}\right) \quad 5.4$$

where, Δt is the time interval used for time-temperature measurements, minutes

t is the total heating and cooling time, minutes

Within the Excel worksheet, the parameters used to determine values for $D_{121.1}$ and z were the sterilisation values (F-values) calculated from the time-temperature data (referred to as F(t-T)) and from the TTI data (referred to as F(TTI)). By comparing F(t-T) and F(TTI) calculations from paired values it was possible to estimate values for $D_{121.1}$ and z that minimised the sum

of the absolute difference between all of the TTI and probe measurements. This was done through an Excel macro using a $D_{121.1}$ of 24 minutes and a z of 10°C as the starting point. The macro stepped through increments in D - and z -value of 0.05 respective units to locate the lowest sum of the absolute difference.

For trial 1 in the Lagarde retort, the minimum value for the average percentage absolute difference between $F(t-T)$ and $F(TTI)$ was 14.83. This was estimated for a $D_{121.1}$ of 21.45 minutes and a z of 9.95°C . Two decimal places (d.p.) for $D_{121.1}$ and z were used in the calculations. Agreement between $F(t-T)$ and $F(TTI)$ for each of the paired values was within 1.5 units of F -value, i.e. minutes. This was considered by the industrial project consortium to be a level of agreement that was sufficiently close in order to have confidence that the sterilisation TTI can be applied to industrial situations.

Table 5.4 and Figure 5.14 provide the raw data for these calculations from data generated in trial 1. Note that in Figure 5.14 the best fit line between paired values of $F(t-T)$ and $F(TTI)$ has been adjusted to go through the origin. This adjustment did not markedly affect the values of $D_{121.1}$ and z .

Table 5.4: F-value data for trial 1; products in pouches processed in a Lagarde steam-air retort. $D_{121.1}$ was 21.45 minutes and z was 9.95°C .

CCFRA	MF	F(t-T)	F(TTI)		%	Abs	% Abs
tube	code	mins	mins	Diff	Diff	Diff	Diff
1	1A	5.97	4.57	1.40	23.5	1.40	23.5
2	2A	4.18	3.57	0.61	14.6	0.61	14.6
3	3A	8.90	10.42	-1.52	-17.1	1.52	17.1
11	3B	9.37	11.14	-1.77	-18.9	1.77	18.9
13	5B	8.44	8.45	-0.01	-0.1	0.01	0.1
			Ave	-0.26	0.39	1.06	14.83

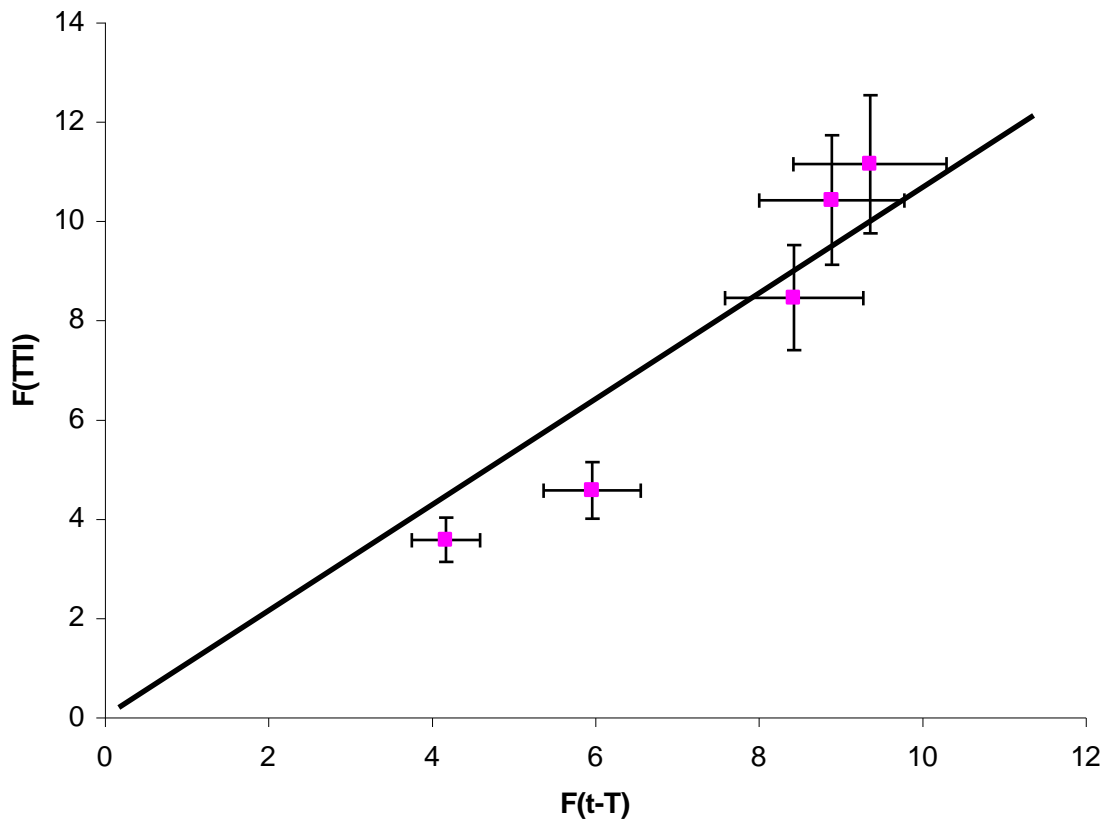

Figure 5.14: Graphical illustration of $F(t-T)$ and $F(TTI)$ for trial 1; products in pouches processed in a Lagarde steam-air retort. $D_{121.1}$ was 21.45 minutes and z was 9.95°C .

For trial 2 in an FMC bar simulator, paired values for $F(TTI)$ and $F(t-T)$ were calculated using the $D_{121.1}$ of 21.45 minutes and z of 9.95°C respectively from trial 1. It can be seen from Table 5.5 and Figure 5.15 that there was good agreement between $F(t-T)$ and $F(TTI)$, although the highest F -values were 30-40% different.

Table 5.5: F-value data for trial 2; products in cans processed in an FMC reel & spiral cooker-cooler. $D_{121.1}$ was 21.45 minutes and z was 9.95°C - values taken from trial 1.

CCFRA	Baxters	F(t-T)	F(TTI)		%	Abs	% Abs
tube	code	mins	mins	Diff	Diff	Diff	Diff
2A	1	6.50	4.86	1.64	25.2	1.64	25.2
2B	1						
3A	2	5.32	4.01	1.31	24.6	1.31	24.6
3B	2	5.32	4.14	1.18	22.1	1.18	22.1
4A	3	4.67	3.27	1.39	29.9	1.39	29.9
4B	3	4.67	3.12	1.55	33.2	1.55	33.2
5A	1	8.53	9.16	-0.63	-7.4	0.63	7.4
5B	1						
6A	2	28.61	16.20	12.41	43.4	12.41	43.4
6B	2	28.61	19.02	9.59	33.5	9.59	33.5
7A	3	3.54	3.76	-0.22	-6.3	0.22	6.3
7B	3						
			Ave	4.54	19.29	4.88	24.75

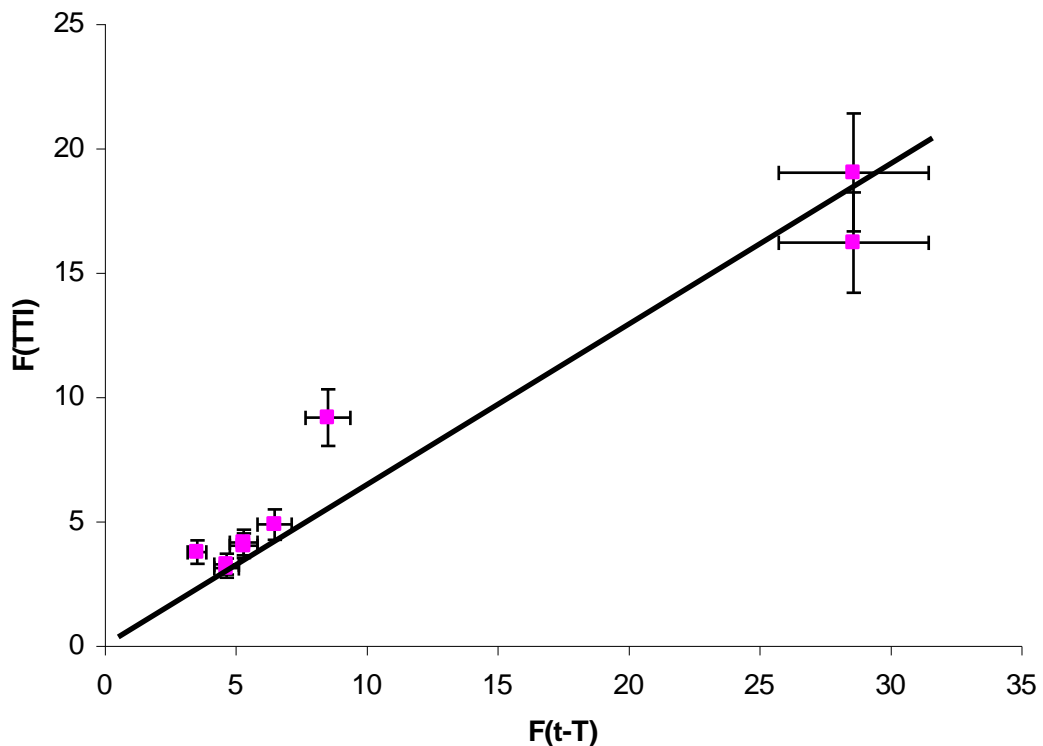

Figure 5.15: Graphical illustration of F(t-T) and F(TTI) for trial 2; products in cans processed in an FMC reel & spiral cooker-cooler. $D_{121.1}$ was 21.45 minutes and z was 9.95°C - as with values from trial 2.

Most of the F(TTI) values are higher in Table 5.5 than their paired F(t-T) values. The two highest F-values in CCFRA tubes 6A, 6B (Baxters code 2) skew the minimum sum of the absolute differences. It is possible to achieve a slightly better agreement between F(t-T) and F(TTI) by adjusting the D and z values in the Excel workbook. Table 5.6 and Figure 5.16 show improved fits in paired F(t-T) and F(TTI) values despite the minimum sum of the absolute differences being similar to those given in Table 5.5. These calculated values are for $D_{121.1}$ of 25.00 minutes and z of 11.5°C, which are quite close to those calculated from trial 1.

Table 5.6: F-value data for trial 2; products in cans processed in an FMC reel & spiral cooker-cooler. $D_{121.1}$ was 25.00 minutes and z was 11.5°C. Lower minimum sum of the absolute differences to that in Table 5.5.

CCFRA	Baxters	F(t-T)	F(TTI)		%	Abs	% Abs
tube	code	mins	mins	Diff	Diff	Diff	Diff
2A	1	6.04	5.67	0.37	6.2	0.37	6.2
2B	1						
3A	2	5.10	4.68	0.42	8.3	0.42	8.3
3B	2	5.10	4.83	0.27	5.3	0.27	5.3
4A	3	4.50	3.81	0.69	15.2	0.69	15.2
4B	3	4.50	3.63	0.87	19.3	0.87	19.3
5A	1	7.23	10.68	-3.45	-47.8	3.45	47.8
5B	1						
6A	2	20.84	18.88	1.96	9.4	1.96	9.4
6B	2	20.84	22.17	-1.33	-6.4	1.33	6.4
7A	3	3.29	4.38	-1.09	-33.3	1.09	33.3
7B	3						
			Ave	-0.61	-11.74	1.74	23.22

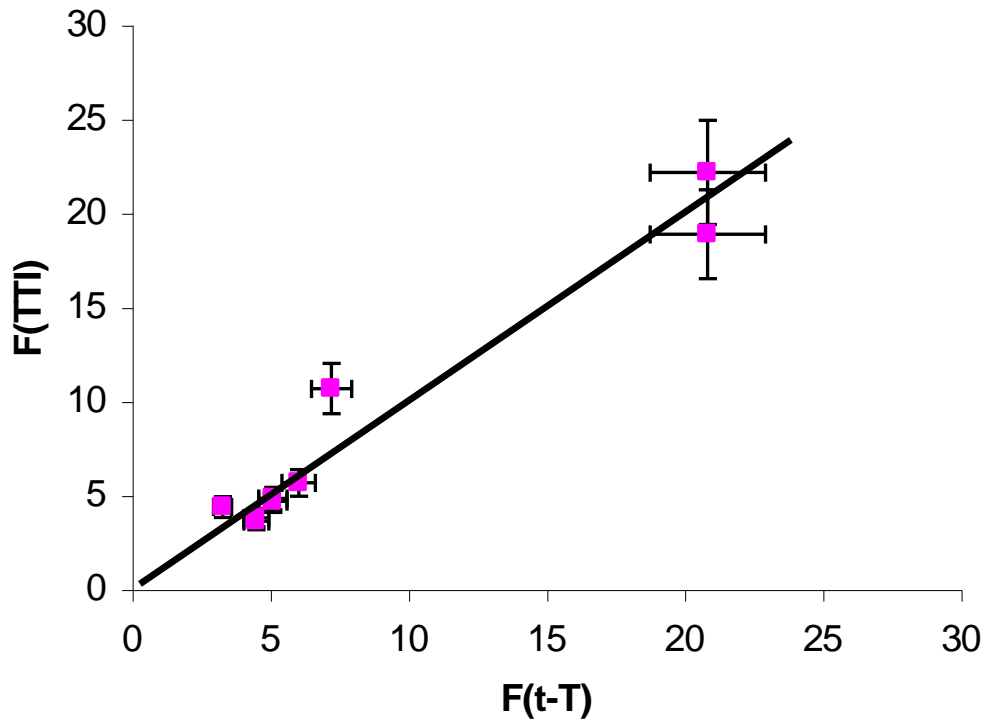

Figure 5.16: Graphical illustration of $F(t-T)$ and $F(TTI)$ for trial 2; products in cans processed in an FMC reel & spiral cooker-cooler. $D_{121.1}$ was 25.00 minutes and z was 11.5°C . Lower minimum sum of the absolute differences to that in Figure 5.15.

Estimated error bars displayed in Figures 5.14 to 5.16 were $\pm 11\%$ on time-temperature F -values (x-scale) and $\pm 12.5\%$ on TTI F -values (y-scale). These errors were calculated from estimated inaccuracies with the measurement systems and variability with the relative experiments. For example, if a temperature sensor is quoted as $\pm 0.5^{\circ}\text{C}$ at the reference or test temperature of 121.1°C , this can be converted to $\pm 11\%$ error in terms of F_0 units. The basis for this calculation was Equation 5.5.

$$\%F_0\text{error} = 100 \times \frac{F_0(T \pm \varepsilon) - F_0(T)}{F_0(T)} \quad 5.5$$

where, F_0 is the sterilisation value specifically for destruction of *C. bot.* spores, minutes

T is the test temperature, $^{\circ}\text{C}$

ε is the temperature offset from the correct test temperature, $^{\circ}\text{C}$

Equation 5.5 was modified to Equation 5.6 by substituting Equation 5.2 for each F_0 term. Absolute values for the positive and negative errors do not equate, with positive errors calculated as slightly higher. Table 5.7 shows how the error increases for temperature offsets between 0 to 1.0°C. Interestingly, the % error is independent of the test temperature, T.

$$\%F_0\text{error} = 100 \times \frac{10^{[(T \pm \varepsilon) - T_{ref}] / z} - 10^{(T - T_{ref}) / z}}{10^{(T - T_{ref}) / z}} \quad 5.6$$

where, T is the test temperature, °C

T_{ref} is the reference temperature, for *C. bot.* spores this is 121.1°C

z is the kinetic factor, for *C. bot.* spores this is 10°C

ε is the temperature offset from the correct test temperature, C°

Table 5.7: Errors in calculated F_0 -value if measured product Temperatures are offset by up to 1°C from a setpoint temperature.

Offset (°C)	% error in F_0 for + offset	% error in F_0 for – offset
0.0	0.00	0.00
0.1	2.33	-2.28
0.2	4.71	-4.50
0.3	7.15	-6.67
0.4	9.65	-8.80
0.5	12.20	-10.87
0.6	14.82	-12.90
0.7	17.49	-14.89
0.8	20.23	-16.82
0.9	23.03	-18.72
1.0	25.89	-20.57

Calculation of errors with TTI F-value measurements is more complicated because of the presence of two activity or three colour measurements for each F-value calculation. Equation 5.3 presents the method for calculating an F-value using the novel sterilisation TTI in FDP form, in which three colour readings are required. These are, C_0 , the colour reading at 600 nm for a unheated control sample after 0-minutes incubation at 92°C, C_{05} , the colour reading for a unheated control sample after 5-minutes incubation, and C_{t5} , the colour reading for a heated sample after 5-minutes incubation. The error bar value chosen for Figures 5.14 to 5.16 was $\pm 12.5\%$ on TTI F-values. This was based on work with amylase pasteurisation TTIs such as BLA90 where two activity measurements are used in the equation for F-value (Tucker et al., 2002). Errors with TTI F-values are discussed in Chapters 1 and 3.

It is likely that the sterilisation TTI, which uses three colour readings, could be subject to higher error values. However, the purpose of the work reported here was to identify a candidate material suitable for the new TTI. Insufficient FDP material was available to carry out replication of the experiments and so precise analysis of errors was not possible.

TTI F-values calculated using the $D_{121.1}$ -value for the sterilisation TTIs were consistently within 1.5 F-value units of those calculated from the time-temperature data. Tables 5.4 and 5.6 show how close the F-values are for a wide range of commercial processes. Most in-pack thermal processes operate at around F_0 -values of 6 to 12 end of heating, and so this agreement between $F(\text{TTI})$ and $F(\text{T-t})$ was an acceptable level of accuracy when used to establish a thermal process. Continuous thermal processes with particles usually operate to substantially higher F_0 -values because of the uncertainty involved with measurements of residence time and heat transfer coefficient (McKenna and Tucker, 1991). Thus, an error of ± 1.5 minutes on a measured F-value in the region of 20-30 minutes would not be an issue for process safety.

5.6 Conclusions and further work

The novel concept of an amylase produced by a microorganism of extreme heat stability was investigated in the work reported here. Such microorganisms exist in volcanic areas where their environment is comprised of hot water pools rich in sulphur and other elements that would be poisonous to most life forms. Some of these extreme microorganisms, referred to as hyperthermophilic microorganisms, produce highly active amylase in order to break down

carbohydrates present their food sources. Extracellular amylase from *Pyrococcus furiosus* was demonstrated to exhibit suitable thermal stability kinetics. These were both a decimal reduction time high enough for residual amylase activity to be measured following a full sterilisation process, but also a z-value close to 10C° that is taken as industry standard for *Clostridium botulinum* spores. This combination of D- and z-values was hitherto unobtainable from an enzyme in solution.

Throughout the testing period for the sterilisation TTI, there were limitations on the numbers of tests that could be done because of low sample mass. This focused the types of tests and limited the replicates. Sufficient testing was conducted to prove that an amylase from *Pyrococcus furiosus* displayed a thermal behaviour that was suitable for use as a sterilisation TTI. It would be necessary to procure a much larger sample of this amylase in order to conduct more detailed isothermal and non-isothermal kinetic testing and understand the TTI more fully. This should be part of a future project.

Some isothermal kinetic data were collected to determine the D-value at 121°C but it was non-isothermal methods that were used more extensively. The method of non-isothermal calibration was a quicker and more efficient method to determine the D and z values for a TTI system. Requirements for a non-isothermal calibration were to attach sufficient numbers of TTIs to temperature sensors so that F(t-T) and F(TTI) were calculated for each paired value. No absolute minimum number is recommended, however, ten to fifteen paired values over the 3 to 15 F₀ range provide sufficient data to obtain accurate D- and z-values. This has a distinct advantage over isothermal methods because it can be done as part of a thermal processing trial and need not be a lengthy exercise of its own. Thus, the approach to calibrating the TTI sensors can be made similar to that for calibrating temperature sensors in which the sensor readings are compared against a master temperature indicator during the first trial.

D-values at 121°C were measured between 18 and 24 minutes for the isothermal calibrations and 24.5 and 25.0 minutes for the non-isothermal calibration. F-values measured with the sterilisation TTI compared within 1.5 F-value units to the probe F-values over most of the measurement range. The one exception was for the single F₀-value of 28 minutes where the TTI system gave a lower value. This can be explained by this value being outside of the upper measurement range. It may be that the sterilisation TTI cannot be used to measure more than one-log reduction in amylase activity at the 25 mg/mL FDP concentration (further diluted to 5

mg/mL for assay purposes). Conventional pasteurisation TTIs using a pure amylase source for the starting material allow a measurement of at least two-log reductions in amylase activity. Obtaining high accuracy at high F_0 -values is not important for process safety where the operating region is in the lower range towards F_0 3.

A z-value was not measured from an isothermal calibration because of limitations with the mass of FDP available. These tests would have required at least four D-value tests to be conducted. Instead, non-isothermal calibration was used for measuring the z-value, because of its greater efficiency with sample requirements. The z-value from the first set of thermal processes came out at $9.95 \pm 1.5^\circ\text{C}$. This z-value was close to the *Clostridium botulinum* value of 10°C .

Results presented in this chapter were the culmination of three years of effort in characterising the sterilisation TTI in solution. Much of this time was involved with obtaining amylase from the hyperthermophilic microorganism *Pyrococcus furiosus*, which proved difficult for the reasons given earlier. Having obtained a working sample, the results for its heat stability were shown to be suitable for use as a sterilisation TTI.

5.6.1 Further work

There are two main objectives for a TTI-based thermal process measurement system; firstly to measure a process value in order that a food product can be produced safely, and secondly to optimise processes if the values are too high. The measurement range for the sterilisation TTI allowed both these objectives to be realised. Further testing of the sterilisation TTI will be required to determine the measurement limits more precisely and assign levels of confidence in the F-values over this measurement range.

Heat stable amylase from *Pyrococcus furiosus* was demonstrated as a suitable material for use as a TTI for thermal sterilisation processes. Due to the small sample sizes available it was not possible to complete all the testing appropriate for a new TTI. Further experimental work is required in a number of areas to address the questions that arose during the research:

- It will be necessary to obtain larger quantities of FDP to enable further testing. Conditions used in the batch fermentation may not have been optimised for amylase production and

may have resulted in detrimental by-products (e.g. proteases). Continuous fermentation could be used for greater yields and consistency.

- Determine the best conditions for storing the FDP and of the filled sterilisation TTI tubes. This is important to prevent loss in activity during transportation to/from industry trials. It was assumed that storing the TTI tubes in acetate buffer, which were then put into a freezer, was the best method since this had been used with other TTI systems.
- Purification - how far to go? The end point for work reported here was FDP with minimal purification. Reduction in activity was found when the sterilisation TTIs were stored chilled, which was thought to be caused by proteases acting on the amylase. The FDP was not a pure amylase and so other by-products of the fermentation will be present. Some of these may be detrimental to the amylase.
- What variability should be expected for the sterilisation TTI? It has many applications to industrial thermal processes and so it will be necessary to understand the accuracy of F-values estimated from the TTIs.
- How to guarantee long term supply of the FDP with reproducible heat stability properties. *Pyrococcus furiosus* fermentation may not be the best method to produce heat stable amylase. There are many reports of the gene being expressed in bacteria such as *E. coli* or in yeast and mould. Reports suggest the amylase from an *E. coli* retains its heat stability but it has not been tested in the same way as for a sterilisation TTI. Early results are given in Chapter 6 for thermostable amylase produced from a yeast culture where the amylase producing gene was expressed into the yeast cells.

CHAPTER 6: FUTURE TTI PROJECTS

‘The only way to discover the limits of the possible is to go beyond them into the impossible’

Arthur C. Clarke

Chapter 5 described a series of tests to develop an innovative TTI suitable for applications to sterilisation processes. This has considerable potential as a TTI for measuring F-values in continuous sterilisation processes and in many other applications such as continuous rotary canning. The tests concluded that an α -amylase from *Pyrococcus furiosus* had suitable heat stability characteristics, however, production of the amylase from this organism proved troublesome because of the extreme conditions in which it survives. Therefore, two routes for production of a heat stable amylase were explored during the latter stages of this thesis work.

Chapter 5 dealt with amylase produced directly from the *Pyrococcus furiosus* organism and the media conditions required to encourage this organism to produce amylase. Samples of a 1-litre fermentation broth were obtained from the University of Georgia as a means of fast tracking the work. This was proven to be successful but difficult to reproduce in larger quantities. Work is now ongoing at the University of Birmingham to grow *Pyrococcus furiosus* using continuous fermentation techniques that have the potential to increase the yield of thermostable amylase. One of the challenges is to encourage *Pyrococcus furiosus* to produce its cocktail of enzymes, of which it is known that around 80 are produced, but with a preference to production of the thermostable amylase. Results from this work are promising but are not included in this thesis.

The alternative technique, which is described in this chapter, is to clone the amylase producing gene into a different microorganism that can be grown in more moderate laboratory conditions. This has many benefits over that of a *Pyrococcus furiosus* fermentation that must take place under extreme laboratory conditions. By selecting the gene responsible for amylase production, the secretion of enzymes from the host cell should have a preference for the thermostable amylase. Concentration of amylase should be proportionally higher and the

presence of amylase degrading enzymes such as proteases should be reduced. Thus, purification steps for the TTI that involve freeze drying and taking the freeze dried powder up into a buffer should result in greater yields. It is also easier to grow the chosen microorganism in conventional laboratory fermentation equipment, which has a major advantage for the ultimate aim of manufacturing the sterilisation TTI for widespread use in the food industry. CCFRA does not operate a fermentation laboratory suitable for growing hyperthermophilic microorganisms but is well placed to grow mesophilic bacteria, yeast and mould.

6.1 Review of literature on gene expression

Gene expression has emerged as one of the most important scientific techniques of this age. It is surrounded with controversy because it attempts to combine the strengths of one organism with those of another, and in doing so creates a new organism. Its origins are in plant molecular biology in which disease-resistant, drought-resistant or heavy-cropping strains can be developed.

Gene expression, also called protein expression or expression, is the process by which a gene DNA sequence is converted into the structures and functions of a cell (Wikimedia, 2006). Gene expression is a multi-step process that begins with transcription of DNA, the building blocks of genes, into messenger RNA. It is then followed by post transcriptional modification and translation into a gene product, followed by folding, post-translational modification and targeting. The amount of protein that a cell expresses depends on the tissue, the developmental stage of the organism and the metabolic or physiologic state of the cell. The thermostable amylase required for the sterilisation TTI was one such protein.

Protein encoded for by a gene can be expressed in increased quantity. This can come about by increasing the number of copies of the gene or increasing the binding strength of the promoter region. Often, the DNA sequence for a protein of interest will be cloned or subcloned into a plasmid containing the lac promoter, which is then transformed into the bacteria, *Escherichia coli*. Addition of IPTG (a lactose analog) causes the bacteria to express the protein of interest. IPTG is a common abbreviation for Isopropyl β -D-1-thiogalactopyranoside, a molecular biology reagent, which has a molecular weight of 238.3. However, this strategy does not always yield functional proteins, in which case, other organisms or tissue cultures may be

more effective. The yeast, *Saccharomyces cerevisiae*, is often preferred to bacteria for proteins that undergo extensive post-translational modification.

In the research conducted here, a heat stable amylase was required from *Pyrococcus furiosus* but with a preference for growing conditions suited to use in general microbiological laboratories. This required the amylase-producing gene to be expressed in a mesophilic organism such as a bacterium, yeast or mould. There was a reluctance on behalf of some food manufacturing companies to go down this path, particularly if the bacterium was *Escherichia coli*.

Some of the relevant literature to gene expression of proteins from hyperthermophilic organisms is reviewed. The focus of the papers presented here is in relevant proteins to the α -amylase produced by *Pyrococcus furiosus*, or related organisms.

Vieille and Zeikus (2001) reviewed properties of several hyperthermophilic enzymes (sometimes referred to as thermozyms) synthesised by hyperthermophiles. The enzymes were inherently thermostable, optimally active at high temperatures, and shared the same catalytic mechanisms with their mesophilic counterparts. When cloned and expressed in mesophilic hosts, thermozyms usually retained their thermal properties, indicating that these properties were genetically encoded. Sequence alignments, amino acid content comparisons, crystal structure comparisons, and mutagenesis experiments indicated that thermozyms were very similar to their mesophilic homologues. The molecular mechanisms involved in protein thermostabilisation were discussed, including ion pairs, hydrogen bonds, hydrophobic interactions, disulfide bridges, packing, decrease of the entropy of unfolding, and intersubunit interactions. Current uses and potential applications of thermophilic and thermozyms as research reagents and as catalysts for industrial processes were described. This was an area of rapid growth.

Findings on the biochemical and molecular features of several thermozyms were presented by Zeikus et al. (1998). This included; α -amylase and amylopullulanase used in starch processing, glucose isomerase used in sweetener production, alcohol dehydrogenase used in chemical synthesis, and alkaline phosphatase used in diagnostics. The corresponding genes and recombinant proteins were characterised in terms of sequence similarities, specific

activities, thermophilicity, and unfolding kinetics. All these thermozyms displayed higher stability and activity than their counterparts currently used in the biotechnology industry.

Melasniemi and Paloheimo (1989) cloned an α -amylase-pullulanase gene from *Clostridium thermohydrosulfuricum* DSM 3783 in *Escherichia coli* on a 7.0 kb EcoRI fragment using a lambda vector. The gene produced active thermostable α -amylase-pullulanase, seemingly mostly a soluble intracellular enzyme in *E. coli*. Despite the marked degeneration of its constituent polypeptides, the apparent temperature optimum of the enzyme (80-85°C) was only some 5°C lower and the heat stability the same as that of the extracellular α -amylase-pullulanase produced by the native host.

Lioliou et al. (2004) reported that the genome sequence analysis of *Thermus thermophilus* HB27, a microorganism with high biotechnological potential, had recently been published. Enzymes produced by *Thermus thermophilus* HB27 were found to be more thermostable than their mesophilic homologues and were also more resistant to chemical agents, properties that made them extremely attractive for industrial processes. Recent structural comparisons among mesozymes and thermozyms had validated numerous protein stabilising mechanisms including hydrophobic interactions, packing efficiency, salt bridges, hydrogen bonding, reduction of conformational strain, loop stabilization, resistance to covalent destruction and binding to RNA. This report confirmed the fact that most thermal studies resulted in similar or higher levels of heat stability for recombinant proteins.

Jorgensen et al. (1997) cloned, sequenced, and expressed the gene for the extracellular α -amylase from *Pyrococcus furiosus* into *Escherichia coli* and *Bacillus subtilis*. The gene was 1,383 bp long and encoded a protein of 461 amino acids. The open reading frame of the gene was verified by microsequencing of the recombinant purified enzyme. The deduced amino acid sequence was 25 amino acids longer at the N terminus than that determined by sequencing of the purified protein, suggesting that a leader sequence was removed during transport of the enzyme across the membrane. The recombinant α -amylase was biochemically characterised and showed an activity optimum at pH 4.5, whereas the optimum temperature for enzymic activity was close to 100°C. α -amylase showed sequence homology to the other known α -amylases and belonged to family 13 of glycosyl hydrolases. This extracellular α -

amylase was not homologous to the sub-cellular α -amylase previously isolated from the same organism.

A related piece of work by Tachibana et al. (1997) studied the enzyme 4-alpha-glucanotransferase (GtpK), which produces cyclic alpha-1,4-glucans (cycloamyloses) by transglycosylation. Cycloamyloses are potentially useful in the chemical, pharmaceutical and food industries because of their ability to form inclusion complexes with specific molecules and thereby alter their solubility, stability and reactivity properties. For industrial production of these compounds, an enzyme with increased thermal stability is required; therefore, a GtpK from the hyperthermophilic archaeon *Pyrococcus sp. KOD1* was studied. Cloning of the GtpK gene revealed a nucleotide sequence consisting of 1,973 bp, encoding a 653 amino acid residue protein with a molecular weight of 76,693 Da. GtpK was expressed in *Escherichia coli*, and the protein product was purified and reacted with maltooligosaccharides (from maltose to maltoheptaose) to form glucose and various maltooligosaccharides, containing more sugar units than the original substrate. Optimum temperature and pH were 100°C and 6-8, respectively, and the enzyme remained stable after heating at 100°C for 30 minutes. GtpK exhibited 68.3 and 36.0% homology to α -amylases from *Pyrococcus furiosus* and *Dictyoglomus thermophilum* respectively. These three homologous enzymes did not share the conserved regions observed in other enzymes of the α -amylase family. Therefore, it was suggested that these two α -amylases and GtpK should be classified as a new family of starch-degrading enzymes.

The gene for *Pyrococcus furiosus* amylopullulanase (APU) was cloned, sequenced and expressed in *Escherichia coli* by Dong et al. (1997). The gene encoded a single 827-residue polypeptide with a 26-residue signal peptide. The protein sequence of this glycosidase had very low homology (17-21% identity) with other APU and enzymes of the α -amylase family. In particular, none of the consensus regions present in the α -amylase family could be identified. *P. furiosus* APU showed similarity to 3 proteins, including the *P. furiosus* intracellular α -amylase and *Dictyoglomus thermophilum* α -amylase A. The mature protein had a molecular weight of 89,000. The recombinant *P. furiosus* APU remained folded after denaturation at temperatures of less than or equal to 70°C and showed an apparent molecular weight of 50,000 in SDS-PAGE. Denaturing temperatures in excess of 100°C were required for complete unfolding. The enzyme was extremely thermostable, with an optimal

activity at 105°C and pH 5.5. Ca²⁺ ions increased the enzyme activity, thermostability, and substrate affinity. The enzyme was highly resistant to chemical denaturing reagents, and its activity increased up to 2-fold in the presence of surfactants.

An extracellular α -amylase gene from the hyperthermophilic archaeon *Pyrococcus woesei* was cloned and sequenced by Frillingos et al. (2000). The 1.4-kb protein-coding sequence was identical to that of the corresponding α -amylase gene of the closely related species *P. furiosus*. By using a shuttle cloning vector for halophilic bacteria, the *P. woesei* α -amylase was expressed in the moderate halophile *Halomonas elongata*, under the control of a native *H. elongata* promoter. The hyperthermophilic amylase activity expressed in the halophilic host was recovered completely in the crude membrane fraction of cell homogenates. However, thermal stability, metal ion interactions, optimal temperature and pH values for the crude and purified recombinant α -amylase were comparable with those of the native pyrococcal enzyme. The *P. woesei* amylase activity expressed in *H. elongata* was consistently detected in the cells upon growth on a wide range of NaCl concentrations.

Expression of an extracellular α -amylase from *Pyrococcus furiosus* in *Escherichia coli* was also investigated by Wei et al. (2003). The recombinant plasmid, pET-amy(sig+) was constructed by inserting the amplified DNA segment from *P. furiosus* into the expression vector pET28a. The enzyme expressed in *E. coli* without the signal peptide had similar properties to the α -amylase produced by *P. furiosus*, with pH and temperature optima of 5.0 and 95°C, respectively. The enzyme retained >50% of its activity after incubation at 121°C for 1 hour.

Yang et al. (2004) conducted genomic analysis of *Pyrococcus furiosus* to reveal the presence of thermostable amylase. This amylolytic enzyme, designated PFTA (*Pyrococcus furiosus* thermostable amylase), was cloned and expressed in *Escherichia coli*. The recombinant PFTA was extremely thermostable, with an optimum temperature of 90°C. This compared favourably with that from *Pyrococcus furiosus*. The substrate specificity of PFTA suggested that it possessed characteristics of both α -amylase and cyclodextrin-hydrolyzing enzymes.

Chapter 5 of this thesis proved that an amylase from *Pyrococcus furiosus* could exhibit thermal properties suitable for applications as a sterilisation TTI. Generating a repeatable

supply of thermostable amylase had proved a challenge by the method of harvesting the cocktail of enzymes secreted by *Pyrococcus furiosus*. In order to achieve a pure form of amylase, without competing enzymes present, techniques for expressing the thermostable α -amylase from various mesophilic bacteria were of great interest. The gene responsible for producing this amylase was investigated in order to provide an alternative fermentation method that did not require the adverse conditions of a fermentation at 100°C in a reducing atmosphere. It was possible to spend a short time within the TTI LINK project investigating whether the gene expression route could work. This was carried out in collaboration with Unilever Research in their Vlaardingen Laboratories.

6.1.1 Food industry acceptability

Pyrococcus furiosus itself is not a food poisoning organism and so an amylase preparation from the extracellular fermentation by-products was not considered by food companies to represent a risk. Ideally, any microorganism used to produce an enzyme for use as a processing aid in food industry applications should be non-toxic. This applied equally to the work in finding an organism for producing the thermostable amylase for the sterilisation TTI. Unfortunately, the most common bacteria into which the amylase producing gene was expressed was *E. coli*. The high toxicity of *E. coli* 0175 made this an unattractive host organism for food companies to work with.

The *E. coli* route to securing a thermostable amylase was discussed at one of the AFM194 LINK project meetings. The industrial consortium that guide this project thought it would be difficult to convince their senior management that using an amylase from *E. coli* did not represent a food safety risk. Recent experiences with the GM debate in the UK had resulted in food products manufactured using GM technology being withdrawn from retailers shelves (Soil Association, 2005). This has left its mark on the UK food industry.

Fortunately, there are alternatives to *E. coli* that are more acceptable to the food industry. The common yeast, *Saccharomyces cerevisiae*, is reported to offer flexibility to operate as an optimised cell factory for the production of proteins such as amylase (Vasavada, 1995). The group at Unilever Vlaardingen (Verrips et al., 2000) used *Saccharomyces cerevisiae* for the production of a fungal cutinase, which is a lipase produced by fungi to break down the cuticle layer of plants. Cutinase is an enzyme with applications for laundry cleaning products, hence

the Unilever interests, but requires protein engineering to optimise its performance and stability in the presence of detergent components. This is achieved within the cell environment.

Expertise in genetic modification techniques was therefore available at Unilever Vlaardingen and offered to the AFM194 project. The first stage was to identify a suitable yeast cell in which the gene manipulation had taken place successfully. A series of screening experiments were done using around fifty different types of *Saccharomyces cerevisiae* cells. Synthetic gene encoding of the *Pyrococcus furiosus* extracellular amylase took place in *Saccharomyces cerevisiae* under the control of the galactose inducible GAL7 promotor (Schaffers, 2007). Transformants were screened for the production of thermostable amylase. One yeast cell showed promise and was the focus of further study to generate the thermostable amylase.

6.2 Evaluation of the Unilever yeast amylase

The first experiments to produce thermostable amylase for use as the liquid in a sterilisation TTI were done in shake flasks by Ingrid Schaffers at Unilever Vlaardingen. Most of the thermostable amylase was extracellular and therefore contained in the fermentation broth. Measured activity of this amylase was high in comparison with amylases from mesophilic bacterial amylases such as *B. licheniformis* or *B. amyloliquefaciens*. This made the fermentation broth sufficiently active that it could be used directly as a TTI solution without purification. At this stage of the work the experiments were intended simply to determine if the amylase possessed a level of heat stability that was high enough to survive a commercial sterilisation process with measurable activity.

Fermentation broth from a *Saccharomyces cerevisiae* shake flask fermentation provided the liquid used for determination of the amylase heat stability. Yeast cells were filtered out and the filtrate centrifuged to remove any remaining cells. The cells were discarded. Heating tests at 121°C were conducted in a well stirred oil bath using the fermentation liquid enclosed in glass capillary tubes. Heating times of 0, 2, 4, 6, 8, 10 and 12 minutes were used. These times were chosen because the minimum sterilisation process for foods is 3 minutes at 121.1°C (DoH, 1994) but many food companies increase processes to 6-12 minutes at 121.1°C. Hence,

the heating times represented commercial practice. The experiments looked for a reduction in amylase activity as the heating time at 121°C increased from 0 to 12 minutes.

Methods for assaying the amylase activities arising from each set of heating tests were similar to those described in Chapter 5. Amylase activity was measured by incubating at 92°C and pH 5.0 a mixture of 20 µL of 1% soluble starch with 20 µL of 100 mM acetate buffer and 20 µL of the fermentation liquid. Incubation was for a range of time intervals up to 25 minutes. The reaction was stopped by the addition of 1 mL of ice cold water and the colour developed by addition of 15 µL of an iodine solution (4% potassium iodide and 1.25% iodine solution).

Figure 6.1 presents examples of the kinetic evaluation of the thermostable amylase, for heating times at 121°C of 0, 4 and 12 minutes. Minimal or no reduction in amylase activity was measured for these heating times. Results for other heating times at 121°C (2, 6, 8 and 10 minutes) did not show any reduction in amylase activity and so are not shown here.

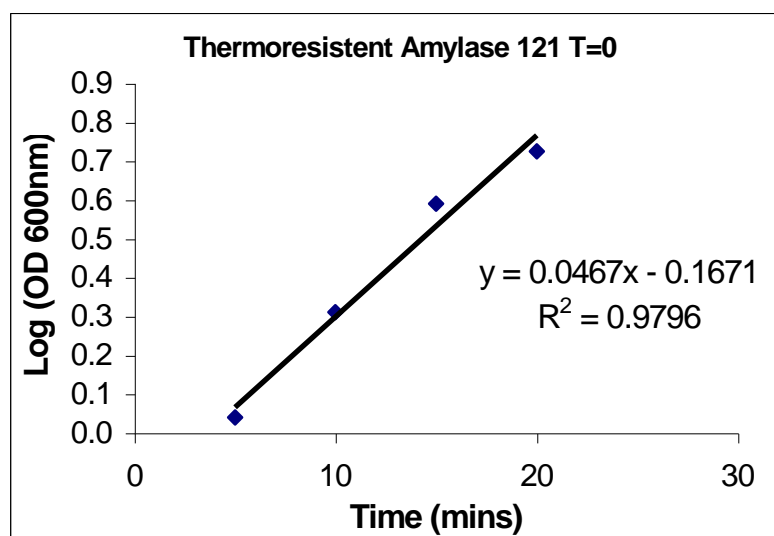

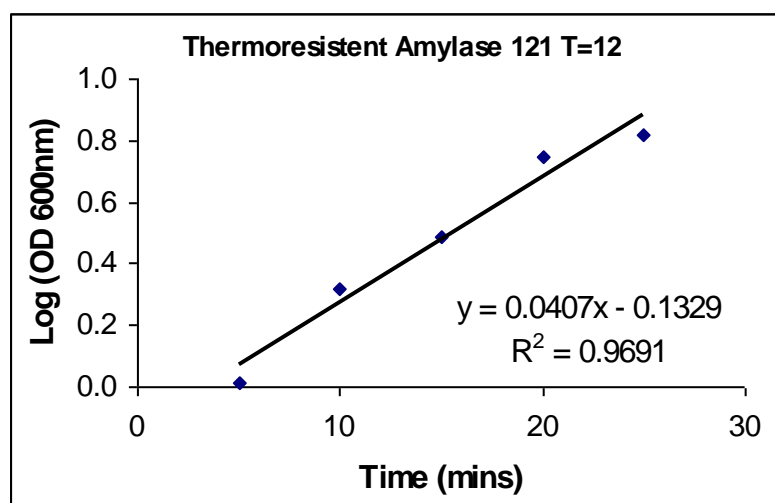
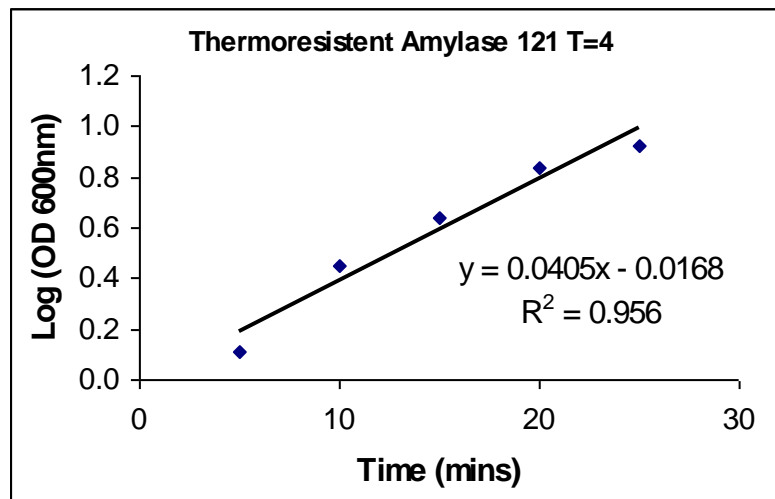

Figure 6.1: Kinetic evaluation of the thermostable amylase, for heating times at 121°C of 0, 4 and 12 minutes. Starch-iodine assay at 92°C was used. (Courtesy of Unilever Vlaardingen)

6.2.1 Tubular heat exchanger TTI trial

The same fermentation liquid was used in an industrial TTI trial on a continuous tubular heat exchanger at the Unilever factory in Duppigheim, France. This trial was done at a similar time to the heating tests at 121°C described above, and before results were available on heat stability. At this point in time, it was considered that the industrial trial might provide confirmation of the approximate levels of amylase heat stability. The trial was set up to

evaluate the feasibility of introducing and recovering the TTI 'in-flow sensing devices' and so only a small number of TTI tubes were included in the tests.

A Goulash soup with 10 mm particles of various vegetables was used for the product. Silicone TTI tubes were made using the method described in Chapter 2. Each tube contained at least 40 μL of fermentation broth, which was sufficient for the number of incubation tests that were required from each tube (method for dilution of the liquid is described in Chapter 5). The estimated thermal process for the Goulash soup was approximately F_0 23 (estimated at $18 < F_0 < 40$) in the heating, holding and cooling tubes. This estimation was made from the measured Goulash temperatures and flowrates. It assumed the centreline Goulash velocity was double that of the mean velocity calculated from the flowmeter readings. Potential variation in calculated F_0 were significant for this continuous flow system because of the uncertainties in knowing the flow behaviour through the exchanger and holding tubes, together with the instability issues with the holding tubes. However, the minimum F_0 was estimated to be no less than 18.

All of the TTI tubes were recovered from the Goulash soup by spreading the soup onto a stainless steel table and hand sorting. These tubes were taken back to CCFRA for analysis. When the thermostable amylase was extracted from the TTI tubes and assayed, no reduction in amylase activity was measured. Results thus confirmed that the amylase was very heat stable.

The laboratory heating tests and the continuous flow experiment had highlighted that the Unilever yeast amylase showed a level of heat stability (F_0 23) greater than that required for the measurement of commercial food sterilisation processes ($3 < F_0 < 20$). Although this was not the ideal finding, it was considered easier to adjust the level of heat stability downwards rather than to increase it.

The next experiments were set up to investigate whether it was possible to reduce the amylase heat stability in a controlled way.

6.2.2 Decreasing the heat stability of the Unilever yeast amylase

A number of candidate chemicals were tested for their ability to destabilise the Unilever yeast amylase. These all had the effect of binding up the metal ions, primarily calcium ions, and in doing so, making the amylase molecule more susceptible to cleavage (Koch et al., 1990; Ladermann et al., 1993; Brown et al., 1990). Table 6.1 presents the combinations of buffer solutions used to dissolve the thermostable amylase FDP and the destabilising chemicals tested. The sterilisation TTI solutions were made from 100 mg of FDP dissolved in 1 mL of buffer solution. Heating tests used 20 μ L of the FDP solution enclosed within a glass capillary tube, and immersed in a glycerol bath at 121°C for either 2 or 12 minutes. After heating, the FDP solution was diluted 1:10 in buffer solution in order that 20 μ L was available for each of the assays required to generate an activity curve at different incubation times. This procedure was the same as that described in Chapter 5.

Table 6.1: Amylase activity after 100 mg solutions of FDP dissolved in 1 mL of buffer with different destabilising chemicals.

Buffer solution	Destabilising chemical	% activity after 2 minutes at 121°C	% activity after 12 minutes at 121°C
10 mM phosphate, pH 7.0	None	-	100
	1 mM EDTA	100	-
	0.1 mM EDTA	80	-
100 mM phosphate, pH 7.0	None		100
	10 mM EDTA	0	
	1 mM EDTA	70	
	0.1 mM EDTA	70	
	10 mM DTT	20	0
100 mM citrate-phosphate, pH 7.0	None		100
	10 mM EDTA		0
50 mM Tris-HCl, pH 8.6	None	60	

From these screening experiments, it was decided that the most promising system for reducing the heat stability of the thermostable amylase was with the amylase dissolved in 100 mM phosphate buffer with 0.1 mM EDTA added. Experiments were set up to heat glass capillary tubes containing amylase (FDP 100 mg/mL in 100 mM Phosphate buffer, pH 7.0) with 0.1 mM EDTA, and heated for 2-12 minutes at 121°C in a glycerol bath. After removal from the glycerol bath the amylase solution was diluted 1 in 10 with 10 mM sodium acetate buffer pH 5.0 with 1 mM CaCl₂. 20 µL was required for each assay.

Table 6.2 shows the gradients calculated from each of the heating times at 121°C. Initial activity of $-0.141 \text{ minutes}^{-1}$ was taken from the mean of five samples, which are also given in Table 6.2. Gradients were calculated in three ways:

- the best fit over the straight portion of the activity curve,
- between 0 and 2 minutes incubation at 92°C and
- between 0 and 10 minutes incubation at 92°C.

Shape of the activity curves was similar to that shown in Figure 5.3 for the discontinuous assay.

Table 6.2: Gradients (rates) calculated from each amylase heating time at 121°C. 100 mg/mL FDP in 100 mM Phosphate buffer, pH 7.0, with 0.1 mM EDTA was used to reduce thermostability. Initial activity of $-0.141 \text{ minutes}^{-1}$ was taken from the mean of five samples.

Heating time at 121°C (minutes)	- Rate (best fit), minutes ⁻¹	- Rate (0/2), minutes ⁻¹	- Rate (0/10), minutes ⁻¹
0.0 (mean value)	0.1410	0.1380	0.1380
2.0	0.1291	0.1425	0.1325
2.5	0.1253	0.0875	0.1245
5.0	0.0881	0.0590	0.0896
7.5	0.0523	0.0300	0.0551
10.0	0.0387	0.0190	0.0392
12.0	0.0353	0.0205	0.0416
0	0.1360	0.1610	0.1350
0	0.1398	-	-
0	0.1400	0.1380	0.1370
0	0.1390	0.1330	0.1370
0	0.1450	0.1350	0.1440
Mean initial rate	0.1410	0.1350	0.1390

Figure 6.2 shows data from the three different ways of calculating the gradient from the discontinuous activity curve using the data from Table 6.2. Only minor differences were found between the three methods, which was insignificant in the context of the objectives of achieving a destabilised thermostable amylase. Decimal reduction time at 121°C for the destabilised amylase ranged between 10.8 and 14.1 minutes.

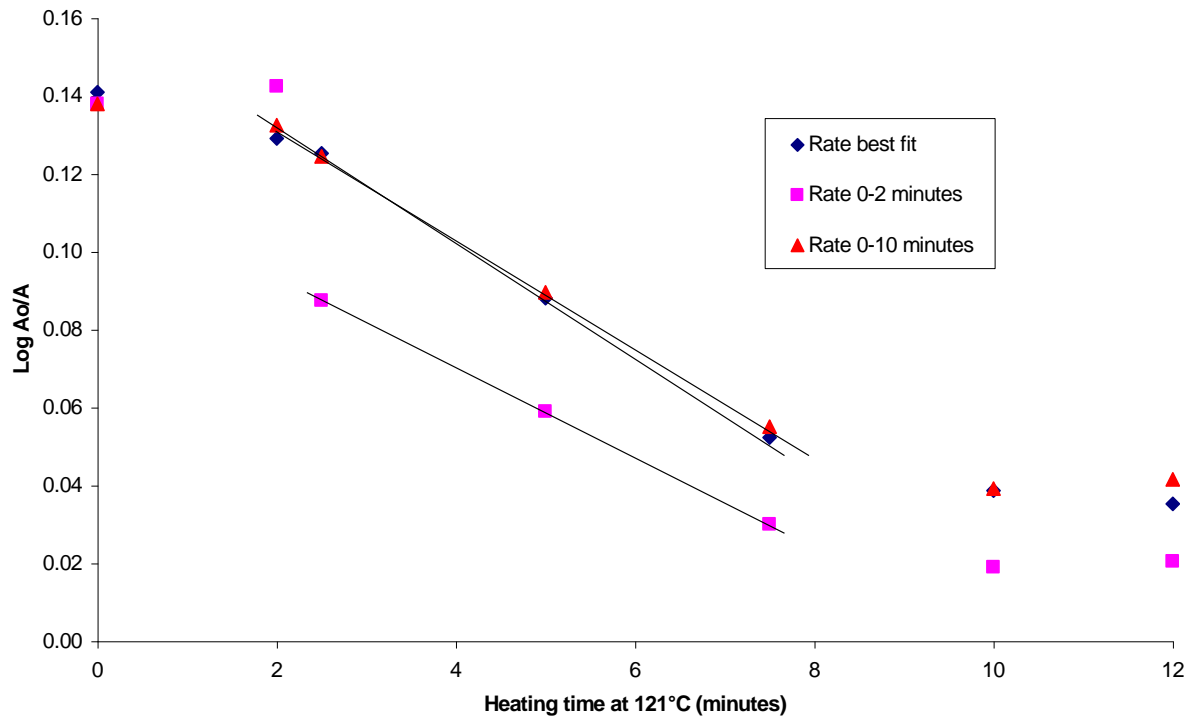

Figure 6.2: Log Ao/A for thermostable amylase (FDP 100 mg/mL in 100 mM Phosphate buffer, pH 7.0) with 0.1 mM EDTA added, against heating times at 121°C. Decimal reduction time was between 10.8 and 14.1 minutes.

Data in Figure 6.2 shows that the log-linear portion of the graph extends only to around 8-10 minutes. This is of significance when applying the sterilisation TTI to food processes with F_0 value greater than 8-10 minutes. These data points are intended to illustrate that the Unilever yeast amylase can be reduced in its high levels of thermostability. There are no repeat experiments to substantiate these data neither are there any heat stability data taken at different temperatures to determine the z-value. This needs to be done in a subsequent study.

6.3 Further work

Data presented above suggests that there is now a potential route to securing large quantities of thermostable amylase with a level of heat stability close to that required for measuring commercial food sterilisation processes. By cloning the amylase producing gene into a

common yeast cell it was possible to generate sufficient quantities of amylase for extensive thermal testing. This had proved difficult with a direct *Pyrococcus furiosus* fermentation.

The challenge is now to confirm the data in Figure 6.2 with a fresh sample of FDP, to understand the inherent variability with the data, and to determine the measurement range of this TTI system. In addition, it will be necessary to carry out a similar set of heating experiments at different temperatures in order to calculate the sensitivity of this amylase TTI to changing temperature. In conventional thermal processing analogy this is quantified with the z-value. No z-value data was generated in the data presented here because of time constraints.

It is hoped that the z-value for the Unilever yeast amylase will lie in the range 8-14°C, which have been measured with amylases from other microbiological origin, and reported in earlier chapters of this thesis. A z-value close to 10°C seems to be a property of bacterial amylases that can be achieved when careful selection of concentration and buffering solution is made. This makes it unique as a time-temperature integrator for measuring process values that can be converted to log reductions for spores of certain microorganisms. Few other chemical systems show this similarity in z-value.

This work is planned to start during 2007 as part of a Development LINK project that has objectives to commercialise a thermostable amylase for food industry use. Both routes for producing the amylase will be studied and a decision taken as to the most promising for industrial use. Proposed work within the Development LINK project will progress the findings in Chapters 5 and 6 by working with larger quantities of starting material. Purification, buffering conditions, heat stability kinetics, improved assay methods, and industrial applications will all feature. At the end of the project the intention is to have a TTI, via one or both of the two approaches, that can be used for measuring industrial sterilisation processes.

Two of the LINK project industrial applications for the sterilisation TTI are to intermittent rotary processing of canned foods with particles and to continuous UHT processing of foods with particles. Data generated will have commercial value in helping provide the data for carrying out process optimisation studies. These are presently limited by the lack of a

measurement system that does not interfere with the measured process. The sterilisation TTI enclosed within a silicone tube will enable this work to be done.

If, and when successful, the sterilisation TTI based on thermostable amylase will find many applications for the measurement of F-values in complex heating situations.

CHAPTER 7: OVERALL CONCLUSIONS

This thesis describes the research and development of a range of time-temperature integrators (TTIs) that are used to measure process values for thermally processed foods. Process values are either for pasteurisation heat treatments (generally $< 100^{\circ}\text{C}$) or sterilisation (> 3 minutes at 121.1°C). All of the TTIs described in this thesis are based on the first order thermal degradation of the protein α -amylase.

Several types of TTIs are described for measuring process values. Two of these TTIs are new developments:

- A TTI for measuring mild pasteurisation treatments of the order of only a few minutes at 70°C . These mild pasteurisation treatments are commonly used for chilled foods with shelf lives less than 10-days. Many of the mild pasteurisation treatments take place in heated vessels or continuous ovens in which the movement of the food product prevents the use of temperature sensors. Examples are given in Chapter 3 in which this new TTI enables these processes to be (i) quantified and (ii) optimised.
- For sterilisation processes, the challenges are much greater because of the limited number of enzyme systems designed to operate above 100°C and at pressures greater than 1 bar. A candidate TTI material is identified based on an amylase secreted by a hyperthermophilic microorganism. This organism, *Pyrococcus furiosus*, exists in extreme conditions where it has evolved in boiling volcanic pools; with elemental sulphur readily available, in water of high salinity, and in a reducing atmosphere. The amylase it secretes is naturally thermostable and is found to withstand a full thermal sterilisation time-temperature process. Data in Chapter 5 shows the potential of this solution as a sterilisation TTI.

Examples are given for how the TTIs are applied to a variety of industrial thermal food processes. These include traditional methods such as canning, and also more complex systems such as tubular heat exchangers and batch vessels, together with novel systems such as ohmic

heating. Process values are calculated using the difference in amylase activity before and after processing. Some of the industrial experiments measure process values in which the thermal effects had not been quantified previously. Considerable over-processing is typical in these situations and so the application of TTIs to these food processes results in improvements in the line efficiency and on occasion in food quality.

Preparation of an amylase TTI for an industrial trial requires the amylase to be protected from contact with the food. Encapsulating the amylase solution in a silicone tube is found to be the most convenient method, which results in a strong yet flexible cylinder containing the amylase TTI solution. Many of the industrial processes where TTIs are used to gather P-value data require the TTIs to be used directly in the form of tubes. These are glued to container surfaces or inserted directly into solid food pieces. One further advantage of using a tube is that it can be easily moulded into silicone food particles whose size is calculated so that the food and TTI particles heat at similar rates. Equations are derived from work in the canning industry that enables the particle sizes to be calculated. Choice of a silicone compound (Sylgard 184 or 170) with similar thermal and physical properties to high water content foods allows the food and TTI particles to behave in a similar manner to food pieces. This overcomes concerns with differences in the way that food and TTI particles move in a food carrying liquid, or in different rates of heat transfer from carrying liquids to particle surfaces.

Chapter 3 describes the BAA70 TTI for mild pasteurisation processes, which is amylase from *Bacillus amyloliquefaciens* at a low concentration of 0.5 mg/mL in acetate buffer. A D_{70} -value of 8.4 minutes and a z-value of 8.9°C are calculated from the kinetic experiments in a water bath. Slightly different values are calculated from silicone oil experiments and this is thought to be caused by water or acetate molecules migrating through the tubing walls. This is an important finding that has implications for handling and storage of other TTI systems. D-value results from the water bath are considered as representative of a medium similar to that in a food product containing a high percentage of water.

The upper limit of P-values that can be measured with the BAA70 TTI depends on the sensitivity of the amylase assay method. It is possible to measure P-values up to 16.8 minutes at 70°C if a colorimeter is used for the assays, and up to 25.2 minutes at 70°C if a spectrophotometer is used. However, most heat treatments for products appropriate for testing with the BAA70 TTI use a minimum process of 70°C for 2 minutes but actually achieve

considerably more than this. Typical processes are often 6-10 minutes at 70°C, which enables the BAA70 TTI to operate within the middle of its range, and therefore at the highest accuracy levels.

Storage of BAA70 TTIs before and after heating tests is a critical operation. Chilled storage for up to 14 days is acceptable but longer storage times enable microbial growth to occur in the acetate buffer. This compromises the amylase behaviour and can affect the kinetics. Storage experiments show that BAA70 TTI tubes are best stored in a freezer to obtain a long shelf life. This is suitable for either unprocessed or processed TTI tubes; it allows frozen TTI tubes to be transported to and from the site of an industrial trial without either (i) the concern of amylase breakdown or (ii) microorganism growth in the buffer solutions. This finding is important for enhancing the merit of TTIs as a method for validating process values in food manufacturing operations.

Results obtained from industry trials demonstrate that the BAA70 TTI is used with great success to evaluate headspace and surface pasteurisation in various containers and food products. BAA70 TTIs can be adopted by food companies for regular QA/QC checks on P-values, for example, BAA70 TTI tubes can be frozen in small numbers, say 5-10 tubes, sufficient for such P-value checks. Analysis of amylase activity can be carried with a colorimeter on site or sent back to a laboratory for a spectrophotometer assay.

Chapter 4 chronicles the development and application of TTIs to measuring P-values in continuous processes or fruit products. Experimental techniques evolved over a series of trials to culminate at the stage in which (i) zero TTI particle damage occurs in the fruit processing equipment and (ii) 100% recovery of TTIs is achieved on most occasions. Encapsulating the amylase solution in 2.5 mm diameter silicone tubes provide a robust system that allows the tubes to be used directly with the food or moulded into larger silicone food particles. Towards the later stages of this research, these silicone particles are made with part black silicone compound to make identification easier.

Many challenges are addressed in Chapter 4 and they are summarised in the following three needs, which are to:

- Introduce TTIs to complex processing systems in a way that represents the distribution of food particles in the preparation step,
- Ensure the TTIs heat and flow in the same way as the critical food particles, without incurring damage to the TTIs,
- Recover all of the TTI particles intact.

Data from TTI trials in Chapter 4 are invaluable for optimising fruit product manufacture at the factory involved in this work. This is demonstrated in a variety of industrial equipment including mixing vessels, a tubular heat exchanger, hot-filling operations, and in an ohmic column. Most fruit processes measured with TTIs show high P-value levels at normal production throughputs; this gives scope for process optimisation to improve production efficiency in some cases improves product quality. The latter is achievable for processes in which the heating takes place with high shearing conditions such as mixing vessels. In general, it is the increases in production efficiency that drives a factory needs for process optimisation.

Despite improvements in TTI recovery from food batches, it is still desirable to develop a fast and reliable method to recover TTI particles from large volumes of food products. Hand sorting is shown to work but takes time and requires the TTI test to be destructive for the food product. Incorporation of a (mildly) radioactive particle into a TTI tube or TTI particle may allow the use of a Geiger counter for their detection. This has not yet been attempted because of concerns about residual radioactivity in food processing environments. Work with the positron emission particle tracking system (PEPT) at the University of Birmingham uses micron sized glass particles with low levels of radioactivity. These may be suitable and provide an alternative TTI particle recovery method.

The search for a TTI suitable for measuring sterilisation processes is a challenge that has eluded the industry so far. Chapter 5 describes the novel concept of an amylase produced by a microorganism of extreme heat stability. Such microorganisms exist in volcanic areas where their environment is comprised of hot water pools rich in sulphur and other elements that are poisonous to most life forms. Some of these, referred to as hyperthermophilic microorganisms, can produce highly active amylase in order to break down the meagre supply

of carbohydrates present in their food sources. Extracellular amylase from *Pyrococcus furiosus* exhibits suitable thermal stability kinetics, which includes both (i) a decimal reduction time high enough for residual amylase activity to be measured following a full sterilisation process, and (ii) a z-value close to 10°C that is the industry standard for *Clostridium botulinum* spores.

During testing of the sterilisation TTI, there were limitations on the numbers of tests that could be done because of low sample mass. This focuses the types of tests and limits the replicates, but despite this, sufficient testing is done to prove that an amylase from *Pyrococcus furiosus* displays suitable thermal behaviour for use as a sterilisation TTI. Isothermal kinetic data are taken to determine the D-value at 121°C although it is non-isothermal methods that are extensively here because they are more efficient in their use of the *Pyrococcus furiosus* amylase. Non-isothermal calibration involves attaching sufficient numbers of TTIs to temperature sensors so that F(t-T) and F(TTI) are calculated for paired values. Experiments using ten to fifteen paired values over the 3 to 15 F₀ range provides sufficient data to obtain D- and z-values.

D-values at 121°C of 18-24 minutes are calculated for isothermal calibrations and 24.5-25.0 minutes for non-isothermal calibrations. A z-value is not done using isothermal method because of limitations with the mass of FDP available. These tests require at least four D-values, so instead, non-isothermal calibration is used for measuring z-value. The z-value from the first set of thermal processes came out at 9.95±1.5°C, which is close to the *Clostridium botulinum* value of 10°C.

F-values measured with the sterilisation TTIs are within 1.5 F-value units of the probe F-values over most of the measurement range. The exception is for an F₀-value of 28 minutes where the TTI system gives a lower value; this is thought to be outside of the upper measurement range for the TTI. Obtaining high accuracy at high F₀-values is less important than with process safety where the operating region is in the lower range towards F₀ 3. It may be that the sterilisation TTI can measure up to one-log reduction in amylase activity at the 25 mg/mL FDP concentration tested here.

Results presented in Chapter 5 are the culmination of three years of effort in characterising the sterilisation TTI in solution. Much of this time is involved with obtaining amylase from the

hyperthermophilic microorganism *Pyrococcus furiosus*. Heat stable amylase from *Pyrococcus furiosus* is demonstrated as a suitable material for use as a TTI for thermal sterilisation processes. Due to the small sample sizes available it is not possible to complete all the testing appropriate for a new TTI. Further experimental work is required in a number of areas to address the questions that arose during the research, for example:

- It is necessary to obtain larger quantities of FDP to enable further testing. Conditions used in batch fermentations may not be optimal for amylase production and may result in detrimental by-products (e.g. proteases). Continuous fermentation could be used for greater yields and consistency.
- The best conditions for storing the FDP and of the filled sterilisation TTI tubes need to be determined. This is important to prevent loss in activity during transportation to/from industry trials. It is assumed that storing the TTI tubes in acetate buffer, which are then put into a freezer, is the best method since this is used with other TTI systems.
- The end point for work reported here was FDP with minimal purification. Reduction in activity is measured when the sterilisation TTIs are stored chilled, which is thought to be caused by proteases acting on the amylase. The FDP is not a pure amylase and so other by-products of the fermentation are present, and some may be detrimental to the amylase.
- What variability should be expected for the sterilisation TTI. This TTI has many applications to industrial thermal processes and so it is necessary to understand the accuracy of F-values estimated from the TTIs.
- Long term supply of FDP with reproducible heat stability properties needs to be guaranteed. Fermentation of the native *Pyrococcus furiosus* organism may not be the best method to produce heat stable amylase. There are many reports of the gene being expressed in bacteria such as *E. coli* or in yeast and mould. Reports suggest the amylase from an *E. coli* retains its heat stability but this is not been evaluated in the rigorous way as is required for a sterilisation TTI. Early results are given in Chapter 6 for thermostable amylase produced from a yeast culture where the amylase producing gene is expressed into yeast cells.

Chapter 6 investigates cloning of the amylase producing gene into the common yeast cell *Saccharomyces cerevisiae*. This is a potential route to securing large quantities of thermostable amylase that do not require the extreme fermentation conditions with *Pyrococcus furiosus*. First measurements of amylase heat stability suggest the amylase is at least sufficiently heat stable for measurements of thermal processes of several minutes at 121.1°C. In fact, work is needed to reduce the heat stability; this work is planned to start during 2007 as part of a collaborative project with objectives to commercialise the amylase for food industry use. Both *Pyrococcus furiosus* amylase and the cloned yeast cell will be studied and a decision taken as to the most promising. Purification, buffering conditions, heat stability kinetics, improved assay methods, and industrial applications all need to be addressed. At the end of the project the intention is to have a TTI, via one or both of the two approaches, that can be used for measuring industrial sterilisation processes. If, and when successful, the sterilisation TTI based on thermostable amylase will find many applications for the measurement of F-values in complex heating situations.

In conclusion, TTIs represent one of the most significant advances in techniques for measuring process values for the food industry. All of the TTIs in this thesis are based on the thermal degradation of amylase solutions. There is something unique about the way amylase breaks down with heat that results in kinetics with z-values close to 10°C, which is the value required to mimic microorganism death. Adjustment of the type of amylase, its concentration and the buffering solutions are used to manipulate the amylase heat stability to suit the needs of the process. The two new TTIs developed here, for mild pasteurisation and full sterilisation, complete the required range of TTIs so that all thermal treatments of food products can be measured with a TTI. There is still work required with the sterilisation TTI, however, results are promising and the two routes forward by producing thermostable amylase from either the native or cloned organism give rise to genuine optimism. Engineering developments in TTI construction are demonstrated that enables the TTIs to be applied to industrial food processes. While relatively simple in conception the silicone TTI tubes and particles have wide ranging applications. This is important in ensuring these TTI techniques are used regularly in the food industry.

REFERENCES

Adams, M.W.W., Holden, J.F., Menon, A.L., Schut, G.J., Grunden, A.M., Hou, C., Hutchins, A.M., Jenney, F.E. Jr., Kim, C., Ma, K., Pan, G., Roy, R., Sapra, R., Story, S.V. and Verhagen, M.F.J.M. (2001). Key role for sulfur in peptide metabolism and in regulation of three hydrogenases in the hyperthermophilic archaeon *Pyrococcus furiosus*. *Journal of Bacteriology*. 183, 716-724.

Adams, J.B. (1978). The inactivation and regeneration of peroxidase in relation to the high temperature short time processing of vegetables. *Journal of Food Technology*, 13, 281-197.

Adams, J.B. (1996). Determination of $D_{80^{\circ}\text{C}}$ for α -amylase inactivation. CCFRA Internal Project Report, Ref: 12598/1, May 1996. Campden & Chorleywood Food Research Association.

Adams, J.B. and Langley, F.M. (1998). Nitrophenyl glucoside hydrolysis as a potential time-temperature integrator reaction. *Food Chemistry*, 62 (1), 65-68.

Adams, J.A. and Rogers, D.F. (1973). *Computer Aided Analysis in Heat Transfer*. McGraw-Hill Education.

American Heritage Dictionary (2003). *American Heritage Dictionary of the English Language*, Fourth Edition copyright 2000 by Houghton Mifflin Company. Updated in 2003. Published by Houghton Mifflin Company.

Bakalis, S. (2005). New Trends – Old themes in food engineering. Presentation at IChemE Food and Drink subject group meeting, November 2005, Unilever Colworth.

Ball, C.O. (1923). Thermal Process Time for Canned Food, *Bulletin of the National Research Council*, Washington, DC. Vol. 7, Part 1, Number 37.

Ball, C.O. (1927). Theory and practice in processing. *The Canner*, 64 (5):27.

Ball, C.O. and Olsen, F.C.W. (1957). *Sterilization in Food Technology*. McGraw-Hill Book Co., New York.

Bee, G.R. and Park, D.K. (1978). Heat penetration measurement for thermal process design. *Food Technology*, 32 (6), 56-58.

Barbier, G., Godfroy, A., Meunier, J.R., Querellou, J., Cambon, M.A., Lesongeur, F., Grimont, P.A.D. and Raguenes, G. (1999). *Pyrococcus glycovorans* sp. nov., a hyperthermophilic archaeon isolated from the East Pacific Rise. *International Journal of Systematic Bacteriology*, 49, 1829-1837.

Bauman, H.E. (1974). The HACCP concept and microbiological hazard categories. *Food Technology*, 28 (9), 30-2, 74.

Bergmeyer, H.U. and Grassl, M. (1983). Reagents for enzymatic analysis enzymes – α -amylase. In: *Methods of enzymatic analysis*, 3rd edition, Vol. 2, Bergmeyer, H.U. (editor), Verlag Chemie, Weinheim, pp.151-152.

Bernfeld, P. (1955). Amylases α and β . *Methods of Enzymology*, 1, 149-158.

Bigelow, W.D., Bohart, G.S., Richardson, A.C and Ball, C.O. (1920). Heat penetration in processing canned foods. *National Canners Association Bulletin* 161.

Blamey, J.M. and Adams, M.W. (1994). Characterization of an ancestral type of pyruvate ferredoxin oxidoreductase from the hyperthermophilic bacterium, *Thermotoga maritima*. *Biochemistry*, 33, 1000-1007.

Blamey, J., Chiong, M., Lopez, C. and Smith, E. (1999), Optimization of the growth conditions of the extremely thermophilic microorganisms *Thermococcus celer* and *Pyrococcus woesei*. *Journal of Microbiological Methods*, 38, 169-75.

Brown, S.H., Costantino, H.R. and Kelly, R.M. (1990). Characterization of amylolytic enzyme activities associated with the hyperthermophilic archaeobacterium *Pyrococcus furiosus*. *Applied and Environmental Microbiology*. 56 (7), 1985-1991.

Brown, K.L., Ayres, C.A., Gaze, J.E. & Newman, M.E. (1984). Thermal destruction of bacterial spores immobilised in food/alginate particles. *Food Microbiology*, 1, 187-198.

CCFRA (1977). Guidelines to the establishment of scheduled heat processes for low-acid foods, CCFRA Technical Manual No.3, Campden & Chorleywood Food Research Association.

CCFRA (1986). Guidelines for the processing and aseptic packaging of low-acid foods. CCFRA Technical Manual No.11, Campden & Chorleywood Food Research Association.

CCFRA. (1992a). Food Pasteurisation Treatments. Technical Manual No.27, Edited by Joy Gaze. Campden & Chorleywood Food Research Association.

CCFRA. (1992b). The microbiological safety of sous-vide processing. Technical Manual No.39, Edited by Gail Betts. Campden & Chorleywood Food Research Association.

CCFRA (2006a). New Technologies Bulletin No. 32. Update on ohmic heating. 32, 3-20.

CCFRA. (2006b). Pasteurisation: A food industry practical guide (second edition). Guideline No.51. Edited by Joy Gaze. Campden & Chorleywood Food Research Association.

CCFRA (2007). Guidelines for the processing and aseptic packaging of. CCFRA Guideline 53, Campden & Chorleywood Food Research Association.

Day, B.P.F. (2001). Fresh prepared produce: GMP for high oxygen MAP and non-sulphite dipping. Guideline No.31, Campden & Chorleywood Food Research Association.

De Alwis, A.A.P. & Fryer, P.J. (1990a). A finite element analysis of heat generation and transfer during ohmic heating of foods. *Chemical Engineering Science*, 45, 1547-1559.

De Alwis, A.A.P. & Fryer, P.J. (1990b). The use of direct resistance heating in the food industry. *Journal of Food Engineering*, 11, 3-27.

De Cordt, S., Hendrickx, M., Maesmans, G., and Tobback, P. (1992). Immobilised α -amylase from *Bacillus licheniformis*: a potential enzymic time-temperature integrator for thermal processing. *International Journal of Food Science and Technology*, 27, 661-673.

De Cordt, S., Avila, I., Hendrickx, M. & Tobback, P. (1994). DSC and protein-based time-temperature integrators: Case study of α -amylase stabilised by polyols and/or sugar. *Biotechnology & Bioengineering*, 44, 859-865.

DoH (1989). Chilled and frozen guidelines on cook-chill and cook-freeze catering systems. HMSO.

DoH (1994). Guidelines for the safe production of heat preserved foods. London: The Stationery Office. ISBN 0 11 321801X.

Dong, G., Vieille, C. and Zeikus, J.G. (1997). Cloning, sequencing, and expression of the gene encoding amylopullulanase from *Pyrococcus furiosus* and biochemical characterization of the recombinant enzyme. *Applied and Environmental Microbiology*, 63, 3577-3584.

Dorland (2007). Dorland's Medical Dictionary for Health Consumers 2007. On-line version. Published by Saunders, an imprint of Elsevier, Inc.

Dow Corning (1986). Information about High Technology Materials Sylgard 182 & 184 Silicone Elastomers. Data Sheet number 61-113C-01, June 1986. Dow Corning Europe, Chaussee de la Hulpe 154, B-1170 Brussels, Belgium.

Dow Corning (1998). Information sheets on Sylgard 170 A & B silicone elastomer. Data Sheet number 61-045E-01, July 1998. Dow Corning Europe, Chaussee de la Hulpe 154, B-1170 Brussels, Belgium.

Driskill, L.E., Kusy, K., Bauer, M.W. and Kelly, R.M. (1999). Relationship between glycosyl hydrolase inventory and growth physiology of the hyperthermophile *Pyrococcus furiosus* on carbohydrate-based media. *Applied and Environmental Microbiology*, 65, 893-897.

Esty, J.R. and Meyer, K.F. (1922). The heat resistance of the spores of *B. Botulinus* and allied anaerobes. XI. J. Infectious Diseases, 31, 650-663.

Fiala, G. and Stetter, K.O. (1986). *Pyrococcus furiosus* sp. Nov. represents a novel genus of marine heterotrophic archaeobacteria growing optimally at 100°C. Archives of Microbiology, 145, 56-61.

Fourier, J. (1822). Théorie analytique de la chaleur, Firmin Didot, Paris.

Fryer, P.J. (1995). Electrical resistance heating of foods. In Gould, G.W. (Ed). New Methods of Food Preservation, Blackie Academic & Professional, London.

Frillingos, S., Linden, A., Niehaus, F., Vargas, C., Nieto, J.J., Ventosa, A., Antranikian, G. and Drinas, C. (2000). Cloning and expression of α -amylase from the hyperthermophilic archaeon *Pyrococcus woesei* in the moderately halophilic bacterium *Halomonas elongata*. Journal of Applied Microbiology, 88, 495-503.

George, R.M. (1990). A literature survey of the thermal diffusivity of food products. Technical Bulletin No. 73, Campden & Chorleywood Food Research Association.

Gillespy, T.G. (1951). Estimation of sterilising values of processes as applied to canned foods. I. Packs heating by conduction. Journal of the Science of Food and Agriculture, 2, 107-125.

Guiavarc'h, Y., Dintwa, E., Van Loey, A., Zuber, F. and Hendrickx, M. (2002a). Validation and use of an enzymic time-temperature integrator to monitor thermal impacts inside a solid/liquid model food. Biotechnology Progress, 18, 1087-1094.

Guiavarc'h, Y., Deli, V., Van Loey, A., Zuber, F. and Hendrickx, M. (2002b). Development of an enzymic time temperature integrator for sterilization processes based on *Bacillus licheniformis* alpha-amylase at reduced water content. Journal of Food Science, 67, 285-291.

Guiavarc'h, Y. (2003). Development and use of enzymic time-temperature integrators for the assessment of thermal processes in terms of food safety. PhD Thesis No.570, Katholieke Universiteit Leuven, Belgium.

Guiavarc'h, Y., Sila, D., Duvetter, T., Van Loey, A. and Hendrickx, M. (2003). Influence of sugars and polyols on the thermal stability of purified tomato and cucumber pectinmethylesterases: a basis for TTI development. *Enzyme and Microbial Technology*, 2003, 33, 544-555.

Guiavarc'h, Y., Van Loey, A., Zuber, F. and Hendrickx, M. (2004a). Development characterization and use of a high-performance enzymatic time-temperature integrator for the control of sterilization process' impacts. *Biotechnology and Bioengineering*, 88, 15-25.

Guiavarc'h, Y., Van Loey, A., Zuber, F. and Hendrickx, M. (2004b). *Bacillus licheniformis* alpha-amylase immobilized on glass beads and equilibrated at low moisture content: potentials as a time-temperature integrator for sterilisation processes. *Innovative-Food Science and Emerging Technologies*, 5, 317-325.

Hendrickx, M., Saraiva, J., Lyssens, J., Oliveira, J. & Tobback, P. (1992). The influence of water activity on thermal stability of horseradish peroxidase. *International Journal of Food Science & Technology*, 27, 33-40.

Hendrickx, M., Maesmans, G., De Cordt, S., Noronha, J., Van Loey, A. & Tobback, P. (1995). Evaluation of the integrated time-temperature effect in thermal processing of foods. *Critical Reviews in Food Science & Nutrition*, 35 (3), 231-262.

Heppell, N.J. (1985). Measurement of the liquid-solid heat transfer coefficient during continuous sterilisation of liquids containing particles. In: *Proceedings of IUFOST Symposium, Aseptic Processing and Packaging of Foods*, Tylosand, Sweden. p.108.

Holdsworth, S.D. (1992). *Aseptic processing and packaging of food products*. Elsevier Science Publishers Ltd. ISBN 1-85166-775-X.

Holdsworth, S.D. (1997). Thermal processing of packaged foods. Blackie Academic & Professional, London.

Hutton, T.C. (2004). Food preservation: an introduction. Key Topics in Food Science and Technology, No.9. Campden & Chorleywood Food Research Association.

IFTPS (1995). Institute for Thermal Processing Specialists. Protocol for conducting heat penetration studies. www.iftps.org.

IFTPS (1997). Institute for Thermal Processing Specialists. Nomenclature for studies in thermal processing. www.iftps.org.

Jorgensen, S., Vorgias, C.E. and Antranikian, G. (1997). Cloning, sequencing, characterization, and expression of an extracellular alpha-amylase from the hyperthermophilic archaeon *Pyrococcus furiosus* in *Escherichia coli* and *Bacillus subtilis*. Journal-of-Biological-Chemistry. 1997; 272(26): 16335-16342.

Kim, H-J., Choi, Y-M., Yang, A.P.P., Yang, T.C.S., Taub, I.A., Giles, J., Ditusa, C., Chall, S., and Zoltai, P. (1996a). Microbiological and chemical investigation of ohmic heating of particle foods using a 5 kW ohmic system. Journal of Food Preservation and Processing, 20, 41-58.

Kim, H-J., Choi, Y-M., Yang, T., Taub, I.A., Tempest, P., Skudder, P., Tucker, G. and Parrott, D.L. (1996b). Validation of ohmic heating for quality enhancement of food products. Food Technology, 50 (5), 253-261.

Koch, R., Zabłowski, A., Spreinat, A. and Antranikian, G. (1990). Extremely thermostable amylolytic enzyme from the archaebacterium *Pyrococcus furiosus*. FEMS Microbiology Letters. 71, 21-26.

Koch, R., Spreinat, A., Lemke, K and Antranikian, G. (1991). Purification and properties of a hyperthermoactive α -amylase from the archaebacterium *Pyrococcus woesei*. Archives Microbiology. 155, 572-578.

Krieth, F. and Bihn, M.S. (1986). Principles of heat transfer. Harper and Row, New York. ISBN: 0-06-043785-5.

Laderman, K.A., Davis, B.R., Krutzsch, H.C., Lewis, M.S., Griko, Y.V., Privalov, P.L. and Anfinsen, C.B. (1993). The purification and characterization of an extremely thermostable α -amylase from the hypertherophilic archaeobacterium *Pyrococcus furiosus*. The Journal of Biological Chemistry, 32, 24394-24401.

Lambourne, T. and Tucker, G.S. (2001). Time temperature integrators for validation of thermal processes. R&D Report No.132. CCFRA, Chipping Campden, Glos., GL55 6LD.

Leuschner, C. and Antranikian, G. (1995). Heat-stable enzymes from extremely thermophilic and hyperthermophilic microorganisms. World Journal of Microbiology and Biotechnology, 11, 95-114.

Lioliou, E.E., Pantazaki, A.A. and Kyriakidis, D.A. (2004). *Thermus thermophilus* genome analysis: benefits and implications. Microbial Cell Factories, 3, 5-.

Maesmans, G., Hendrickx, M., De Cordt, S., Van Loey, A., Noronha, J., & Tobback, P. (1994). Evaluation of process value distribution with time temperature integrators. Food Research International, 27, 413-423.

Manning, G.B. and Campbell, L.L. (1961). Thermostable α -Amylase of *Bacillus stearothermophilus*. I. Crystallization and some general properties. Journal of Biological Chemistry, 236, 2952-2957.

McKenna, A.B. and Tucker, G.S. (1991). Computer modelling for the control of particle sterilization under dynamic flow conditions. Food Control, 2, 224-233.

Mehauden, K. (2006). Verification of the reliability of the Time Temperature Integrators made from the α -amylase of the *Bacillus amyloliquefaciens* for assuring the safety of various thermal processes. Presentation at 8th TTI LINK project meeting, held at Baxters of Speyside Ltd, 6 September 2006.

Mehauden, K., Cox, P.W., Bakalis, S., Fryer, P.J. (2006). Validation of thermal processing of foods in large agitated vessels. Poster paper at IUFoST conference, 17-21 September 2006, Nantes, France.

Mehauden, K., Cox, P.W., Bakalis, S., Simmons, M.J.H., Tucker, G.S. and Fryer, P.J. (2007). A novel method to evaluate the applicability of time-temperature integrators to different temperature profiles. *Innovative Food Science & Emerging Technologies*, 8, 507-514.

Mehauden, K. (2007). Heating efficiency of the Giusti vessel (Vesuvio). Presentation at the 9th AFM194 TTI LINK Project Meeting, 31 January 2007, CCFRA.

Melasniemi, H. (1987). Characterization of alpha-amylase and pullulanase activities of *Clostridium thermohydrosulfuricum*. Evidence for a novel thermostable amylase. *The Biochemical Journal*, 246, 193-197.

Melasniemi, H. (1988). Purification and some properties of the extracellular alpha-amylase-pullulanase produced by *Clostridium thermohydrosulfuricum*. *The Biochemical Journal*, 250, 813-818.

Melasniemi, H. and Paloheimo, M. (1989). Cloning and expression of the *Clostridium thermohydrosulfuricum* alpha-amylase-pullulanase gene in *Escherichia coli*. *Journal of General Microbiology*, 135, 1755-1762.

Miles, J.J. and Swartzel, K.R. (1995). Evaluation of continuous thermal processes using thermocouple data and calibrating reactions. *Journal of Food Process Engineering*, 18, 99-113.

Montville, T.J. (1982). Metabolic effect of *Bacillus licheniformis* on *Clostridium botulinum*: implications for home-canned tomatoes. *Applied and Environmental Microbiology*, 44, 334-338.

Niehaus, F., Bertoldo, C., Kahler, M. and Antranikian, G. (1999). Extremophiles as a source of novel enzymes for industrial application. *Applied Microbiology and Biotechnology*, 51, 711-29.

Pape, G. (2006). Container specifications: The influence of sterilisation systems. Presentation at: 4th International Conference on Thermal Processing: Innovations for Quality Improvement. CCFRA, 8-9 June 2006.

Perevalova, A.A., Svetlichny, V.A., Kublanov, I.V., Chernyh, N.A., Kostrikina, N.A., Tourova, T.P., Kuznetsov B.B. and Bonch-Osmolovskaya, E.A. (2005). *Desulfurococcus fermentans* sp. nov., a novel hyperthermophilic archaeon from a Kamchatka hot spring, and emended description of the genus *Desulfurococcus*. *International Journal of Systematic Evolutionary Microbiology*, 55, 995-999.

Pickles, J. (2006). Canned soup: the problem with innovation. Presentation at: 4th International Conference on Thermal Processing: Innovations for Quality Improvement. CCFRA, 8-9 June 2006.

Put, H.M.C. and de Jong, J. (1982). The heat resistance of ascospores of four *Saccharomyces* species isolated from spoiled heat-processed soft drinks and fruit products. *Journal of Applied Bacteriology*, 52, 235-243.

Reyes de Corcuera, J.I., Cavalieri, R.P., Powers, J.R., Tang, J. and Kang, D.H. (2005). Enzyme-electropolymer-based amperometric biosensors: an innovative platform for time-temperature integrators. *Journal of Agricultural and Food Chemistry*, 53, 8866-8873.

Ruan, R., Ye, X., Chen, P. (2004) Developments in ohmic heating. In: Improving the thermal processing of foods. Richardson P. (Eds) Woodhead Publishing Ltd. Cambridge UK.

Samborska, K., Guiavarc'h, Y., Van Loey, A., Hendrickx, M. (2005). The influence of moisture content on the thermostability of *Aspergillus oryzae* alpha-amylase. *Enzyme and Microbial Technology*, 37, 167-174.

Sastry, S.K. and Salengke, S. (1998). Ohmic heating of solid-liquid mixtures: a comparison of mathematical models under worst-case heating conditions. *Journal of Food Process Engineering*, 21, 441-458.

- Savchenko, A., Vieille, C., Kang, S. and Zeikus, J.G. (2002). Pyrococcus furiosus alpha-amylase is stabilized by calcium and zinc. *Biochemistry*, 41, 6193-6201.
- Schaffers, I. (2007). Thermostable Amylase. Presentation to 9th AFM194 Project Consortium. Held at CCFRA on 31st January 2007.
- Schut, G.J., Brehm, S.D., Datta, S. and Adams, M.W.W. (2003). Whole-genome DNA microarray analysis of a hyperthermophile and an archaeon: *Pyrococcus furiosus* grown on carbohydrates or peptides. *Journal of Bacteriology*. 185, 3935-3947.
- Seegerer, A.H, Burggraf, S., Fiala, G., Huber, G., Huber, R., Pley, U. and Stetter, K.O. (1993). Life in hot springs and hydrothermal vents. *Origins of Life and Evolution of the Biosphere: the Journal of the International Society for the Study of the Origin of Life*, 23 (1), 77-90.
- Skudder, P.J. (1988). Ohmic heating: new alternative for aseptic processing viscous foods. *Journal of Food Engineering*, 60(1): 99-101.
- Soil Association (2005). Flavr Savr tomato & GM tomato puree: The failure of the first GM foods. Soil Association Briefing Paper 29/11/2005.
- Sternier, R. and Liebl, W. (2001). Thermophilic adaptation of proteins. *Critical Reviews in Biochemistry and Molecular Biology*, 36 (1), 39-106.
- Stetter, K.O. (1996). Hyperthermophiles in the history of life. *Ciba Foundation Symposium*, 202: 1-10, discussion 11-18.
- Stumbo, C.R. (1949). Further considerations relating to the evaluation of thermal processes for foods. *Food Technology*, 3, 126.
- Stumbo, C.R. (1965). *Thermobacteriology in food processing*. Academic Press, 111 Fifth Avenue, New York.
- Tachibana, Y., Fujiwara, S., Takagi, M. and Imanaka, T. (1997). Cloning and expression of the 4-alpha-glucanotransferase gene from the hyperthermophilic archaeon *Pyrococcus* sp.

KOD1, and characterization of the enzyme. *Journal of Fermentation and Bioengineering*, 83, 540-548.

Tomazic, S.J. and Klibanov, A.M. (1988). Mechanisms of irreversible thermal inactivation of *Bacillus* α -amylases. *The Journal of Biological Chemistry*, 263 (7), 3086-3091.

Townsend, C.T., Esty, J.R. and Baselt, F.C. (1938). Heat resistance studies on spores of putrefactive anaerobes in relation to determination of safe processes for canned foods. *Food Research*, 3, 323-346.

Tucker, G.S and Holdsworth, D. (1991). Mathematical modelling of sterilisation and cooking processes for heat preserved foods. Application of a new heat transfer model. *Transactions of the Institution of Chemical Engineers, Food & Bioproducts Processing*, 69, Part C, 5-12.

Tucker, G.S. and Withers, P.W. (1994). Determination of residence time distribution of nonsettling food particles in viscous food carrier fluids using hall effects sensors. *Journal of Food Process Engineering*, 17, 401-422.

Tucker, G.S., Noronha, J.F. and Heydon, C.J. (1996). Experimental validation of mathematical procedures for the valuation of thermal processes and process deviations during the sterilization of canned foods. *Transactions of the Institution of Chemical Engineers, Food & Bioproducts Processing*, 74, Part C, 140-148.

Tucker, G.S. (1998a). Comment calculer les valeurs de pasteurisation dans le produits avec morceaux avec l'integrateur temps-temperature amylase. Presentation at: Symposium Technique International de l'appertise UPPIA/CTCPA "Securite et appertisation: de nouveaux outils pour la maitrise des treatments thermiques", 28 April 1998, Paris.

Tucker, G.S. (1999). A novel validation method: Application of time-temperature integrators to food pasteurization treatments. *Transactions of the IChemE, Food and Bioproducts Processing*, 77, Part C, 223-231.

Tucker, G.S. (1999a). Heating and cooling of solid-liquid foods in heat exchangers. R&D Report No.87. Campden & Chorleywood Food Research Association.

Tucker, G.S. (1999b). Application of biochemical time-temperature integrators to food pasteurisation treatments. Presentation at the 8th International Congress on Engineering and Food. Puebla, Mexico, 9-12 April, 2000.

Tucker, G.S. (1999c). Application of time-temperature integrators for validation of pasteurisation processes. R&D Report No.77. CCFRA, Chipping Campden, Glos., GL55 6LD.

Tucker, G.S. (2000). Estimation of pasteurisation values using an enzymic time-temperature integrator. *Food Australia*, 52 (4), 131-136.

Tucker, G.S., Lambourne, T., Adams, J.B. and Lach, A. (2002). Application of biochemical time-temperature integrators to estimate pasteurisation values in continuous food processes. *Innovative Food Science & Emerging Technologies*, 3, 165-174.

Tucker, G. (2003). Time-temperature Integrators As A Novel Sensor For Thermal Processes Safety. IChem^E Food & Drink Subject Group. Newsletter Issue 02.

Tucker, G.S. and Wolf, D. (2003). Time-temperature integrators for food process analysis, modelling and control. R&D Report No.177. Campden & Chorleywood Food Research Association.

Tucker, G.S. (2004). Using the process to add value to heat-treated products. *Journal of Food Science*. 69 (3), 102-104.

Tucker, G.S., Wolf, D. and Lach, A. (2004). Time-temperature integrators applied to pasteurised high acid foods processed with ohmic heating. ICEF9 – International Congress on Engineering and Food. p.4-

Tucker, G., Cronje, M. and Lloyd, E. (2005). Evaluation of a time-temperature integrator for mild pasteurisation processes. R&D Report No.215. CCFRA, Chipping Campden, Glos., GL55 6LD.

Tucker, G.S., Brown, H.M., Fryer, P.J., Cox, P.W., Poole II, F.L., Lee H.-S. and Adams, M.W.W. (2007). A sterilisation time-temperature integrator based on amylase from the hyperthermophilic organism *pyrococcus furiosus*. *Innovative Food Science and Emerging Technologies*, 8, 63-72.

Uma Maheswar Rao, J.L. and Satyanarayana, T. (2004). Amelioration in secretion of hyperthermostable and Ca²⁺-independent α -amylase of *Geobacillus thermoleovorans* by some polyamines and their biosynthesis inhibitor methylglyoxal-bis-guanylhydrazone. *Journal of Applied Microbiology*, 97, 1015-.

U.S. Food and Drug Administration. (2000). *Kinetics of Microbial Inactivation for Alternative Food Processing Technologies*.

Vaidya, S., Orta-Ramirez, A., Smith, D.M. and Ofoli, R.Y. (2003). Effect of heat on phycoerythrin fluorescence: influence of thermal exposure on the fluorescence emission of R-phycoerythrin. *Biotechnology and Bioengineering*, 83, 465-473.

Vasavada, A. (1995). Improving productivity of heterologous proteins in recombinant *S. cerevisiae* fermentations. *Advances in Applied Microbiology*, 41, 25-54.

Van Loey, A.M., Hendrickx, M. E., De Cordt, S., Haentjens, T.H. & Tobback, P. P. (1996). Quantitative evaluation of thermal processes using time-temperature integrators. *Trends in Food Science & Technology*, 7, 16-26.

Van Loey, A.M., Arthawan, A., Hendrickx, M. E., Haentjens, T.H., & Tobback, P. P. (1997a). The development and use of an α -amylase based time-temperature integrator to evaluate in-pack pasteurisation processes. *Lebensmittel-Wissenschaft und-Technologie*, 30, 94-100.

Van Loey, A.M., Haentjens, T.H., Hendrickx, M. E. and Tobback, P. P. (1997b). The development of an enzymic time temperature integrator to assess the thermal efficacy of sterilization of low-acid canned foods. *Food Biotechnology*, 11 (2), 147-168.

- Verhagen, M.F.J.M., Menon, A.L., Schut, G.J. and Adams, M.W.W. (2001). *Pyrococcus furiosus*: Large-scale cultivation and enzyme purification. *Methods in Enzymology*, 330, 25-30.
- Verrips, T., Duboc, P., Visser, C. and Sagt, C. (2000). From gene to product in yeast: production of fungal cutinase. *Enzyme and Microbial Technology*, 26, 812-818.
- Vieille, C and Zeikus, G. (2001). Hyperthermophilic enzymes: Sources, uses and molecular mechanisms for thermostability. *Microbiology and Molecular Biology Reviews*, 65 (1), 1-43.
- Wei, S. Zhengxiang, W., Jiquan, L. and Jian, Z. (2003). Expression of a hyperthermophilic alpha-amylase of the archaeon *Pyrococcus furiosus* in *Escherichia coli*. *Food & Fermentation Industries*, 29, 10-14.
- Weinberg, M.V., Schut, G.J., Brehm, S., Datta, S. and Adams, M.W.W. (2005). Cold Shock of a Hyperthermophilic Archaeon: *Pyrococcus furiosus* Exhibits Multiple Responses to a Suboptimal Growth Temperature with a Key Role for Membrane-Bound Glycoproteins. *Journal of Bacteriology*, 187, 336-348.
- Wikipedia (2006). Wikipedia – A Free Encyclopedia. Wikipedia Foundation, Inc. http://en.wikipedia.org/wiki/Gene_expression.
- Wong, H.Y. (1977). Heat transfer for engineers. Longman Group Ltd, London.
- Worthington, P., Hoang, P., Perez-Pomares, F. and Blum, P. (2003). Targeted Disruption of the α -Amylase Gene in the Hyperthermophilic Archaeon *Sulfolobus solfataricus*. *Journal of Bacteriology*, 185, 482-488.
- Yang, S-J., Lee, H-S., Park, C-S., Kim, Y-R., Moon, T-W. and Park, K-H. (2004). Enzymatic Analysis of an Amylolytic Enzyme from the Hyperthermophilic Archaeon *Pyrococcus furiosus* Reveals Its Novel Catalytic Properties as both an α -Amylase and a Cyclodextrin-Hydrolyzing Enzyme. *Applied and Environmental Microbiology*, 70, 5988-5995.

Zeikus, J.G., Vieille, C. and Savchenko, A. (1998). Thermozyms: biotechnology and structure-function relationships. *Extremophiles*, 2, 179-83.

Zhang, L. and Fryer, P. J. (1993) Models for the electrical heating of solid-liquid mixtures. *Chemical Engineering Science*, 48, 633-643.

APPENDIX 1:

Preparation Of *Pyrococcus Furiosus* Broths Supplied By University Of Georgia

The fermentation medium contained seven separate components (a-g) prepared as separate sterile stock solutions and stored at 4°C. Stock solutions were as follows:

- a) 5 × salts solution, containing, per litre, 140 g of NaCl, 17.5 g of MgSO₄ · 7H₂O, 13.5 g of MgCl₂ · 6H₂O, 1.65 g of KCl, 1.25 g of NH₄Cl, and 0.70 g of CaCl₂ · 2H₂O
- b) 100 mM Na₂WO₄ · 2H₂O (10,000 ×, containing 33.0 g of Na₂WO₄ · 2H₂O per litre)
- c) 1,000 × trace minerals solution, containing, per litre, 1 mL of HCl (concentrated), 0.5 g of Na₄EDTA, 2.0 g of FeCl₃, 0.05 g of H₃BO₃, 0.05 g of ZnCl₂, 0.03 g of CuCl₂ · 2H₂O, 0.05 g of MnCl₂ · 4H₂O, 0.05 g of (NH₄)₂MoO₄, 0.05 g of AlK(SO₄) · 2H₂O, 0.05 g of CoCl₂ · 6H₂O, and 0.05 g of NiCl₂ · 6H₂O
- d) potassium phosphate buffer, pH 6.8 (1,000 ×), containing 450 mL of 1 M KH₂PO₄ (pH 4.3), to which 1 M K₂HPO₄ was added until the solution reached pH 6.8 (approximately 550 mL)
- e) 10% (wt/vol) yeast extract, consisting of 100 g of filter-sterilized yeast extract (DIFCO) per litre
- f) 10% (wt/vol) casein hydrolysate, consisting of 100 g of filter-sterilized casein hydrolysate (enzymatic; U.S. Biochemicals) per litre, 50% (wt/vol) maltose, or 5% (wt/vol) starch
- g) 50 g resazurin at 5 mg per mL.

The 5 x salts solution and maltose were filter sterilised. All other solutions were degassed and flushed with argon and stored at 4°C. The reducing reagent consisted of cysteine, HCl (0.5 g), Na₂S (0.5 g) and NaHCO₃ (1.0 g) per 500 mL adjusted to pH 6.8 with 1M HCl. The solution was filter sterilised before use.

University of Georgia supplied broth from three 1-litre cultures of *P. furiosus* so that they could be compared for amylase activity and relative heat stability. Each broth used a different source of carbon; these were peptides, maltose or starch. The peptides/S medium contained 0.5% wt/vol casein hydrolysate (enzymatic), while the maltose and starch media both contained 1% w/vol of the indicated carbohydrates. Sulphur was added directly as a suspension to give a final concentration of 5 mg/mL.

Three 1-Litre Cultures

For growth of the 1-litre cultures, a fresh overnight culture of *P. furiosus* was used to inoculate (2% vol/vol) a 40 mL culture which was then grown overnight at 98°C without stirring. Each 40 mL culture was then used as an inoculum for one 500 mL culture contained in a one-litre flask. Each 1-litre was grown for 12 h at 98°C to a cell density of $\sim 2 \times 10^8$ cells/mL. Two 500-mL cultures were used for each of the three conditions (peptides, maltose and starch) to give a total of one-litre culture for each. The extracellular fraction was collected by centrifugation at 10,000 x g for 10 minutes at 4°C. The supernatant was pink in colour because of resazurin (see Figure 1).

Samples (2 mL) of the 1-litre cultures were saved before and after removing the cells for activity assays. To each 1-litre of supernatant, a total of 561 g of ammonium sulphate was added slowly over a 1 h period with stirring, and the solution was allowed to stir for a further 16 h at 4°C. The precipitated material was collected by centrifugation at 10,000 x g for 10 minutes. After decanting the supernatant, the precipitate was sent by express mail to Campden & Chorleywood Food Research Association Group Services packed in dry ice. Figure 1 shows the bottles as received at CCFRA.



Figure 1: Protein precipitates received at CCFRA for the three 1-litre *P. furiosus* cultures.

One 15-litre Culture

Following the successful tests on the 1-litre cultures, it was necessary to scale up the quantity of amylase for further heat stability tests. University of Georgia prepared a 15-litre culture using the same basic medium as with the 1-litre cultures, with the methods of preparation exactly the same, except that the resazurin indicator was not added. A 40 mL culture grown for 12 hours was used as an inoculum for a 500 mL culture, which in turn was grown for 12 hours and used to inoculate 15-litres of medium contained in a 20-litre fermentor. All incubations were at 98°C.

Once the 15-litre culture reached approximately 2×10^8 cells/mL, the extracellular fraction was obtained by centrifugation at $10,000 \times g$ for 10 minutes. The supernatant was concentrated from 15-litres to 2-litres at 4°C using a hollow fibre membrane system with a 10

kDa filter. This took approximately 3 hours, during which time the supernatant became cloudy. A total of 1,020 g of ammonium sulphate was added slowly to the supernatant over a period of 1 hour, and stirring was continued at 4°C for a further 16 hours.

Samples (2 mL) of the supernatant and from the steps prior to ammonium sulphate addition were retained for activity assays. The suspension was then centrifuged at 10,000 x g for 10 minutes and the precipitate was collected. Resazurin was not added and consequently the precipitate was brownish in colour. The precipitate was sent by express mail to Campden & Chorleywood Food Research Association Group Services packed in dry ice.

Method used by U. Georgia for amylase analyses

Amylase activity was measured using Remazolbrilliant Blue. Starch azure (0.3 % wt/vol; Sigma, St Louis, Mo.) was washed with 50 mM EPPS (pH 7.5) containing 40 mM NaCl. The insoluble material was recovered by centrifugation at 10,000 x g for 15 minutes and resuspended in the same buffer to the same concentration. This wash step was repeated three times to remove any unbound Remazolbrilliant Blue. To measure activity, 100 µL samples were incubated at 80°C with 900 µL of the starch suspension, with vortexing every 5 minutes. The amount of product release was measured at 595 nm, where 1 unit is equivalent to a change of absorbance of 1.0/h.

As shown in Table 1, the 15-litre culture contained 2.3 units of amylase activity per mL of culture, whereas the 1-litre cultures yielded almost three-times as much (6.4 units/mL). Most of the amylase activity in both cultures was in the extracellular fractions, as activity was not lost to any extent when the whole cells were removed. Similarly, when the 15-litre extracellular fraction was concentrated by filtration, no amylase activity was detected in the flow-through, indicating that all of the amylase was retained by the 10 kDa filter. However, there was a significant decrease in the total activity after the concentration procedure with a 21% recovery (6,520 units from 30,225 units total). The reasons for this are not known. It is possible that activity could be recovered if the sample is diluted, perhaps in the presence of metal ions such as calcium or magnesium.

Table 1: Comparison of amylase production

Fraction	Units/mL	Volume (mL)	Total units
1-litre culture (with cells)	6.475	1,000	6,475
1-litre culture supernatant (without cells)	6.210	1,000	6,210
15-litre culture (with cells)	2.355	15,000	35,325
15-litre culture supernatant (without cells)	2.015	15,000	30,225
10 kDa flow-through (15-litre)	0	13,000	0
10 kDa concentrate (15-litre)	3.260	2,000	6,520
Ammonium sulphate (15-litre)	3.105	2,000	6,210